

Handling Manual

for

1.5 mm System LIF Sealed Connector 18P

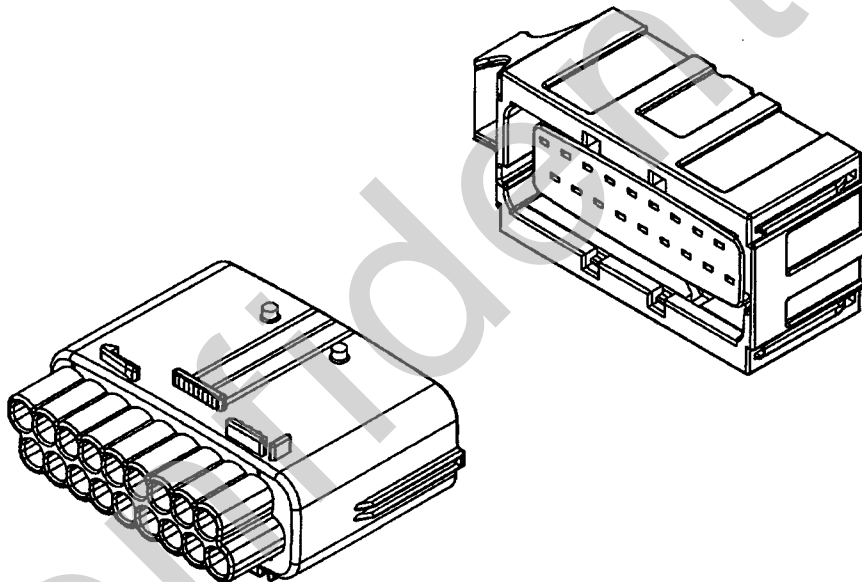

This document has in its content product manufacturing and handling specification, which have to be fulfilled in order to meet the quality and performance requirements of the final product specified in the product specification. The achieved values meeting the mentioned requirements are valid after release of this document as a product specification.

Prepared M. Le	Sign <i>ce</i>	Checked	Sign	Approved <i>H. Leutsch</i>	Sign <i>duf</i>	YAZAKI	
Date 12.05.03		Date		Date <i>03/05/15</i>		Doc.No. YPES-15-584E	Rev. 1
<small>Any exploitation of this document, which is not permitted by Copyright, in particular to copy this document to pass it to third parties, to adapt it or to store it on microfilm or in systems of electronic data processing is forbidden without express authorization. Offenders are liable to damages. The communication of the content of this document to third parties of this document is forbidden by contract.</small>							

Table Of Contents

1. Product outline	3
2. Part Description And Function.....	4
2.1 Male Connector	4
2.2 Female Connector.....	5
2.3 Male Terminal	7
2.4 Female Terminal	7
3. Part Storage, Transportation And Handling Precautions.....	8
3.1 Inspection At Receiving.....	8
3.2 Terminals	8
3.2.1 Transportation And Storage.....	8
3.3 Housing, housing seal, lever, wire seal and front holder	10
4. Installation Instruction	11
4.1 Male Connector	11
4.1.1 Male Terminal Installation.....	11
4.1.2 Dummy Plugs	13
4.2 Female Connector.....	14
4.2.1 Female Terminal Installation.....	14
4.2.2 Dummy Plugs	16
5. Removal Instructions	17
5.1 Front Holder Removal	17
5.1.1 Male Front Holder Disengagement.....	17
5.1.2 Female Front Holder Disengagement	18
5.2 Terminal Removal.....	19
5.2.1 Male Terminal.....	19
5.2.2 Female Terminal	20
5.3 Terminal Removal Tool Shape	22
6. Connector Mating And Unmating Instruction	23
6.1 Connector Mating.....	23
6.2 Connector Unmating.....	28
7. Precautions During Wiring Harness assembly	29
7.1 Wiring Harness Assembly.....	29
7.2 Taping	29
7.3 Inspection	29
7.4 Notice Packing Of Wiring Harness	29
8. Component List.....	29

1. Product outline

This is an 18 pole sealed connector, which is designed for usage with the gearbox in cars. For the electrical connection between male and female a 1.5 mm Yazaki YES terminal system is used.

The female connector has a lever to reduce the mating force.

Delivery condition:

- a) Assembled male connector with front holder in preset position.
- b) Assembled female connector with housing seal, front holder in pre-set position, and lever in set position

For further details of the parts, please see Yazaki reference drawing 7282-6493-30:R and 7283-6493-30:R.

Confidential

Title	Doc.No.	Rev.
1.5 mm System Sealed Connector Female 18P	YPES-15-584E	0
Any exploitation of this document, which is not permitted by Copyright, in particular to copy this document to pass it to third parties, to adapt it or to store it on microfilm or in systems of electronic data processing is forbidden without express authorization. Offenders are liable to damages. The communication of the content of this document to third parties of this document is forbidden by contract.		

2. Part Description And Function

2.1 Male Connector

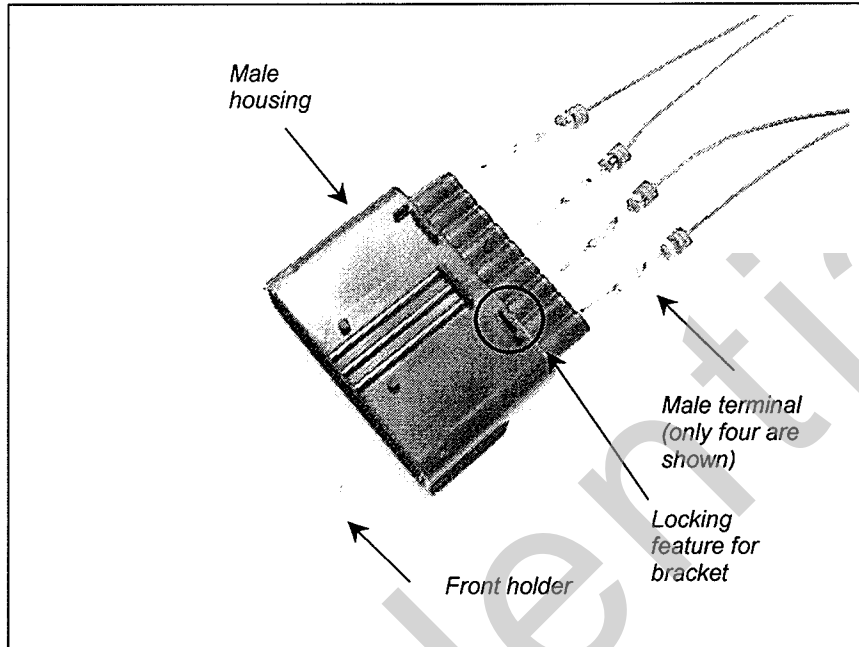

Figure 1:

Part Description	Function
Locking feature for bracket	Locking with the bracket
Front holder	Checks if all terminals are fully inserted
Housing lance	Locking (retention) of male terminal
Post	For the mating procedure with female connector

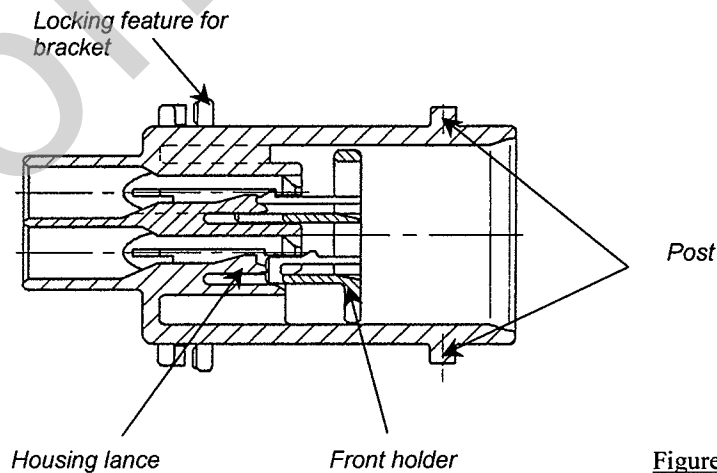

Figure 2:

Title 1.5 mm System Sealed Connector Female 18P	Doc.No. YPES-15-584E	Rev. 0
Any exploitation of this document, which is not permitted by Copyright, in particular to copy this document to pass it to third parties, to adapt it or to store it on microfilm or in systems of electronic data processing is forbidden without express authorization. Offenders are liable to damages. The communication of the content of this document to third parties of this document is forbidden by contract.		

2.2 Female Connector

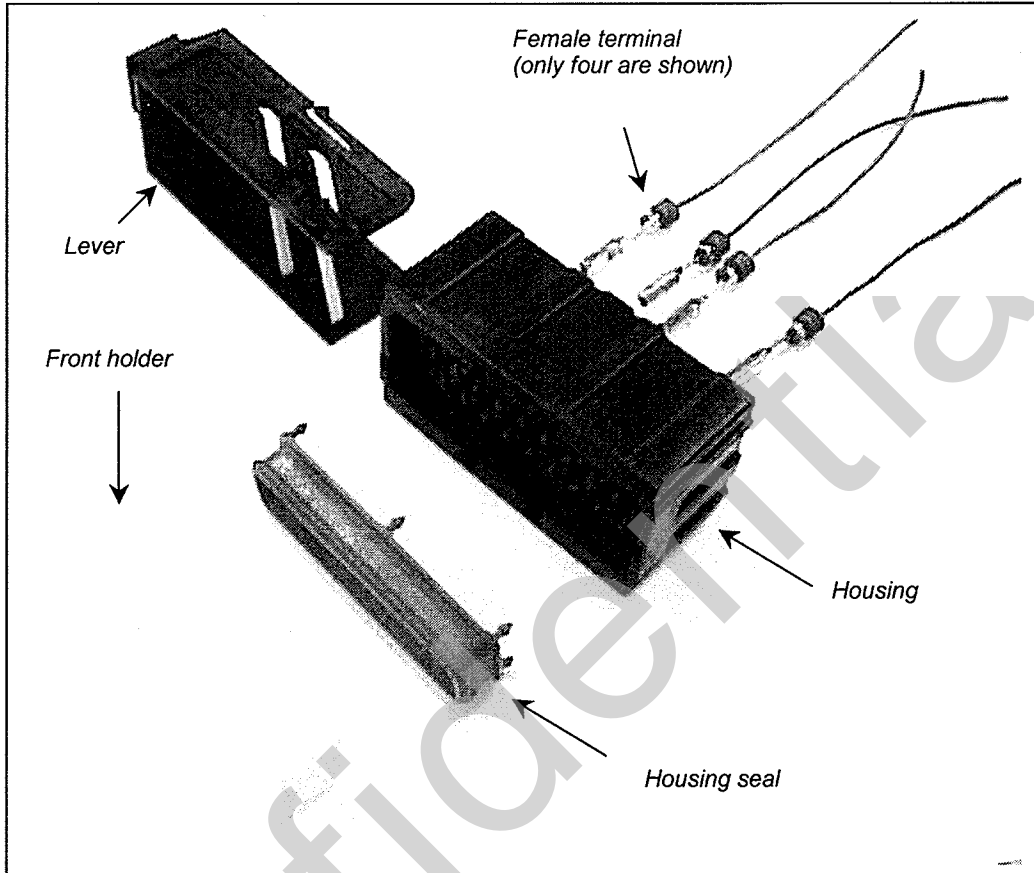
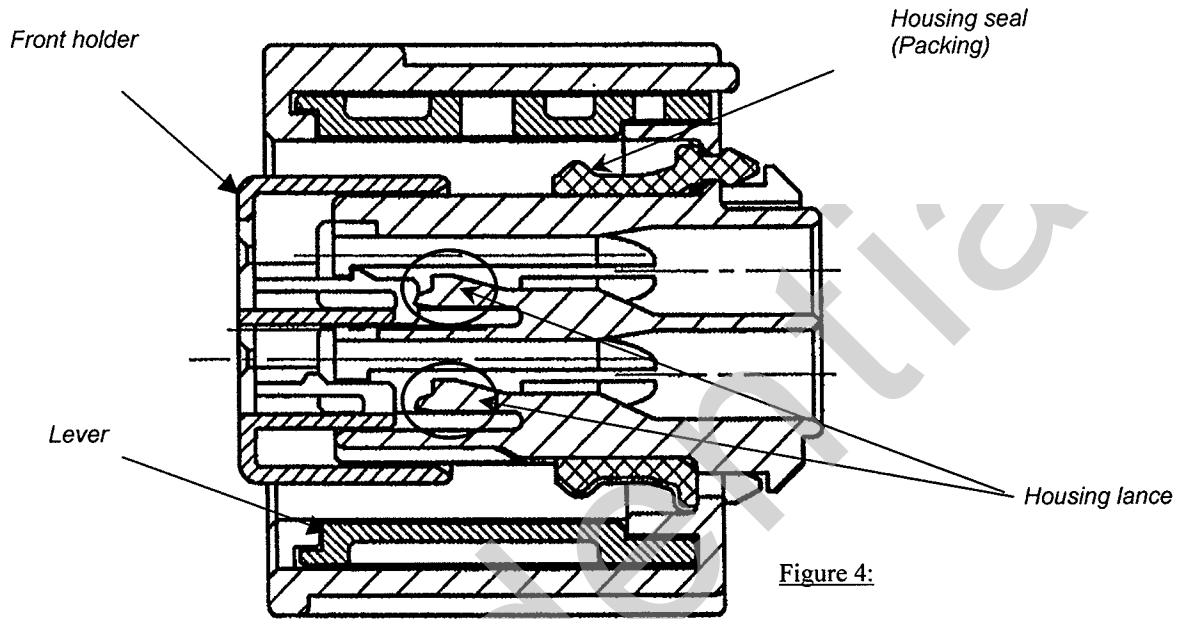

Figure 3:

Title 1.5 mm System Sealed Connector Female 18P	Doc.No. YPES-15-584E	Rev. 0
Any exploitation of this document, which is not permitted by Copyright, in particular to copy this document to pass it to third parties, to adapt it or to store it on microfilm or in systems of electronic data processing is forbidden without express authorization. Offenders are liable to damages. The communication of the content of this document to third parties of this document is forbidden by contract.		



Part Description	Function
Front holder	Checks if all terminals are fully inserted
Housing lance	Locking/retention of female terminal
Lever	Reduce connector mating force
Housing Seal (Packing)	Provide sealing between female and male housing. It protects connector from water ingress.

Title	Doc.No.	Rev.
1.5 mm System Sealed Connector Female 18P	YPES-15-584E	0
Any exploitation of this document, which is not permitted by Copyright, in particular to copy this document to pass it to third parties, to adapt it or to store it on microfilm or in systems of electronic data processing is forbidden without express authorization. Offenders are liable to damages. The communication of the content of this document to third parties of this document is forbidden by contract.		

2.3 Male Terminal

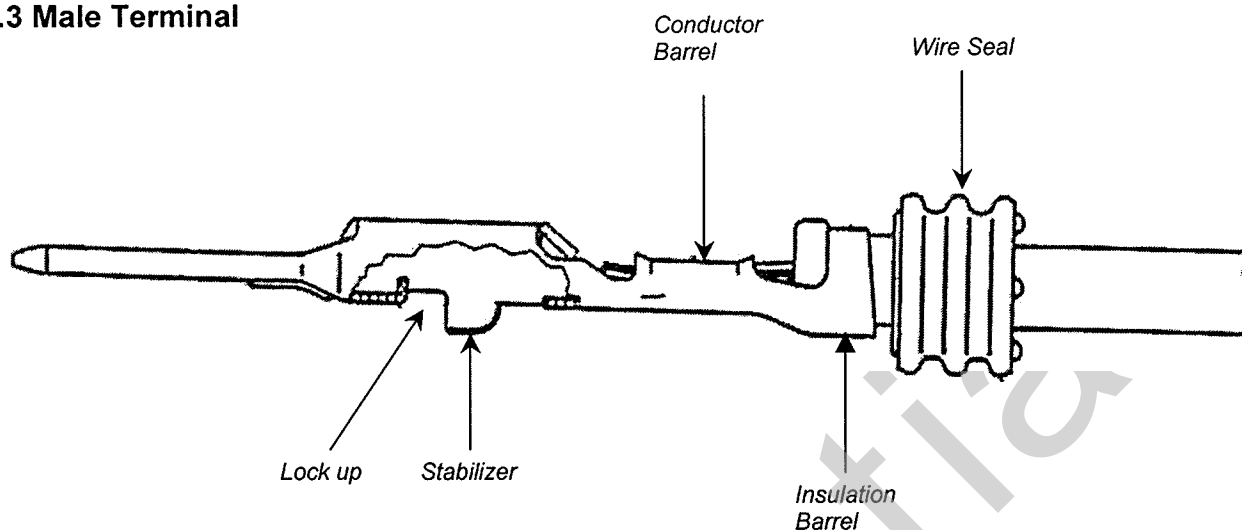

Figure 5:

Part Description	Function
Conductor barrel	Conductor crimping
Insulation barrel	Insulation crimping
Stabilizer	Prevents terminal improper insertion
Wire seal	Provides sealing between wire and housing
Lock up	Provides surface for lock-up with terminal cavity lock arm

2.4 Female Terminal

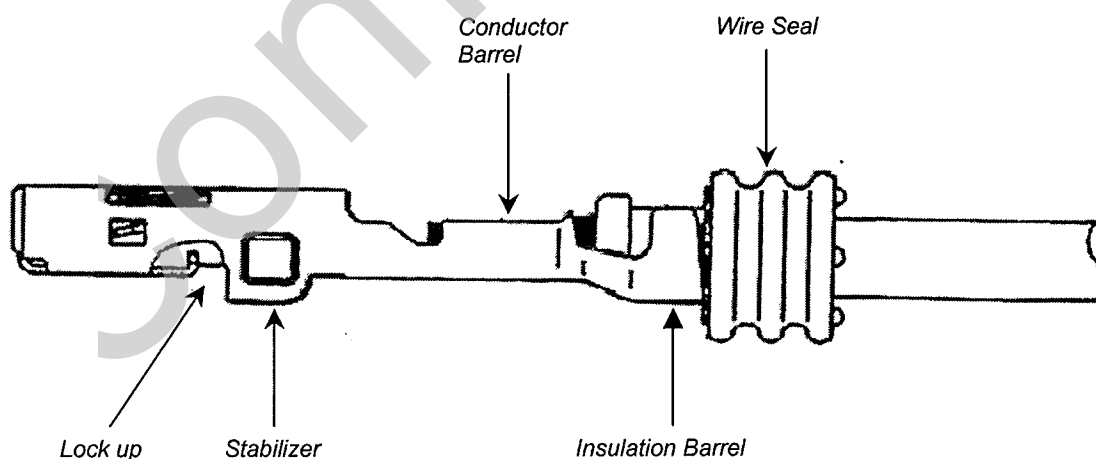

Figure 6:

For part description and function see male terminal table above.

Title	Doc.No.	Rev.
1.5 mm System Sealed Connector Female 18P	YPES-15-584E	0
Any exploitation of this document, which is not permitted by Copyright, in particular to copy this document to pass it to third parties, to adapt it or to store it on microfilm or in systems of electronic data processing is forbidden without express authorization. Offenders are liable to damages. The communication of the content of this document to third parties of this document is forbidden by contract.		

3. Part Storage, Transportation And Handling Precautions

Parts must be free of deformation, damage, etc. during storage and transportation.

3.1 Inspection At Receiving

Inspection in accordance with YAZAKI inspection standard is performed on the product prior to shipping. It is also recommended that each customer conduct the inspection based on the reference drawing for the following items:

- Foreign object or inappropriate product
- Chipping, crack or deformations (sink mark, drooping short shot, etc.)
- Burr, discoloration, rust, unclean parts or peeling
- Inadvertent disengagement of front holder, or missing front holder.
- Inadvertent disengagement of housing seal, or missing housing seal

3.2 Terminals

3.2.1 Transportation And Storage

Recommended storage and transportation of terminal reels are shown below.

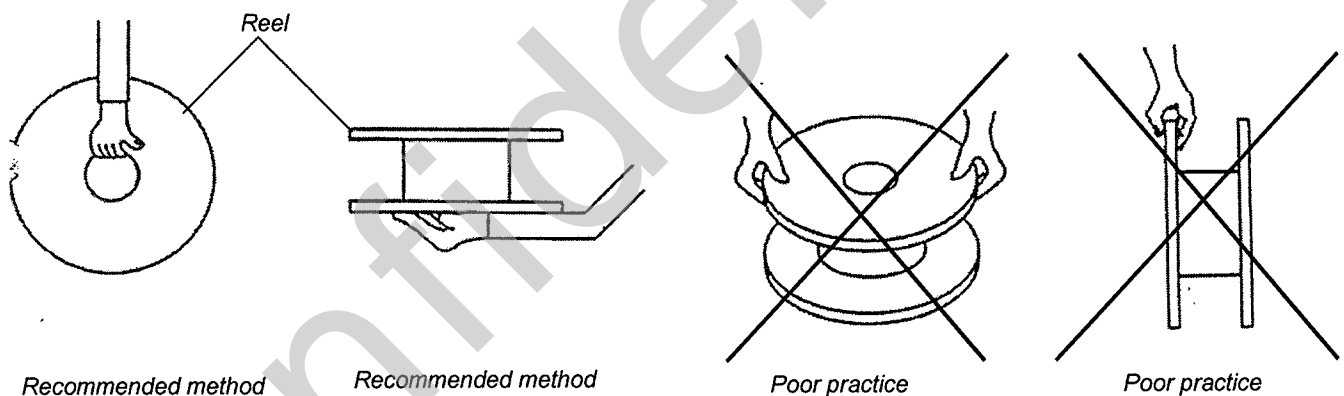

Figure 7:

Title	Doc.No.	Rev.
1.5 mm System Sealed Connector Female 18P	YPES-15-584E	0
Any exploitation of this document, which is not permitted by Copyright, in particular to copy this document to pass it to third parties, to adapt it or to store it on microfilm or in systems of electronic data processing is forbidden without express authorization. Offenders are liable to damages. The communication of the content of this document to third parties of this document is forbidden by contract.		

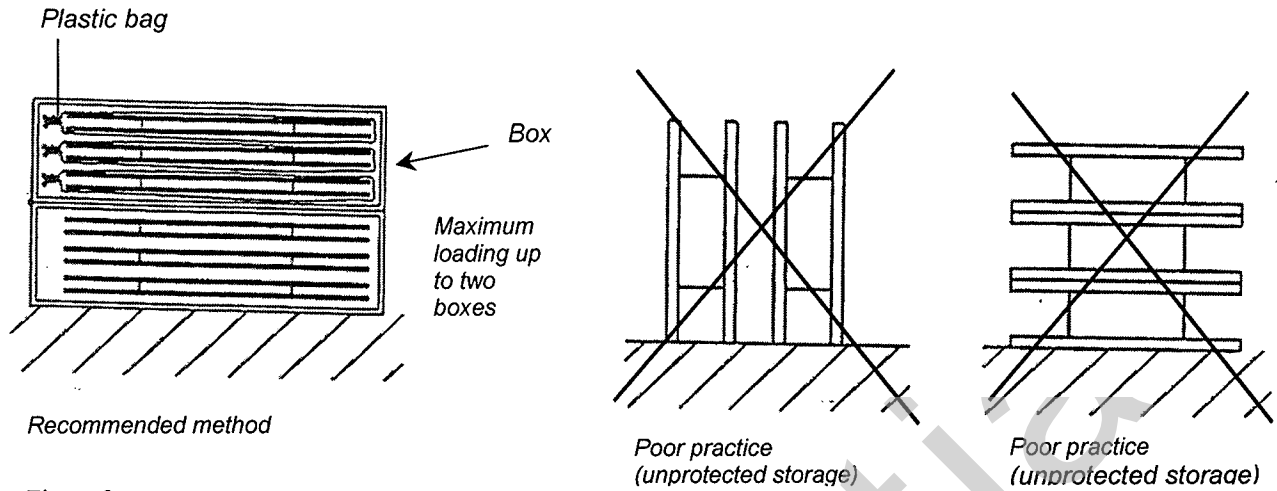

Figure 8:

- Terminals should be stored in the box or plastic bag in which they were shipped.
- Terminal should be stored indoors, away from direct sunlight.
- Terminal should be stored in an area where excess temperature and/or humidity cannot occur.
- Parts must not be stored in an unprotected condition (i.e. parts should be protected from water, oil, dust, etc.).
- Care should be taken to avoid any harsh impacts by dropping and on the part containers during transportation.
- Partial reel of terminals should have the carrier strip secured to prevent reel unwinding or terminal entanglement. Recommended method is shown below.
- Maximum stack height is 2 boxes.

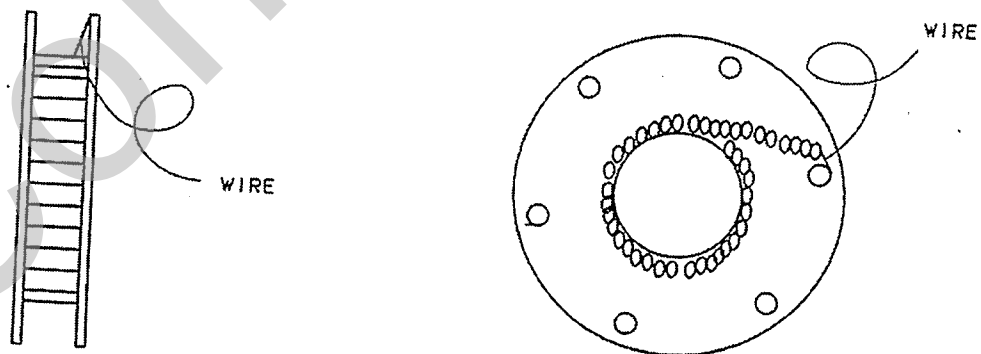

Figure 9:

Title 1.5 mm System Sealed Connector Female 18P	Doc.No. YPES-15-584E	Rev. 0
Any exploitation of this document, which is not permitted by Copyright, in particular to copy this document to pass it to third parties, to adapt it or to store it on microfilm or in systems of electronic data processing is forbidden without express authorization. Offenders are liable to damages. The communication of the content of this document to third parties of this document is forbidden by contract.		

3.3 Housing, housing seal, lever, wire seal and front holder

Please pay attention to the following recommendation for storage, transportation and handling in order to avoid deformation or damage:

- Parts should be stored in the carton box in which they were shipped.
- Parts should be protected specifically from water, oil and dust.
- Do not store in unprotected condition.
- Do not pile up.
- Parts should be stored indoors, away from direct sunlight.
- Parts should be stored in an area where excess temperature and/or humidity cannot occur.
(Room temperature: 5-35°C, humidity: 45-85% RH)
- Avoid any outside force during storage.
- Care should be taken to avoid any harsh impact by dropping.

Title 1.5 mm System Sealed Connector Female 18P	Doc.No. YPES-15-584E	Rev. 0
Any exploitation of this document, which is not permitted by Copyright, in particular to copy this document to pass it to third parties, to adapt it or to store it on microfilm or in systems of electronic data processing is forbidden without express authorization. Offenders are liable to damages. The communication of the content of this document to third parties of this document is forbidden by contract.		

4. Installation Instruction

4.1 Male Connector

4.1.1 Male Terminal Installation

- a) First assure that the orientation of the male terminal is correct and that the front holder is in pre-set position (figure 10). If this is not the case, please read section 5.1.1 to move the front holder from set to pre-set position.

Note: It is not possible to insert a terminal if the front holder is in the set position (figure 11).

*Front holder pre-set position
(delivery condition)*

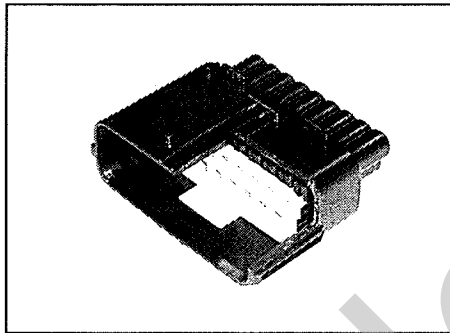

Figure 10:

Front holder in set position

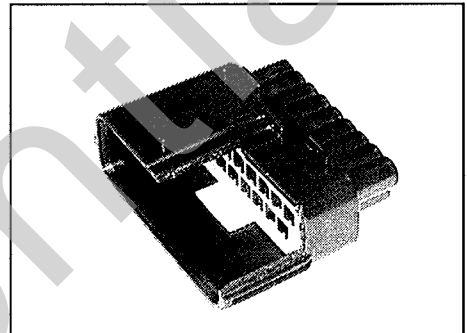

Figure 11:

Confirm no deformation or damage on terminals. Replace any deformed or damaged terminals with new ones.

- b) Push the terminal into the appropriate cavity housing of the male housing. Insert the terminal until an audible “click” sound is heard. After complete terminal insertion, pull lightly on the wire to confirm full lock-up.

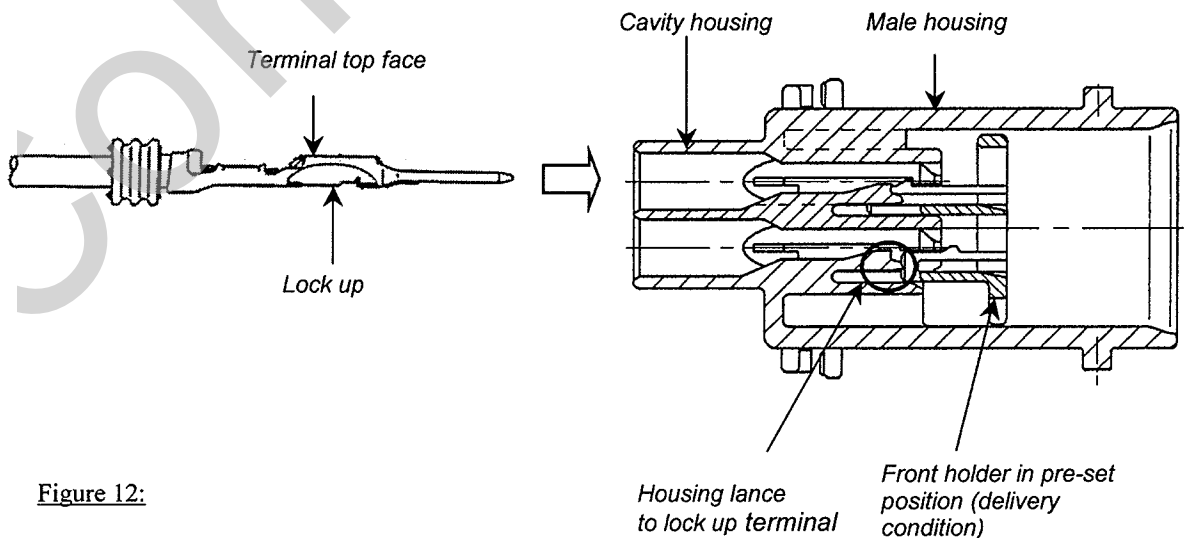

Figure 12:

<p>Title 1.5 mm System Sealed Connector Female 18P</p>	<p>Doc.No. YPES-15-584E</p>	<p>Rev. 0</p>
<p><small>Any exploitation of this document, which is not permitted by Copyright, in particular to copy this document to pass it to third parties, to adapt it or to store it on microfilm or in systems of electronic data processing is forbidden without express authorization. Offenders are liable to damages. The communication of the content of this document to third parties of this document is forbidden by contract.</small></p>		

c) Repeat step a) and b) until all terminals are inserted (see figure 13).

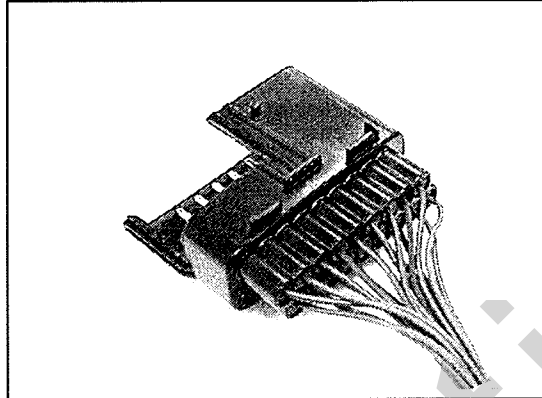

Figure 13:

d) After installation of all applicable terminals, the front holder must be moved to the set position. To do this just push on the front holder.

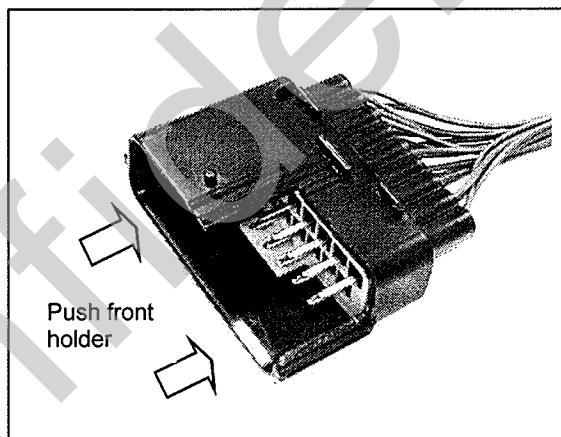

Figure 14:

Engagement of the front holder to the set position cannot be completed if one of the following conditions exists:

- One or more terminals are not fully inserted in the cavity.
- One or more terminals are inserted with the wrong orientation.

After the conditions noted above are corrected, the front holder can be fully installed. Failure to correct these conditions prior to full front holder installation could result in damage to either the front holder or the housing.

Title	Doc.No.	Rev.
1.5 mm System Sealed Connector Female 18P	YPES-15-584E	0
Any exploitation of this document, which is not permitted by Copyright, in particular to copy this document to pass it to third parties, to adapt it or to store it on microfilm or in systems of electronic data processing is forbidden without express authorization. Offenders are liable to damages. The communication of the content of this document to third parties of this document is forbidden by contract.		

Figure 15 shows a different connector as an example, what can happen if a terminal is only half inserted. High pressure to the front holder in this case can damage the pacer and/or housing lance.

Therefore, care should be taken to avoid the possibility of partial front holder installation.

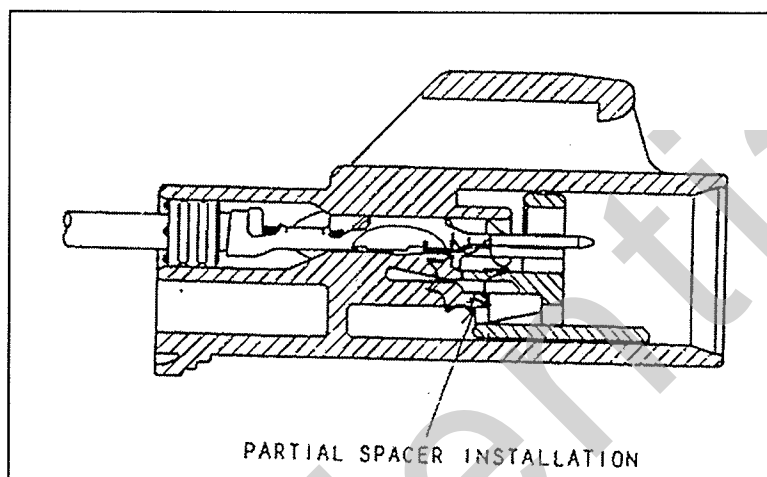

Figure 15:

4.1.2 Dummy Plugs

Please use a dummy plug if a housing cavity is not used. The Yazaki part number is 7158-3032-60. The following figures show how to insert a dummy plug into the cavity. There is no orientation, which has to be considered.

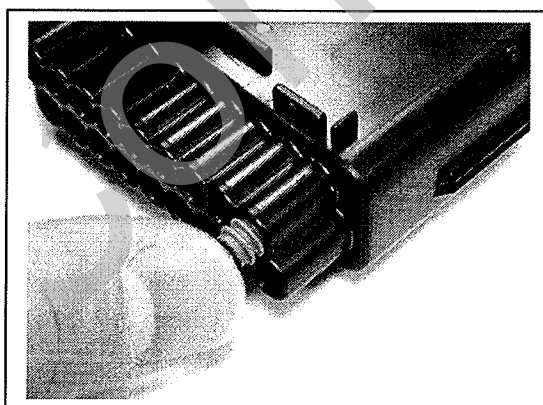

Figure 16:

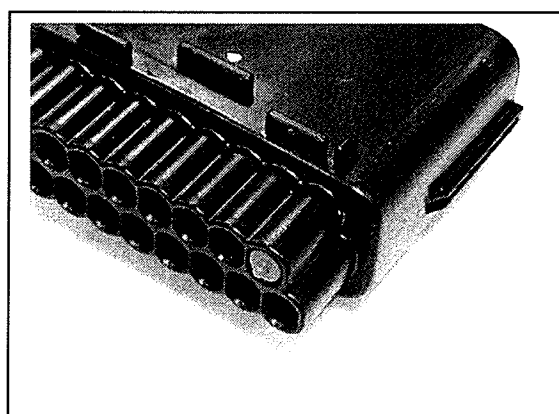

Figure 17:

Title 1.5 mm System Sealed Connector Female 18P	Doc.No. YPES-15-584E	Rev. 0
Any exploitation of this document, which is not permitted by Copyright, in particular to copy this document to pass it to third parties, to adapt it or to store it on microfilm or in systems of electronic data processing is forbidden without express authorization. Offenders are liable to damages. The communication of the content of this document to third parties of this document is forbidden by contract.		

4.2 Female Connector

4.2.1 Female Terminal Installation

- a) First assure that the orientation of the female terminal is correct and that the front holder is in pre-set position (figure 18). If this is not the case, please read section 5.1.2 to move the front holder from set to pre-set position.

Note: It is not possible to insert a terminal if the front holder is in the set position.

*Front holder pre-set position
(Delivery condition)*

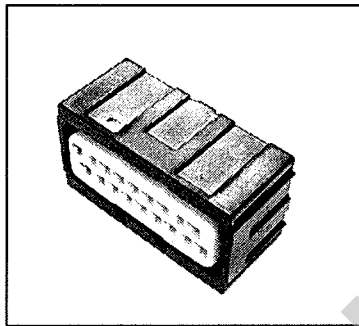

Figure 18:

Front holder in set position

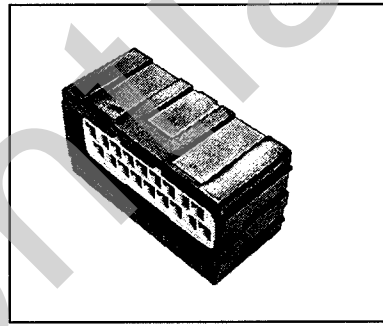

Figure 19:

Confirm no deformation or damage on terminals. Replace any deformed or damaged terminals with new ones.

- b) Push the terminal into the appropriate cavity of the female housing. Insert the terminal until an audible “click” sound is heard. After complete terminal insertion, pull lightly on the wire to confirm full lock-up.

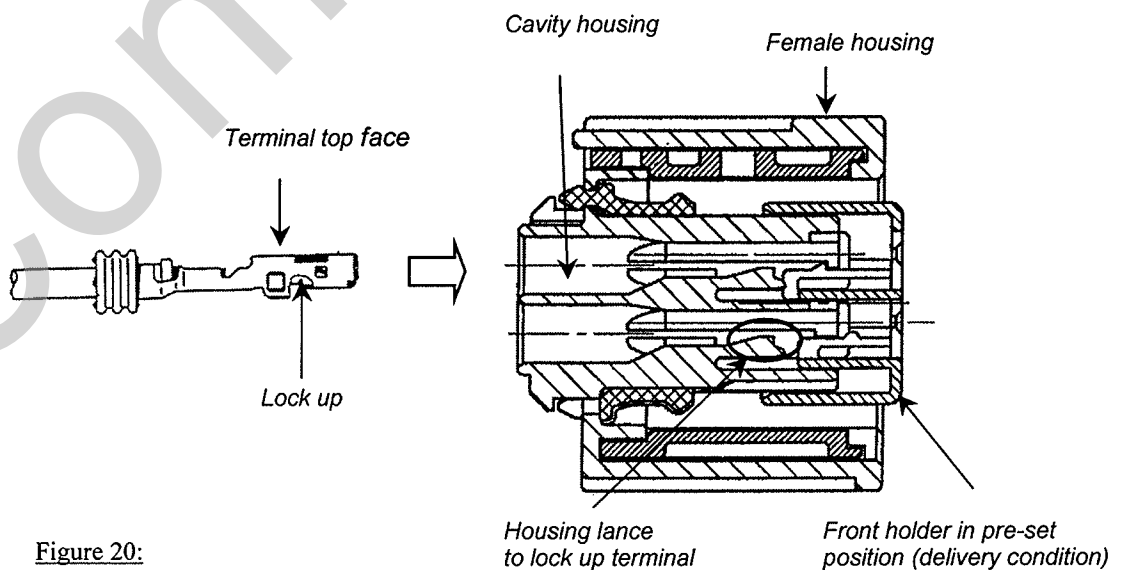

Figure 20:

<p>Title 1.5 mm System Sealed Connector Female 18P</p>	<p>Doc.No. YPES-15-584E</p>	<p>Rev. 0</p>
<p><small>Any exploitation of this document, which is not permitted by Copyright, in particular to copy this document to pass it to third parties, to adapt it or to store it on microfilm or in systems of electronic data processing is forbidden without express authorization. Offenders are liable to damages. The communication of the content of this document to third parties of this document is forbidden by contract.</small></p>		

c) Repeats step a) and b) until all terminals are inserted (see figure 21).

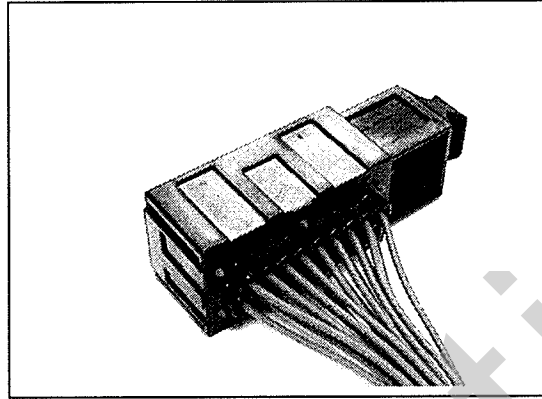

Figure 21:

d) After installation of all applicable terminals, the front holder must be moved to the set position. To do this just push on the front holder.

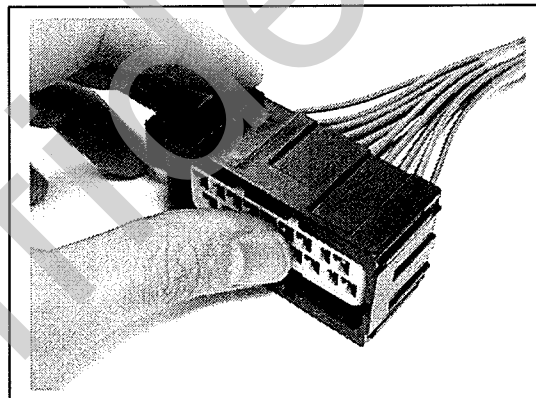

Figure 22:

Engagement of the front holder to the set position cannot be completed if one of the following conditions exists:

- One ore more terminals are not fully inserted in the cavity.
- One ore more terminals are inserted with the wrong orientation.

If a terminal is only half inserted and high pressure to the front holder is applied, the front holder and/or housing lance can be damaged.

After the conditions noted above are corrected, the front holder can be fully installed. Failure to correct these conditions prior to full front holder installation could result in damage to either the front holder or the housing.

Title 1.5 mm System Sealed Connector Female 18P	Doc.No. YPES-15-584E	Rev. 0
Any exploitation of this document, which is not permitted by Copyright, in particular to copy this document to pass it to third parties, to adapt it or to store it on microfilm or in systems of electronic data processing is forbidden without express authorization. Offenders are liable to damages. The communication of the content of this document to third parties of this document is forbidden by contract.		

4.2.2 Dummy Plugs

Please use a dummy plug if a housing cavity is not used. The Yazaki part number is 7158-3032-60.

The following figures show how to insert a dummy plug into the cavity.

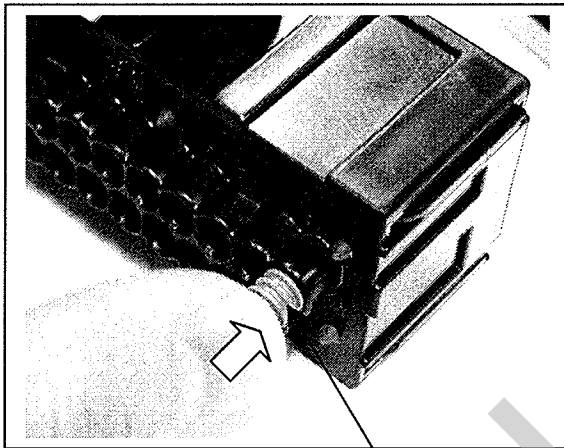

Figure 23:

Dummy Plug

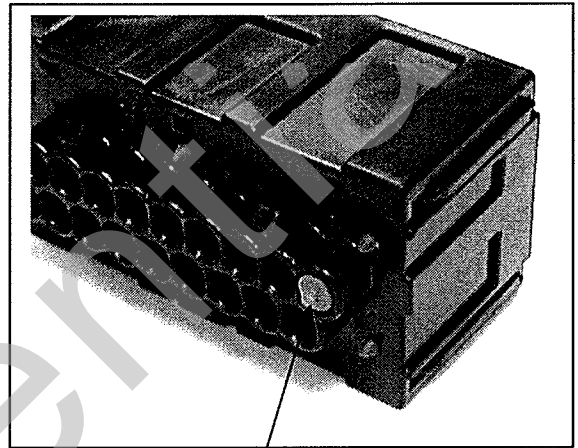

Figure 24:

*Dummy Plug seal
fully inserted*

Title	Doc.No.	Rev.
1.5 mm System Sealed Connector Female 18P	YPES-15-584E	0
Any exploitation of this document, which is not permitted by Copyright, in particular to copy this document to pass it to third parties, to adapt it or to store it on microfilm or in systems of electronic data processing is forbidden without express authorization. Offenders are liable to damages. The communication of the content of this document to third parties of this document is forbidden by contract.		

5. Removal Instructions

The following procedures should be used when removing and/or servicing the terminals from this connector system.

5.1 Front Holder Removal

To remove the front holder of male and female connector, please use the tool shown below.

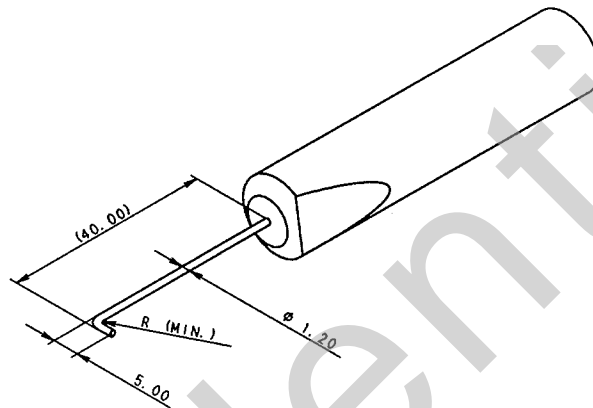

Figure 25:

5.1.1 Male Front Holder Disengagement

Insert the tool into the slot provided as shown in figure 25b. Then pull in the direction of the arrow in figure 26. This procedure will release the front holder for terminal removal, described in section 5.2.1.

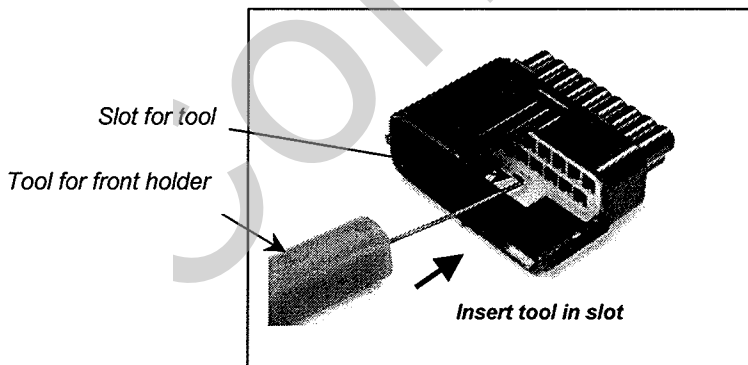

Figure 25b:

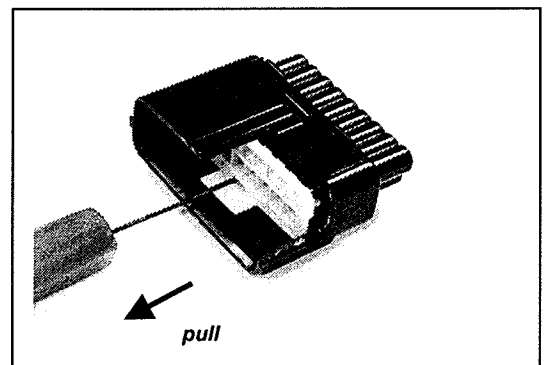

Figure 26:

Title 1.5 mm System Sealed Connector Female 18P	Doc.No. YPES-15-584E	Rev. 0
Any exploitation of this document, which is not permitted by Copyright, in particular to copy this document to pass it to third parties, to adapt it or to store it on microfilm or in systems of electronic data processing is forbidden without express authorization. Offenders are liable to damages. The communication of the content of this document to third parties of this document is forbidden by contract.		

5.1.2 Female Front Holder Disengagement

Insert the tool into the slot provided as shown in the figures below. Then pull in the direction of the arrow in figure 29. This procedure will release the front holder for terminal removal, described in section 5.2.2.

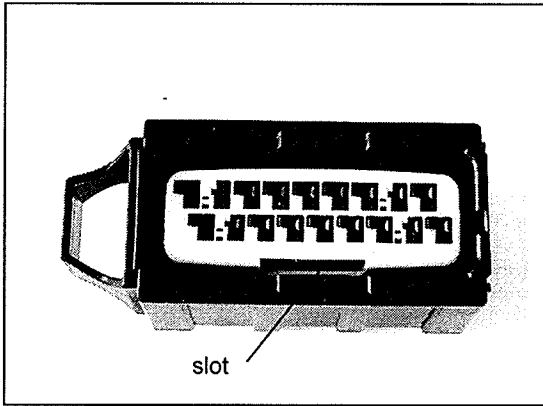

Figure 27:

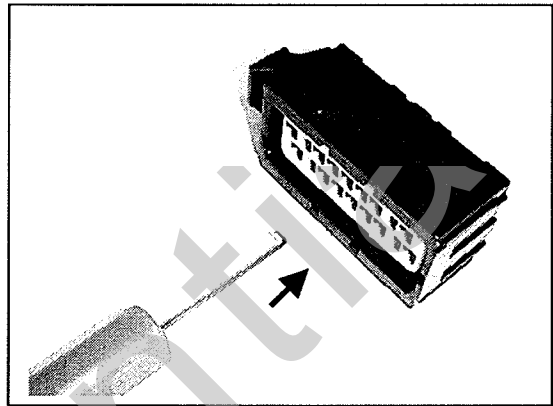

Figure 28a:

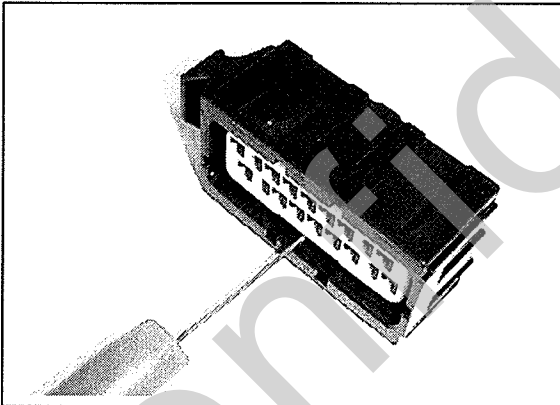

Figure 28b:

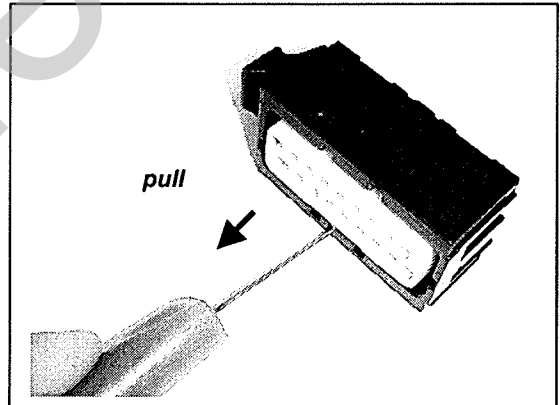

Figure 29:

Title 1.5 mm System Sealed Connector Female 18P	Doc.No. YPES-15-584E	Rev. 0
Any exploitation of this document, which is not permitted by Copyright, in particular to copy this document to pass it to third parties, to adapt it or to store it on microfilm or in systems of electronic data processing is forbidden without express authorization. Offenders are liable to damages. The communication of the content of this document to third parties of this document is forbidden by contract.		

5.2 Terminal Removal

Only trained personnel should perform the terminal removal operation.

Probing of the terminal/cavity by technicians not familiar with the removal process could result in damage to the terminal and/or connector. Use only a removal tool as shown in section 5.3.

5.2.1 Male Terminal

- Push the applicable wire lightly to assure the terminal is fully forward in the terminal cavity.
- Insert the removal tool into the terminal cavity as shown in figures 30 and 31. The tip of the tool must be positioned between the housing lance and the terminal.
- Push the tool forward to deflect the housing lance.
- With the housing lance deflected, pull the wire to remove the terminal from the cavity. If the terminal does not disengage easily from the housing, repeat the steps previously outlined.
- If any damage is visible on the terminal and/or housing the affected component should be replaced. Repairs should not be attempted.

The following figure shows as an example a different male connector, but with the same way to remove the terminal from the housing.

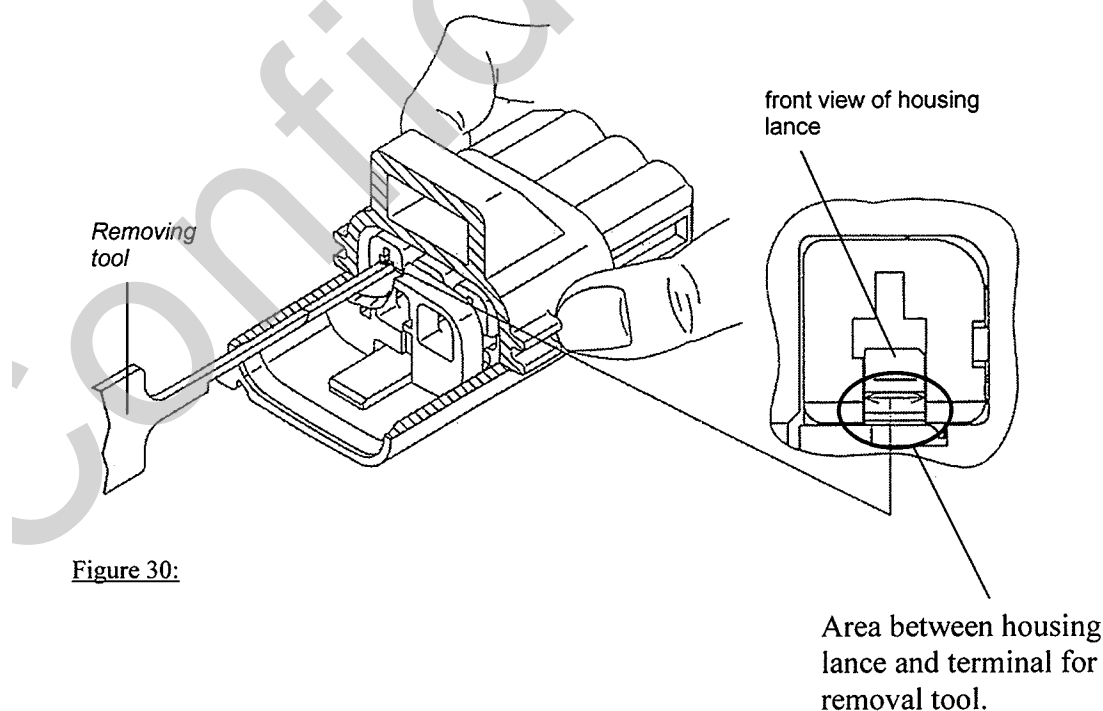

Figure 30:

Title 1.5 mm System Sealed Connector Female 18P	Doc.No. YPES-15-584E	Rev. 0
Any exploitation of this document, which is not permitted by Copyright, in particular to copy this document to pass it to third parties, to adapt it or to store it on microfilm or in systems of electronic data processing is forbidden without express authorization. Offenders are liable to damages. The communication of the content of this document to third parties of this document is forbidden by contract.		

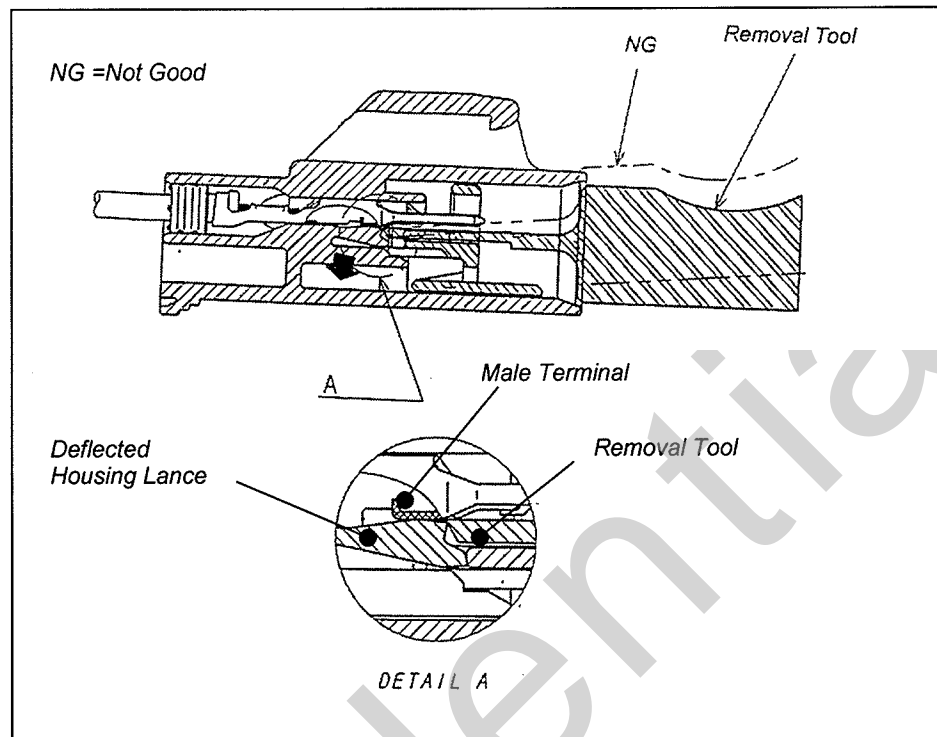

Figure 31:

5.2.2 Female Terminal

- Push the applicable wire lightly to assure the terminal is fully forward in the terminal cavity.
- Insert the removal tool into the terminal cavity as shown in figure 32. The tip of the tool must be positioned between the housing lance and the terminal.
- Push the tool forward to deflect the housing lance.
- With the housing lance deflected, pull the wire to remove the terminal from the cavity. If the terminal does not disengage easily from the housing, repeat the steps previously outlined.
- If any damage is visible on the terminal and/or housing the affected component should be replaced, repairs should not be attempted.

Title 1.5 mm System Sealed Connector Female 18P	Doc.No. YPES-15-584E	Rev. 0
Any exploitation of this document, which is not permitted by Copyright, in particular to copy this document to pass it to third parties, to adapt it or to store it on microfilm or in systems of electronic data processing is forbidden without express authorization. Offenders are liable to damages. The communication of the content of this document to third parties of this document is forbidden by contract.		

The following figure shows as an example a different female connector, but with the same way to remove the terminal from the housing.

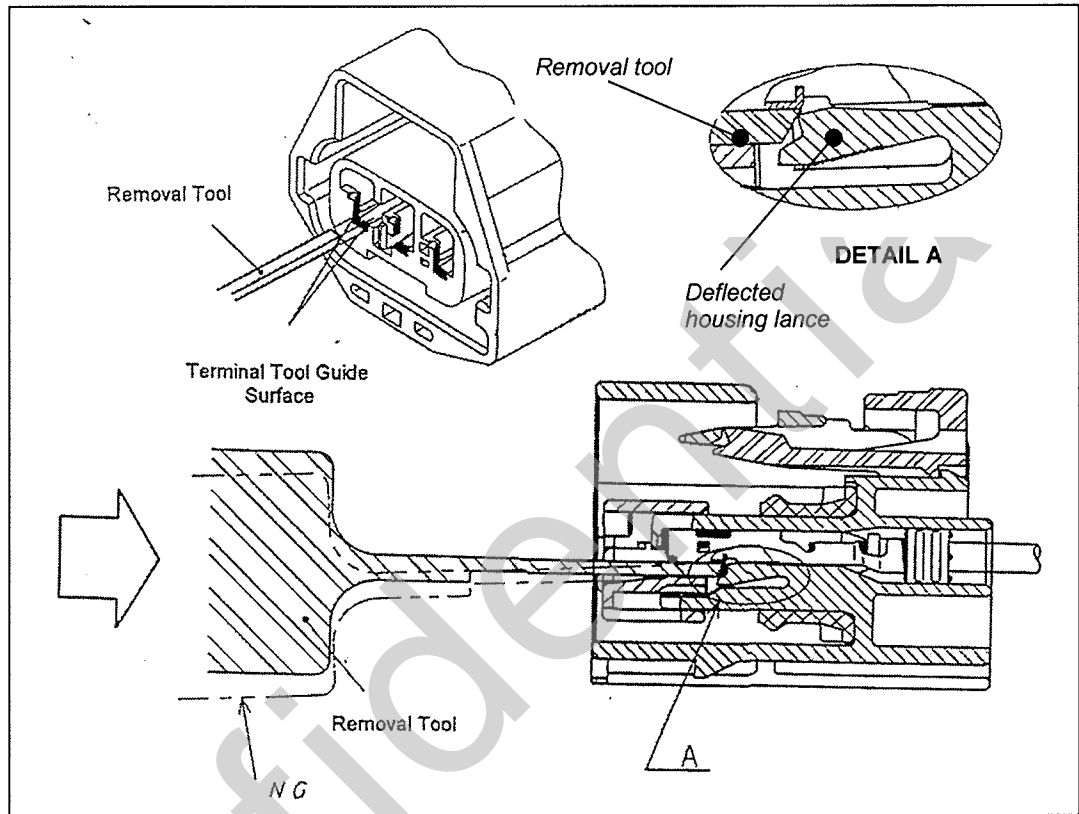

Figure 32:

Title 1.5 mm System Sealed Connector Female 18P	Doc.No. YPES-15-584E	Rev. 0
Any exploitation of this document, which is not permitted by Copyright, in particular to copy this document to pass it to third parties, to adapt it or to store it on microfilm or in systems of electronic data processing is forbidden without express authorization. Offenders are liable to damages. The communication of the content of this document to third parties of this document is forbidden by contract.		

5.3 Terminal Removal Tool Shape

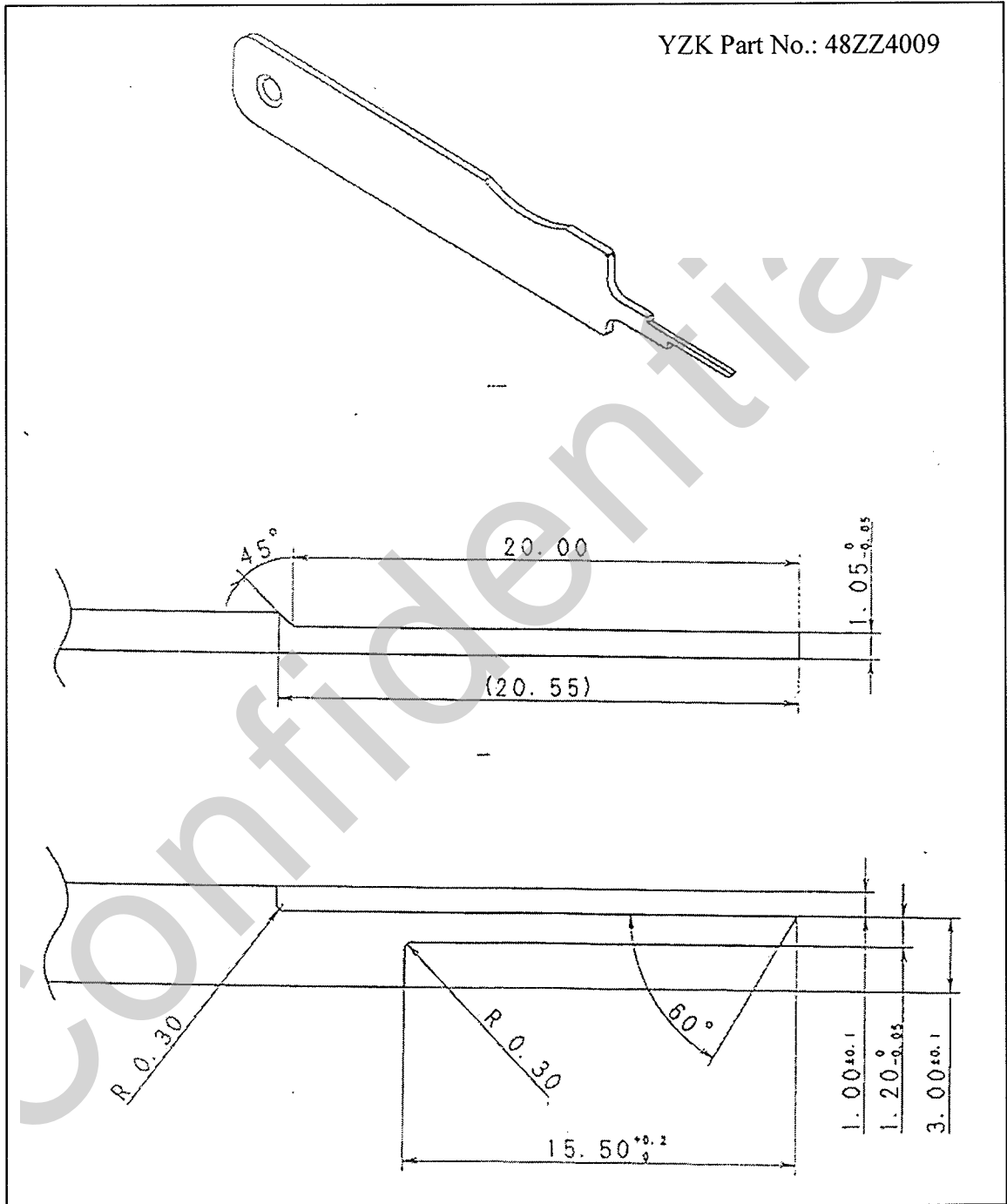

Figure 33:

<p>Title 1.5 mm System Sealed Connector Female 18P</p>	<p>Doc.No. YPES-15-584E</p>	<p>Rev. 0</p>
<p>Any exploitation of this document, which is not permitted by Copyright, in particular to copy this document to pass it to third parties, to adapt it or to store it on microfilm or in systems of electronic data processing is forbidden without express authorization. Offenders are liable to damages. The communication of the content of this document to third parties of this document is forbidden by contract.</p>		

6. Connector Mating And Unmating Instruction

6.1 Connector Mating

This connector system is designed to fix to the bracket as shown in figure 34.

You can find all dimensions of the bracket on the Ford drawing 1X43-9P434-A with the highest revision and latest version.

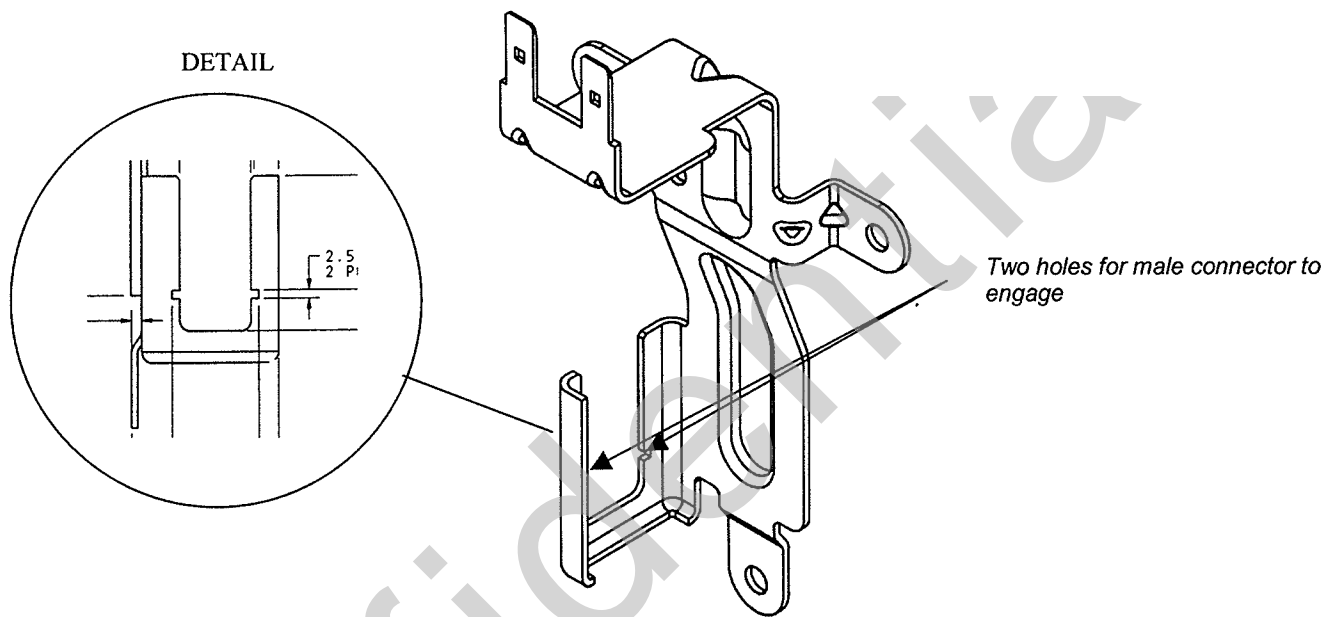

Figure 34:

The following steps are necessary to mate the male and female connector.

- a) Male and female connectors have to be fully equipped with 1.5 mm YESC terminals (with wire seal). The front holder of both housings has to be pushed in set position.

Title	Doc.No.	Rev.
1.5 mm System Sealed Connector Female 18P	YPES-15-584E	0
Any exploitation of this document, which is not permitted by Copyright, in particular to copy this document to pass it to third parties, to adapt it or to store it on microfilm or in systems of electronic data processing is forbidden without express authorization. Offenders are liable to damages. The communication of the content of this document to third parties of this document is forbidden by contract.		

- b) Fix the male connector to the bracket first as shown in these figures. Move the male connector down as the arrow shows in figure 35 until the locking feature is engaged with the holes in the bracket.

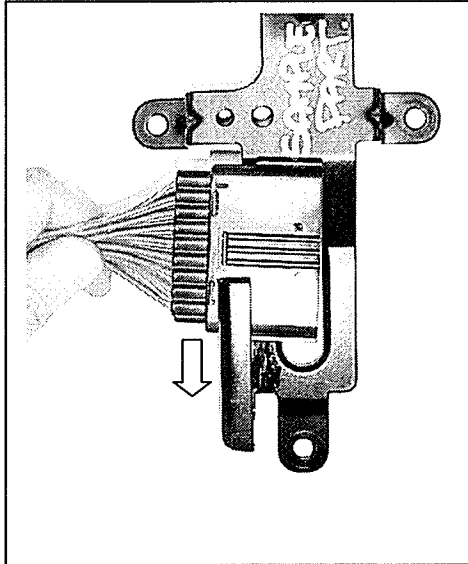

Figure 35:

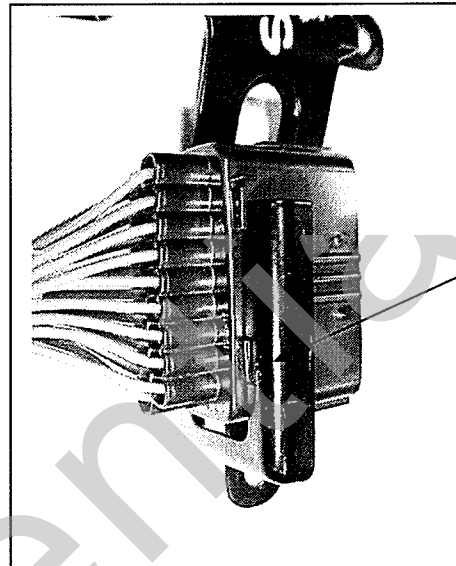

Figure 36:

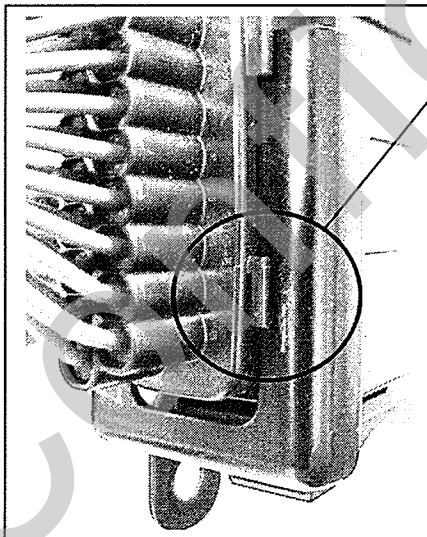

Figure 37:

Title 1.5 mm System Sealed Connector Female 18P	Doc.No. YPES-15-584E	Rev. 0
Any exploitation of this document, which is not permitted by Copyright, in particular to copy this document to pass it to third parties, to adapt it or to store it on microfilm or in systems of electronic data processing is forbidden without express authorization. Offenders are liable to damages. The communication of the content of this document to third parties of this document is forbidden by contract.		

- c) The lever of the female connector has to be in the pre-set position before mating, otherwise it is not possible to mate the parts. Trying to mate the parts with excessive force in this case will cause damage to the housings and/or lever. In addition it can also happen that the connector is only half inserted. Replace any damaged parts with new ones.

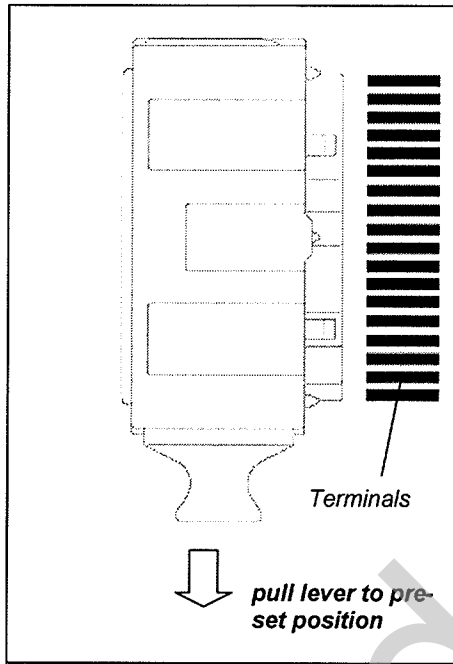

Figure 38a:

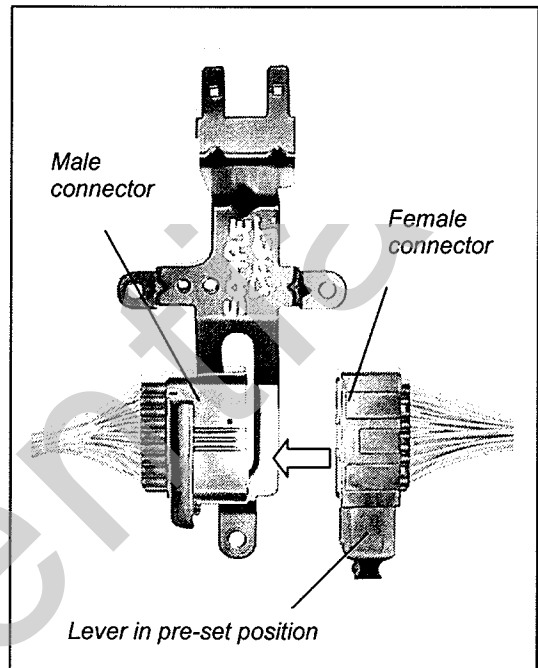

Figure 38b:

- d) Position the female connector so that the four posts of the male connector (figure 39) engage with the female connector's slots as shown in figure 39b and 39c.

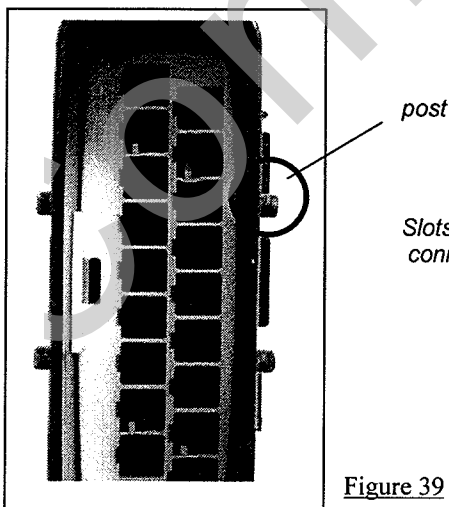

Figure 39

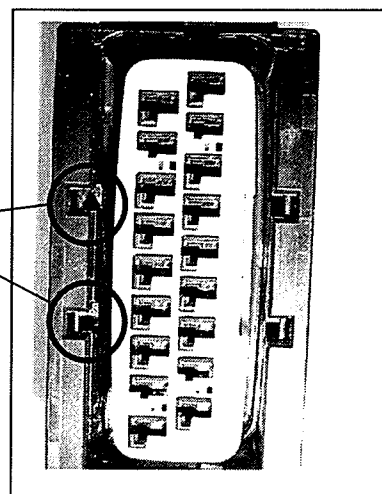

Figure 39b:

Mate the male and female connectors by pushing on the lever as shown in figure 39c.

<p>Title 1.5 mm System Sealed Connector Female 18P</p>	<p>Doc.No. YPES-15-584E</p>	<p>Rev. 0</p>
<p>Any exploitation of this document, which is not permitted by Copyright, in particular to copy this document to pass it to third parties, to adapt it or to store it on microfilm or in systems of electronic data processing is forbidden without express authorization. Offenders are liable to damages. The communication of the content of this document to third parties of this document is forbidden by contract.</p>		

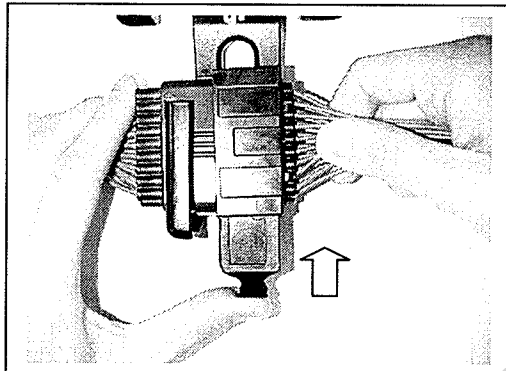

Figure 39c:

- e) The following figure shows the position after the lever is pushed completely in.

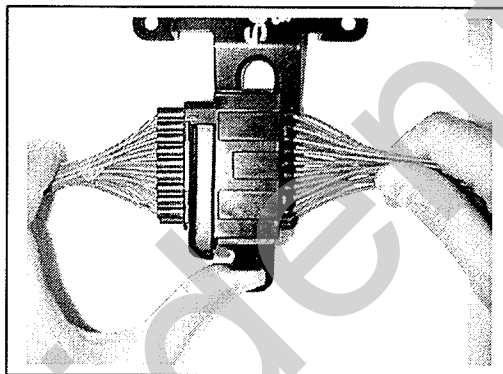

Figure 40:

- f) Finally apply a slight pulling force on male and female part to confirm that the parts are mated correctly.

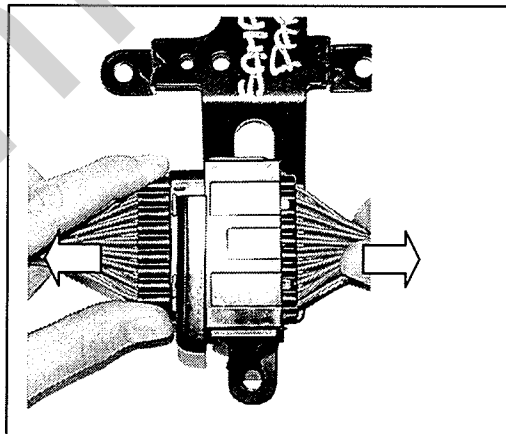
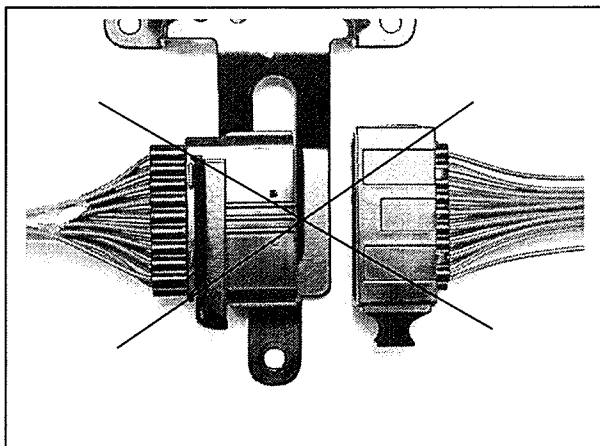

Figure 41:

Title	Doc.No.	Rev.
1.5 mm System Sealed Connector Female 18P	YPES-15-584E	0
Any exploitation of this document, which is not permitted by Copyright, in particular to copy this document to pass it to third parties, to adapt it or to store it on microfilm or in systems of electronic data processing is forbidden without express authorization. Offenders are liable to damages. The communication of the content of this document to third parties of this document is forbidden by contract.		

The following figures will show how it should not be mated!



No !

Lever is not in pre-set position.

Figure 42:

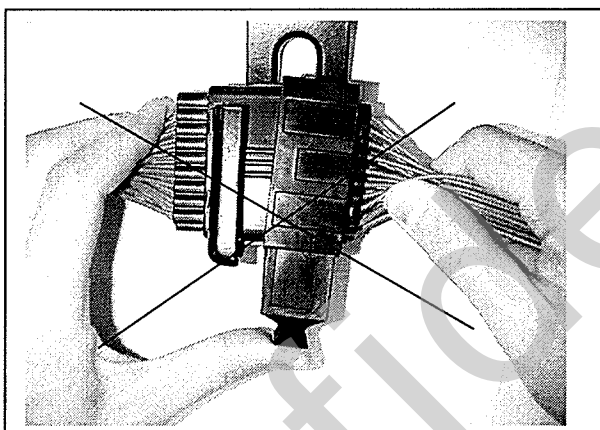

No !

Female connector is twisted.

Figure 43:

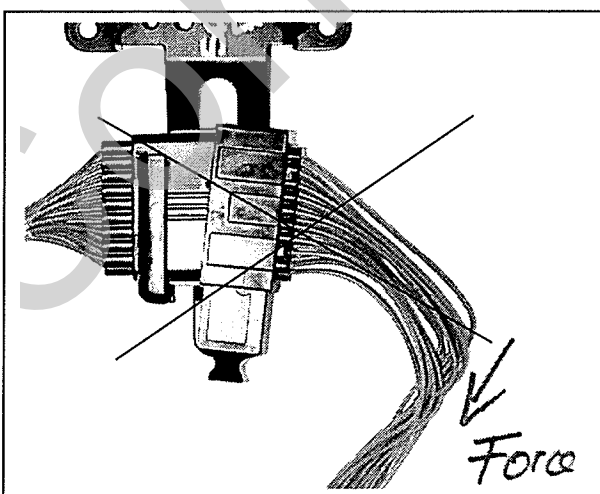

No !

Female connector is twisted due to strong force applying on the wires.

Figure 44:

Title 1.5 mm System Sealed Connector Female 18P	Doc.No. YPES-15-584E	Rev. 0
Any exploitation of this document, which is not permitted by Copyright, in particular to copy this document to pass it to third parties, to adapt it or to store it on microfilm or in systems of electronic data processing is forbidden without express authorization. Offenders are liable to damages. The communication of the content of this document to third parties of this document is forbidden by contract.		

6.2 Connector Unmating

To unmate the connectors, pull on the lever.

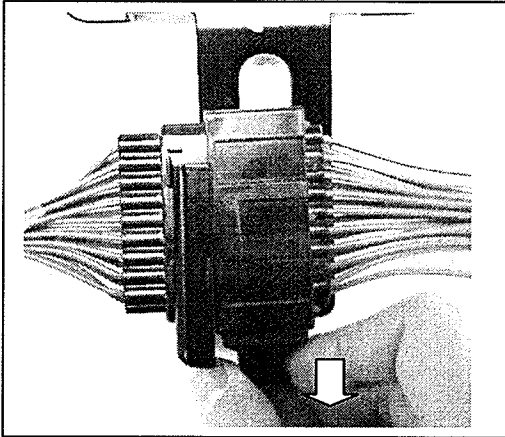

Figure 45:

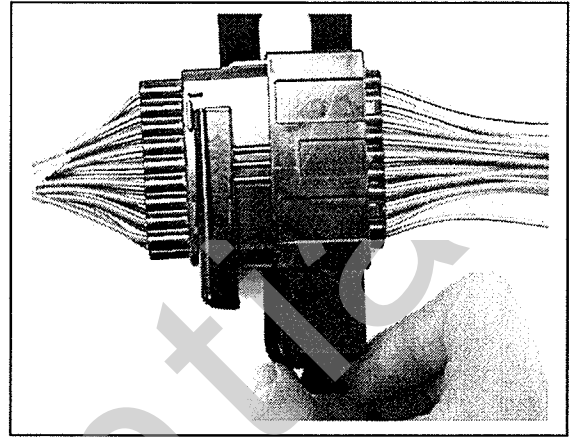

Figure 46:

Confidential

Title 1.5 mm System Sealed Connector Female 18P	Doc.No. YPES-15-584E	Rev. 0
Any exploitation of this document, which is not permitted by Copyright, in particular to copy this document to pass it to third parties, to adapt it or to store it on microfilm or in systems of electronic data processing is forbidden without express authorization. Offenders are liable to damages. The communication of the content of this document to third parties of this document is forbidden by contract.		

7. Precautions During Wiring Harness assembly

7.1 Wiring Harness Assembly

- Do not rework any deformed or damage parts but replace them with new parts.
- Confirm that the female housing has a housing seal.
- Confirm that the male and female housing has a front holder and that they are in the set position after all terminals are inserted.
- The terminals, which are used for male and female connector, must have a wire seal.
- Confirm that the female housing has a lever and that it is in the pre-set position.

7.2 Taping

Apply tape in such a manner that every individual wire is subjected to an equal amount of tensile force. Concentration of tensile force on a particular wire may cause harmful effect such as inadvertent disengagement of terminal.

7.3 Inspection

Any tool used for wiring and continuity inspection shall have the accuracy equivalent to that of the counterpart.

7.4 Notice Packing Of Wiring Harness

The wiring harness's packing configuration should avoid damaging connectors caused by external forces to the housing after wire harness shipping and long term storage. All components should be checked for damage.

8. Component List

Sub-Assembly	Yazaki Part Number	Part Name
Male connector 7282-6493-30	7182-6493-30	Male Housing
	7158-5741	Front Holder
Male terminal	7114-4102-02 etc.	1.5 System Terminal
	7158-3030-50 etc	Wire Seal
Female connector 7283-6493-30	7183-6493-30	Female Housing
	7158-5740	Front Holder
	7137-2796-50	Housing Seal (Packing)
	7158-7384-30	Lever
Female terminal	7116-4102-02 etc.	1.5 System Terminal
	7158-3030-50 etc	Wire Seal
Dummy plug for male and female connector	7158-3032-60	Dummy plug

Title	Doc.No.	Rev.
1.5 mm System Sealed Connector Female 18P	YPES-15-584E	0
Any exploitation of this document, which is not permitted by Copyright, in particular to copy this document to pass it to third parties, to adapt it or to store it on microfilm or in systems of electronic data processing is forbidden without express authorization. Offenders are liable to damages. The communication of the content of this document to third parties of this document is forbidden by contract.		