

YESC 1.5 SYSTEM 防水
取扱説明書

注)
本取扱説明書は、発行先に対し連絡無しに
改訂する場合がありますのでご了承下さい。

矢崎総業株式会社
矢崎部品株式会社
2016.10.27

本説明書は、本製品をご使用頂く上で最低限必要な項目を記載したものです。
取扱の際には、本記載内容を遵守下さい。
矢崎は本内容を遵守しないで起こった損害または誤使用により起こった
損害に対しては責任を負いません。

目 次

1. 部品形状と機能	P. 3
1-1. オス端子	
1-2. メス端子	
1-3. オスハウジング	
1-4. メスハウジング	
2. 各部品の取扱いについて	P. 7
2-1. 受入検査時の検査項目	
2-2. 部品の運搬、保管及び取扱い注意事項	
3. 端子圧着仕様	P. 9
3-1. 圧着規格	
3-2. クリンプハイト及びクリンプワイドの測定器と測定方法	
3-3. 端子圧着時の注意事項と判定基準	
3-4. ベンドアップ/ベンドダウンの測定方法	
4. 端子圧着済品の取扱い	P. 16
5. 端子とフロントホルダの組付け	P. 17
5-1. オス・メス端子のハウジングへの挿入	
5-2. オスフロントホルダの組付け(本係止作業)	
5-3. メスフロントホルダの組付け(本係止作業)	
6. 端子とフロントホルダの取外し	P. 20
6-1. オスフロントホルダ装着・解除治具	
6-2. 端子の抜き治具	
6-3. オスフロントホルダの本係止解除	
6-4. メスフロントホルダの本係止解除	
6-5. オス・メス端子取外し	
7. 防水栓の組付け及び取外し	P. 25
7-1. 防水栓組付け	
7-2. 防水栓取外し	
8. ワイヤハーネス組み立て	P. 26
8-1. ワイヤハーネス組立て時の注意事項	
8-2. 導通検査時の注意事項	

9. ワイヤハーネス梱包時の注意事項	P. 28
10. コネクタのかん合・離脱	P. 30
10-1. コネクタのかん合	
10-2. コネクタの離脱	
11. CPAの係止と解除	P. 31
11-1. CPAの係止	
11-2. CPAの解除	
◎ 構成部品一覧表	別紙 1～11

1. 部品形状と機能
1-1. オス端子

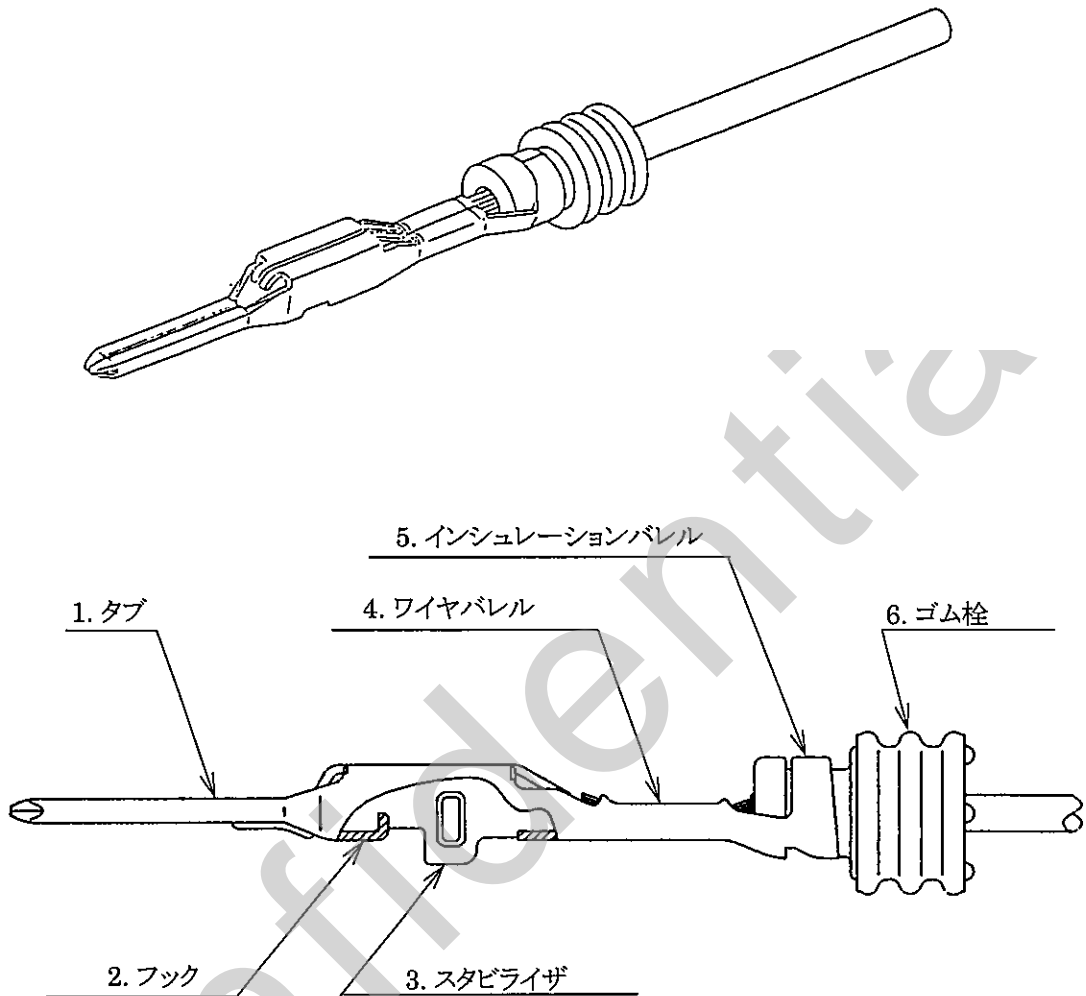

No.	名称	機能
1	タブ	メス端子との接触
2	フック	オスハウジングとの係止
3	スタビライザ	ハウジングへの逆挿入防止
4	ワイヤバレル	芯線圧着
5	インシュレーションバレル	絶縁体圧着
6	ゴム栓	電線とハウジング間の防水

1-2. メス端子

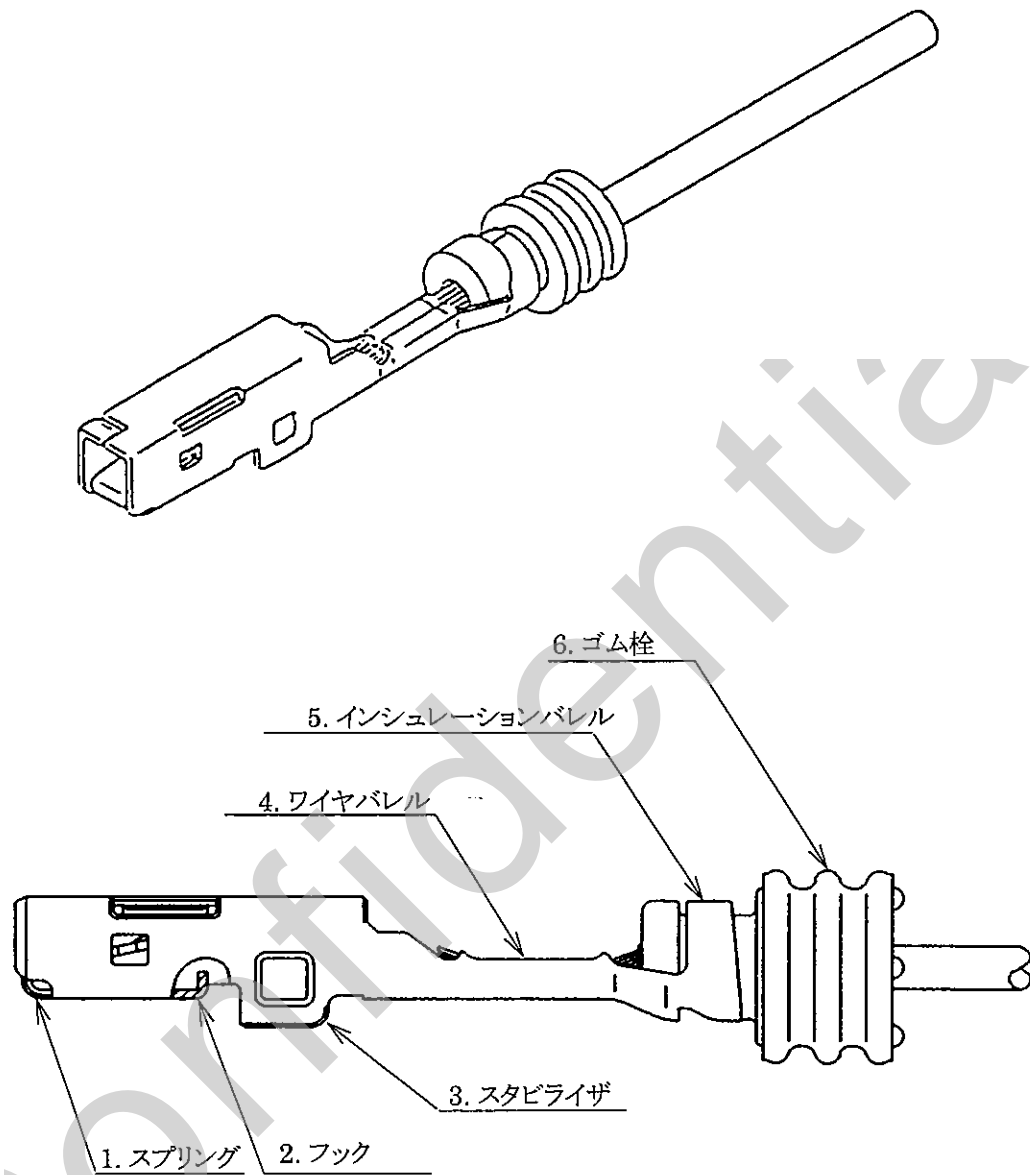

No.	名称	機能
1	バネ	オス端子との接触
2	フック	メスハウジングとの係止
3	スタビライザ	ハウジングへの逆挿入防止
4	ワイヤバレル	芯線圧着
5	インシュレーションバレル	絶縁体圧着
6	ゴム栓	電線とハウジング間の防水

1-3. オスハウジング

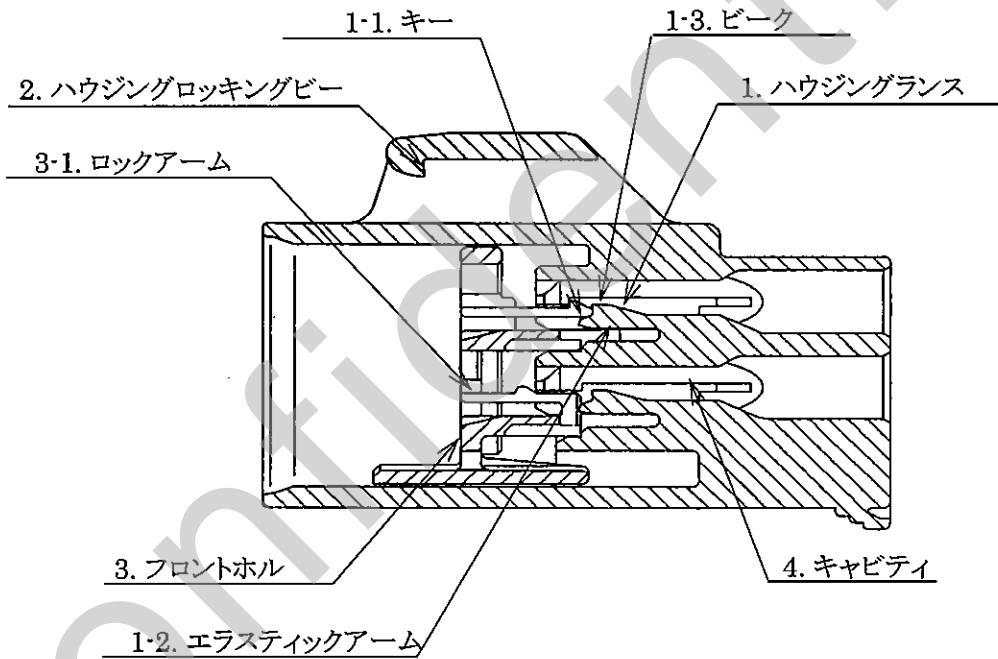
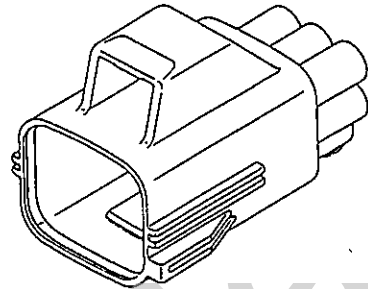

No.	名称		機能	
1	ハウジングランス	1-1	キー	ビークの解除操作
		1-2	エラスティックアーム	ビーク保持
		1-3	ビーク	オス端子との係止
2	ハウジングロックンクビーク		メスハウジングとの係止	
3	フロントホルダ		端子中途挿入検知	
	3-1	ロックアーム	フロントホルダの装着と解除	
4	キャビティ		端子収容部	

1-4. メスハウジング

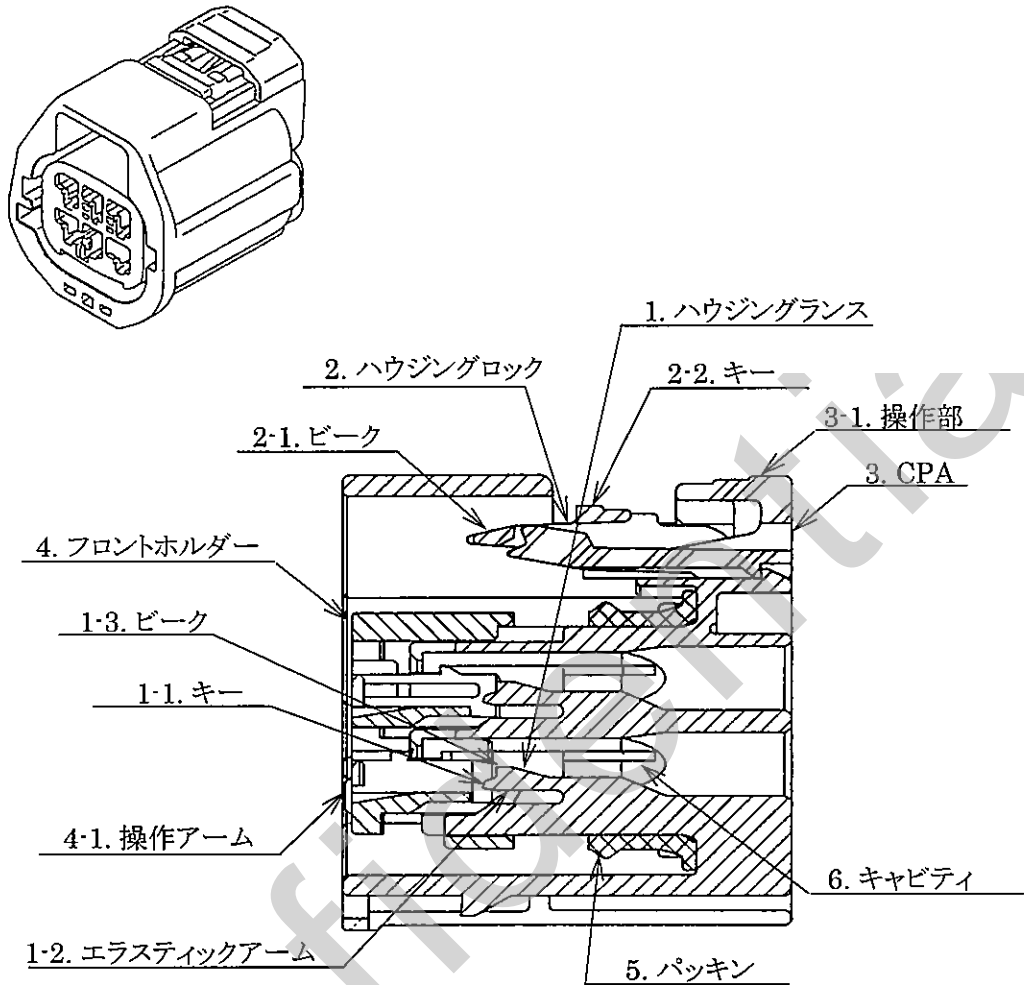

No.	名称		機能	
1	ハウジング ランス	1-1	キー	ビークの解除操作
		1-2	エラスティックアーム	ビーク保持
		1-3	ビーク	メス端子との係止
2	ハウジング ロック	2-1	ビーク	オスハウジングとの係止
		2-2	キー	ハウジングロックの解除操作
3	CPA (オプション)		コネクタ中途嵌合検知	
	3-1	操作部	CPAの操作	
4	フロントホルダ		端子中途挿入検知	
	4-1	操作アーム	フロントホルダの装着と解除	
5	パッキン		オス・メスハウジング間の防水	
6	キャビティ		端子収容部	

2. 各部品の取扱いについて

2-1. 受入検査時の検査項目

部品受入時には、下記項目について検査を行って下さい。

1) 端子

- ・ 異物、異品の混入
- ・ バリ、クラック、変形、傷
- ・ 変色、錆、汚れ、めっき剥がれ

2) ハウジング、ゴム栓、防水栓

- ・ 異物、異品の混入
- ・ バリ、ヒケ、ダレ、欠け、クラック、ショートショット、変形、傷

2-2. 部品の運搬、保管及び取扱い注意事項

各部品の運搬・保管には次の内容を守り、変形や損傷を防いで下さい。また、部品組立て工程などでの製品使用環境・組付け条件の下での安全な取扱いにつきましては、適時弊社営業担当に問い合わせ下さい。

2-2-1. 端子

端子は、リールからのほつれを防ぐため、針金などでしっかりとリールに固定して下さい。運搬・保管は、下記の方法で行って下さい。

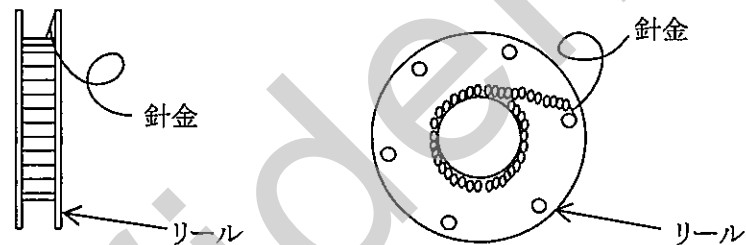

良い例	悪い例
<p>2段積みまでとして下さい。</p>	<p>(無保護状態での保管)</p>

運搬について

- ・ リールは紙製なので、破損しないように注意して下さい。
- ・ 運搬時の衝撃を避けるため、梱包(保護)して下さい。
梱包時には、部品が変形や損傷を受けることがないように十分注意して下さい。
- ・ 落下などによる、強い衝撃を与えないように十分注意して下さい。

保管について

- ・ 端子(リール)は、運搬時に使用する梱包箱に入れて保管して下さい。
特に水、埃、油、有毒ガスから保護して、無保護状態で保管しないで下さい。
- ・ 端子(リール)は、直射日光を避け、室内で保管して下さい。
- ・ 端子(リール)は、高温多湿の場所を避けて保管して下さい。

2-2-2. ハウジング、ゴム栓、パッキン、フロントホルダー、防水栓

運搬について

- ・ 運搬時の衝撃を避けるため、梱包(保護)して下さい。
梱包時には、部品が変形や損傷を受けることがないように十分注意して下さい。
- ・ 落下などによる、強い衝撃を与えないように十分注意して下さい。

保管について

- ・ 部品は、運搬時に使用する梱包箱に入れて保管して下さい。
特に水、埃、油、有毒ガスから保護して、無保護状態で保管しないで下さい。
- ・ 部品は、直射日光を避け、室内で保管して下さい。
- ・ 部品は、高温多湿の場所を避けて保管して下さい。

3. 端子圧着仕様

3-1. 圧着規格

圧着規格については、適時弊社営業担当にお問い合わせ下さい。

<注記>

- ・圧着の際は、必ず規格内で圧着して下さい。規格外の場合、加締部の固着力・電気抵抗が維持できず、製品の機能に支障をきたす恐れがあります。
- ・本内容については、弊社の圧着型を使用した場合に限りです。

3-2. クリンプハイト及びクリンプワイドの測定器と測定方法

3-2-1. 測定器

マイクロメータを使用して測定して下さい。

マイクロメータは、下記仕様のアンビル、及びスピンドルを使用して下さい。

マイクロメータは、スタンドに固定して使用して下さい。

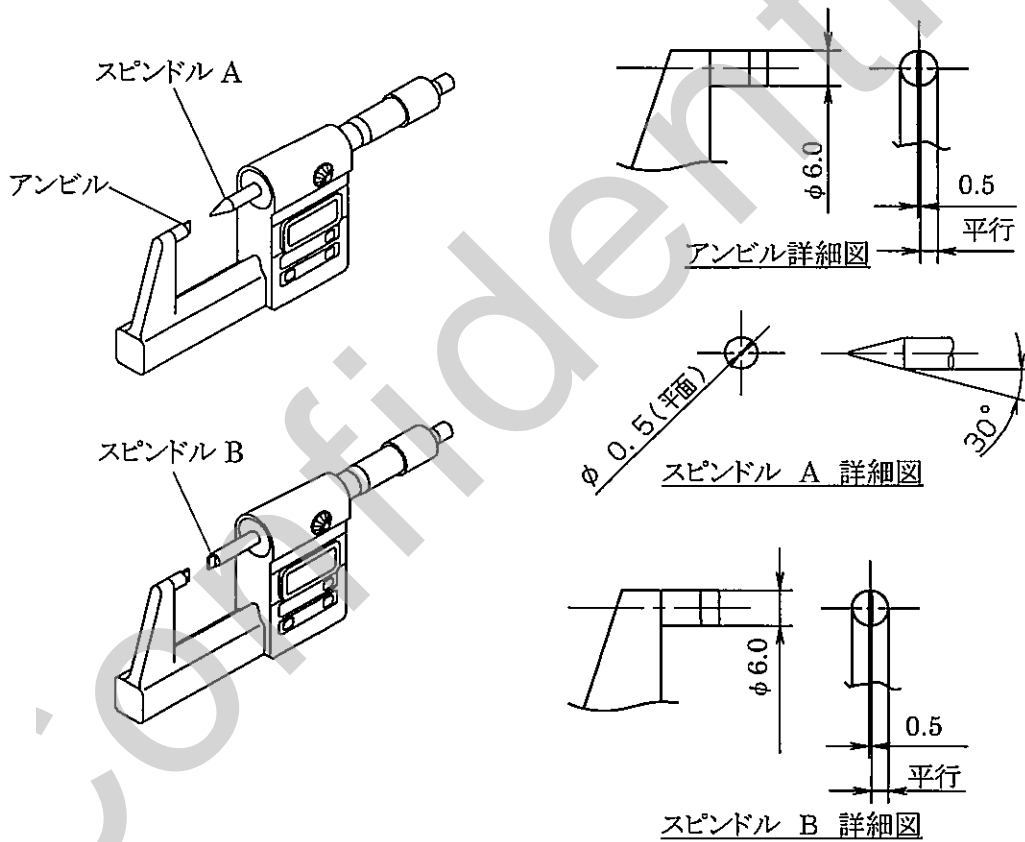

測定箇所	使用部品
ワイヤバレル クリンプハイト	スピンドル A
ワイヤバレル クリンプワイド	スピンドル B
インシュレーション クリンプハイト	
インシュレーション クリンプワイド	

3-2-2. 測定方法

芯線圧着部及び絶縁体圧着部の寸法は、それぞれの圧着部中央を測定して下さい。

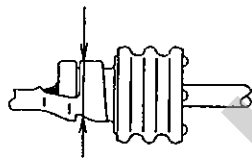
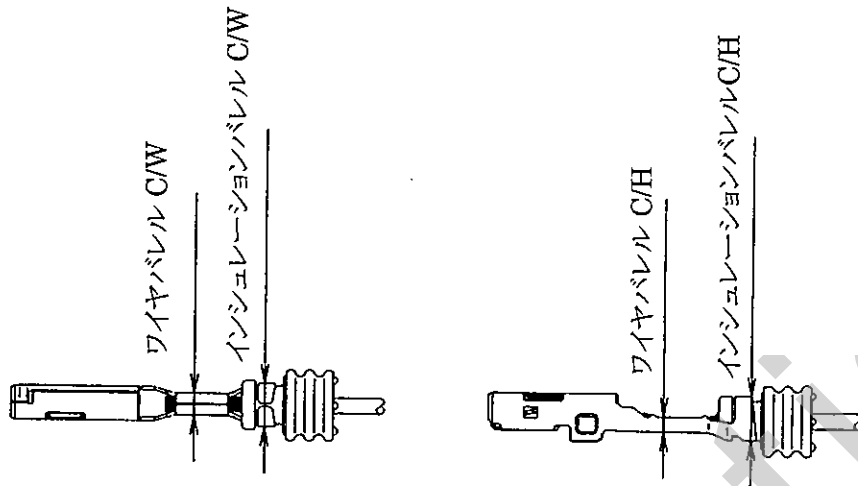

C/H: クリンプ高さ
C/W: クリンプワイド

<注意事項>

C/Hは、この地点では測定しないで下さい。
(段差のある部分では測定しないで下さい。)

ワイヤバレル: マイクロメータを用いて、下図のように挟んで測定して下さい。

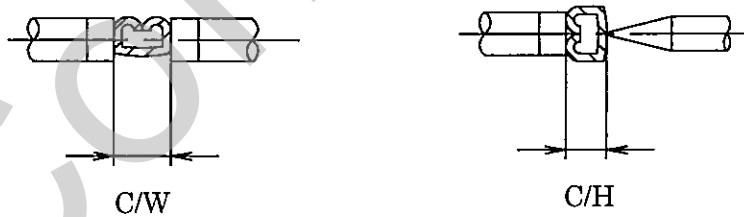

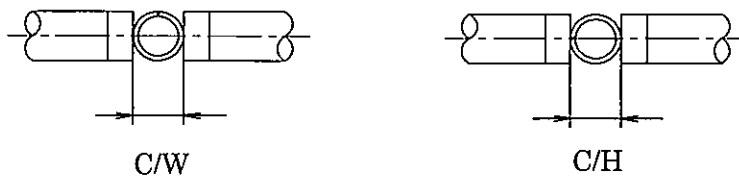

インシュレーションバレル: マイクロメータを用いて、下図のように挟んで測定して下さい。





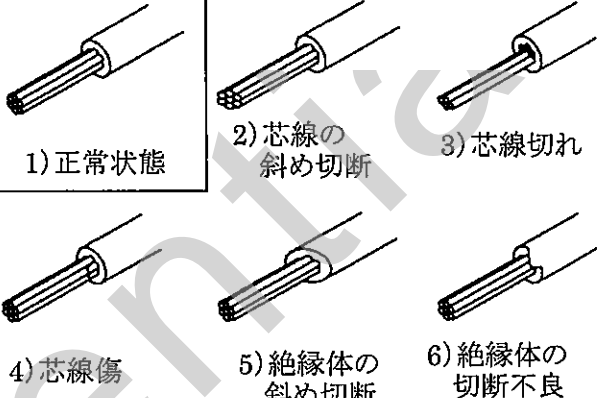
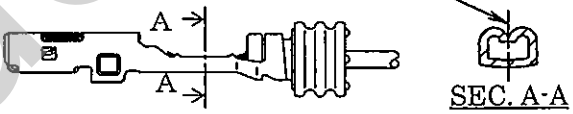
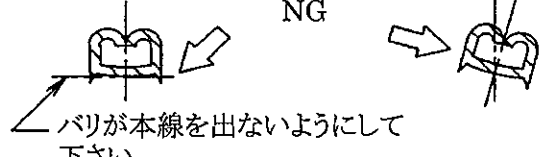
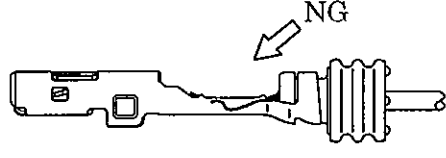
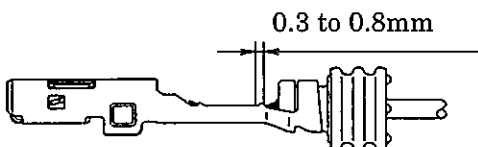
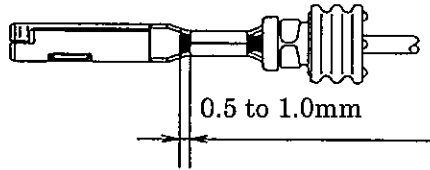

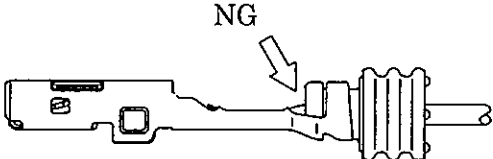
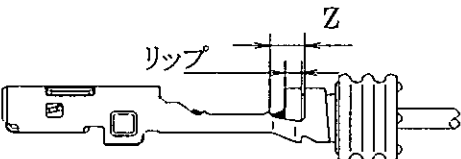
3-3. 端子圧着時の注意事項とチェック項目

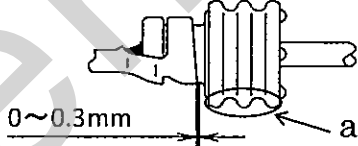
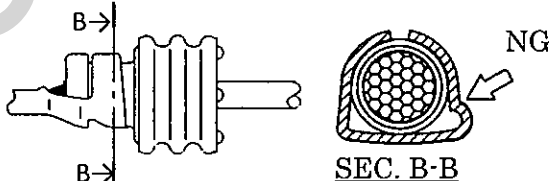
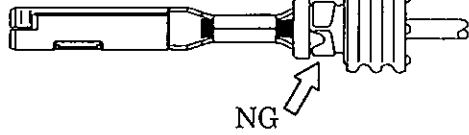
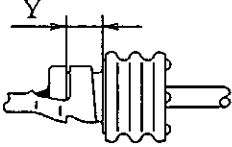
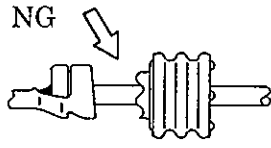
- ・皮むきした電線は、すぐに圧着作業を行って下さい。
移動や保管は、芯線がばらけやすく不良の原因となりやすいので、避けて下さい。
- ・変形や損傷した端子は絶対に使用しないで下さい。
- ・圧着後は、速やかにハウジングに組付けて下さい。すぐに組付けない場合は、端子部を清潔なビニール袋などで保護して下さい。
- ・端子圧着時には、下記の項目を確認して下さい。
表内に寸法指示がある項目は、指示寸法内で圧着して下さい。

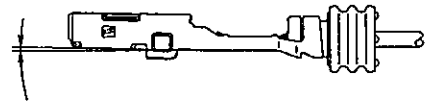
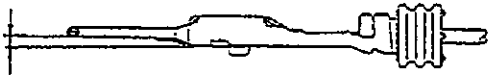

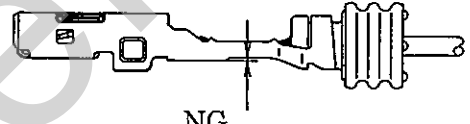
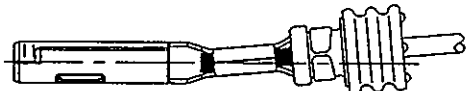
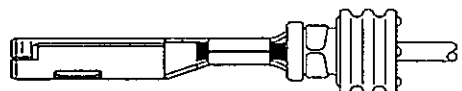

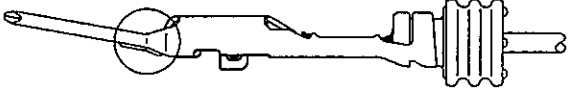
部位	チェック項目	
1. 電線	電線皮むき 1) 正常状態 2) 芯線の斜め切断 3) 芯線切れ 4) 芯線傷 5) 絶縁体の斜め切断 6) 絶縁体の切断不良	
2. 圧着部 ワイヤパレル (オス・メス)	1) 正常圧着状態	 <p>本線基準に左右対照にしてください</p>
	2) バリ及びびねじれ	 <p>NG</p> <p>バリが本線を出ないようにして下さい。</p>
	3) 芯線ほつれ	 <p>NG</p> <p>芯線がほつれているものは使用できません。</p>
	4) ベルマウス	 <p>0.3 to 0.8mm</p>
	5) 芯線飛び出し長さ	 <p>0.5 to 1.0mm</p>

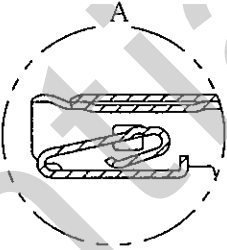
部位	チェック項目	
2. 圧着部 ワイヤバレル (オス・メス)	6) ワイヤバレルによる 絶縁体圧着状態	
3. 圧着部 インシュレー ションバレル (オス・メス)	1) 正常圧着状態	 <p>ゴム栓リップが、ワイヤバレルとインシュレーションの間(Z区間)にあることを確認して下さい。</p>
	2) 被覆圧着不足による ゴム栓落ち	
	3) つなぎ出し長さ	 <p>a部が傷付いていないことを確認して下さい。</p>
	4) しわ	
	5) ゴム栓噛込み	
	6) ゴム栓の位置	 <p>インシュレーションバレルがY区間にあることを確認して下さい。</p>
	7) ゴム栓の傷、切れ	 <p>傷及び切れがあるものは、使用できません。</p>

部位	チェック項目	
4. 圧着による端子の変形 (オス・メス)	1) ベンドアップ	<p>Max. 1° </p> <p>MAX. 1° </p> <p>ベンドアップ角度は1°以下とする。</p>
	2) ベンドダウン	<p>Max. 3° </p> <p>MAX. 3° </p> <p>ベンドダウン角度は3°以下とする。</p>
	3) ワイヤバレルの段付き	 <p>NG</p>
	4) ねじれ	 <p>目視でねじれが認められるものは使用できません。</p>
	5) 送り不良	<p>NG</p> 

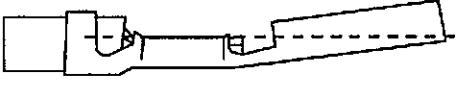
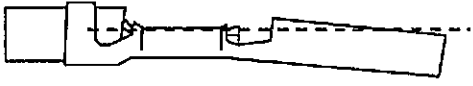
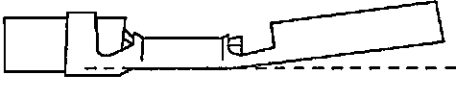
部位	チェック項目	
5. 圧着による端子の変形 (オス)	タブの変形	NG  目視で変形が認められるものは使用できません。
6. 圧着による端子の変形 (メス)	1) 箱の変形	 正常 NG
	2) 右図A部分の変形	 A部に変形があるものは使用できません。

3-6 ベンドアップ/ダウンの測定方法

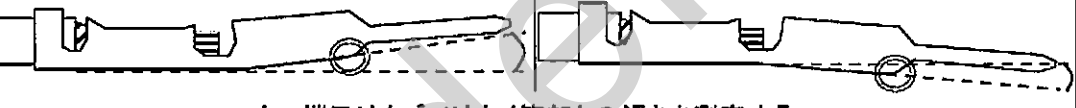
手順	ベンドUP	ベンドDOWN
1	 <p>サンプルを側面向けでセットし、前足圧着面上部のフラット部分を基準線として決める。</p>	 <p>サンプルを側面向けでセットし、前足圧着面上部のフラット部分を基準線として決める。</p>
2	 <p>前足圧着面上部にセットした基準線を前足圧着面下部へ平行に移動させる(首部付け根)。</p>	 <p>前足圧着面上部にセットした基準線を前足圧着面下部へ平行に移動させる(首部付け根)。</p>
3	 <p>前足圧着面下部(首部付け根)に対して、箱下部フラット面の傾きを測定する。</p>	 <p>前足圧着面下部(首部付け根)に対して、箱下部フラット面の傾きを測定する。</p>
オス端子	 <p>オス端子はタブではなく箱部との傾きを測定する。</p>	

4. 端子圧着済品の取扱い

端子圧着済品は、運搬・保管中に変形や損傷が発生しやすいため、下記項目を守って下さい。

- ・ 端子圧着済品は、ばらばらにならないようにゴムなどで束ねて下さい。
束ね本数が多すぎると、端子同士の引っ掛かりによる変形や損傷の発生、自重による作業性の悪化が考えられますので、一束の本数は100本以下として下さい。
束ねる時に、端子先端を叩いて揃えないで下さい。
- ・ 端子圧着済品にはビニール袋を被せて、埃から保護して下さい。
- ・ 保管・運搬の際は保護カバーを使用し、ハウジングに組付ける直前まで外さないで下さい。
但し、端子圧着済品は変形や損傷しやすいので、端子圧着後は速やかにハウジングに組付けてください。
- ・ 運搬は、線架台又は蓋付きのポリケース通い箱にて行い、積み重ねしないで下さい。
- ・ 投げ込みや投げ降しは絶対にしないで下さい。

端子圧着済み電線の処理例

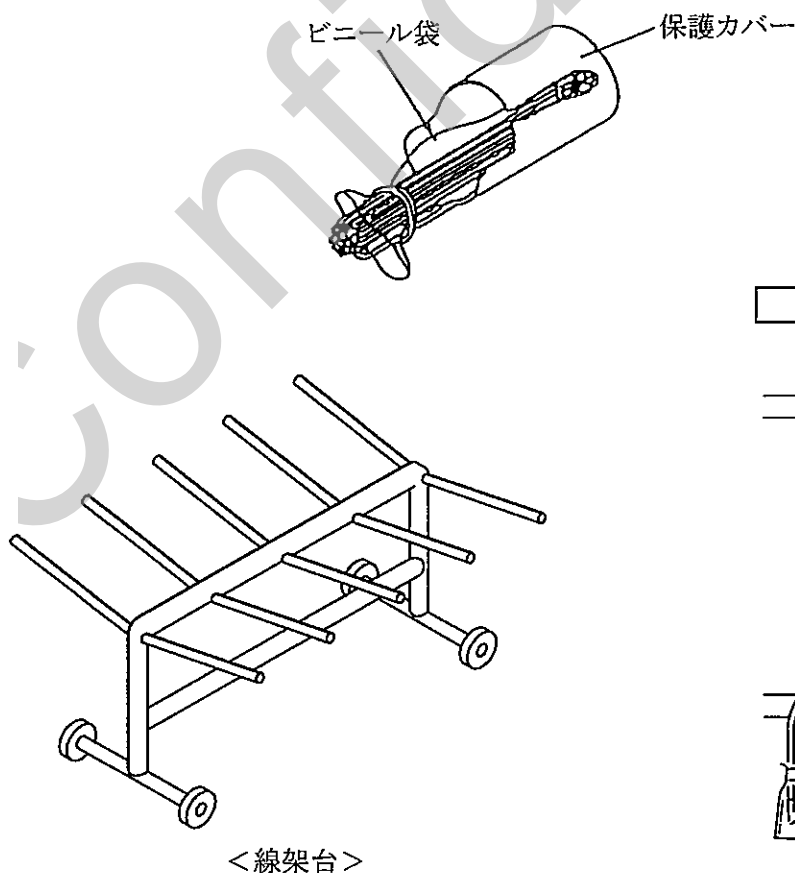

5. 端子とフロントホルダの組付け

5-1. オス・メス端子のハウジングへの端子組付け

- 1) 端子の挿入前にフロントホルダが仮係止位置にあることを確認して下さい。
フロントホルダが仮係止位置でない時は、仮係止位置に戻してから作業を行って下さい。
(6-3、6-4. 参照)
- 2) 端子及びゴム栓に変形や損傷がないか確認して下さい。
- 3) 下図のように、端子とハウジングの向きを合わせ、端子をハウジングに挿入して下さい。
端子が係止する時の「カチン」という音を確認して下さい。
- 4) 電線を軽く引っ張って、端子が確実に係止されていることを確認して下さい。
- 5) ゴム栓後端が、ハウジングの端子挿入口より中に入っていることを確認して下さい。

オス

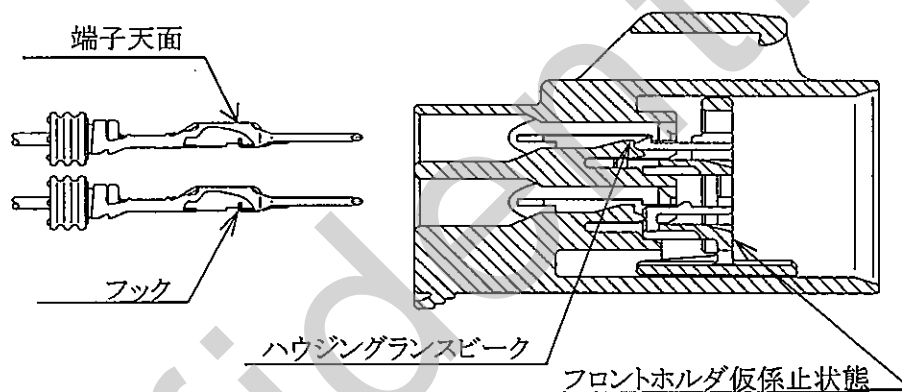

メス

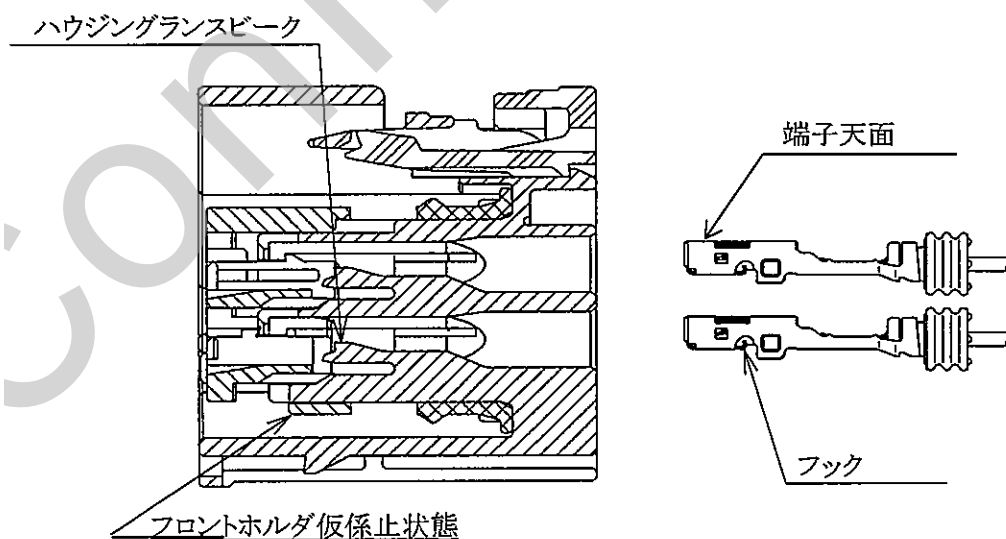

<注意事項>

- ・ 部品を変形させないで下さい。
変形や損傷してしまった場合は、新しい部品と交換して下さい。

5-2. オスフロントホルダの組付け(本係止作業)

- 1) 端子挿入後、治具(6-1.参照)でA部を矢印1の方向へ押し、フロントホルダを本係止位置に動かして下さい。
- 2) フロントホルダが確実に本係止されていることを確認して下さい。

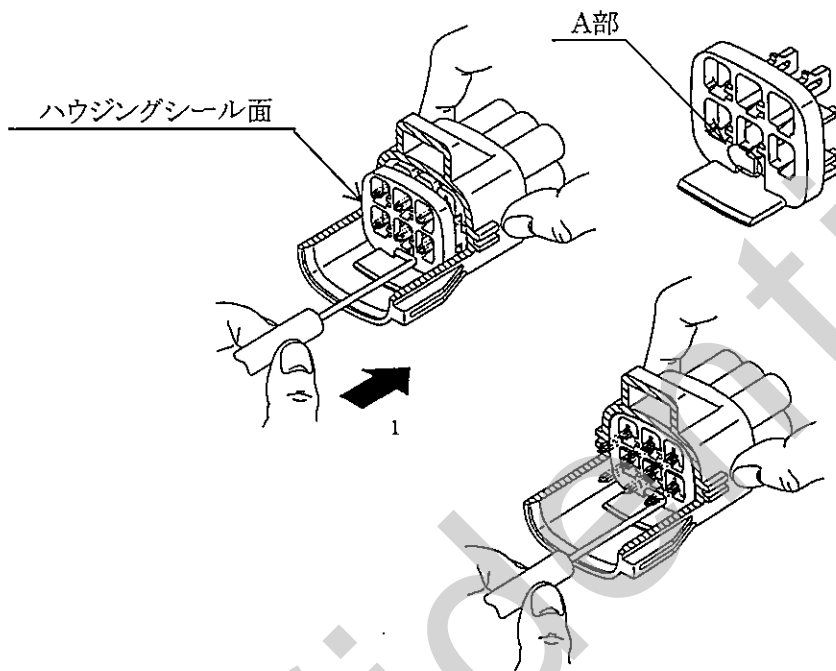

<注意事項>

- ・ A部を押し際は、ハウジングシール面やおすタブを治具で傷付けないで下さい。ハウジングシール面やおすタブを傷付けてしまった場合は、新しい部品と交換して下さい。
- ・ 下記の状態にある場合、フロントホルダを本係止出来ません。
 - * 端子がキャビティ内へ完全に挿入されていない。(端子中途挿入状態)
 - * 端子が誤方向で挿入されている。(端子逆挿入状態)
 無理に押し込んでしまった場合は、新しい部品と交換して下さい。

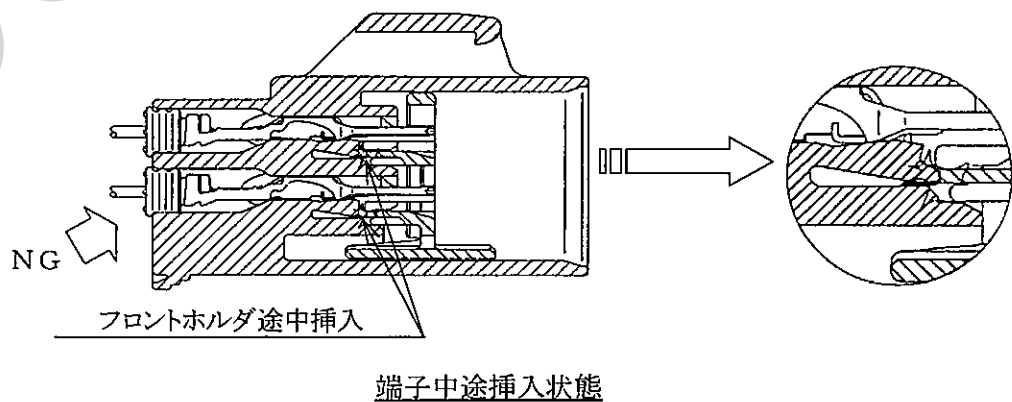

5-3. メスフロントホルダの組付け(本係止作業)

- 1) 端子挿入後、操作アームを矢印1の方向へたわませて、フロントホルダを矢印2の方向に動かして本係止して下さい。
- 2) フロントホルダが確実に本係止されていることを確認して下さい。

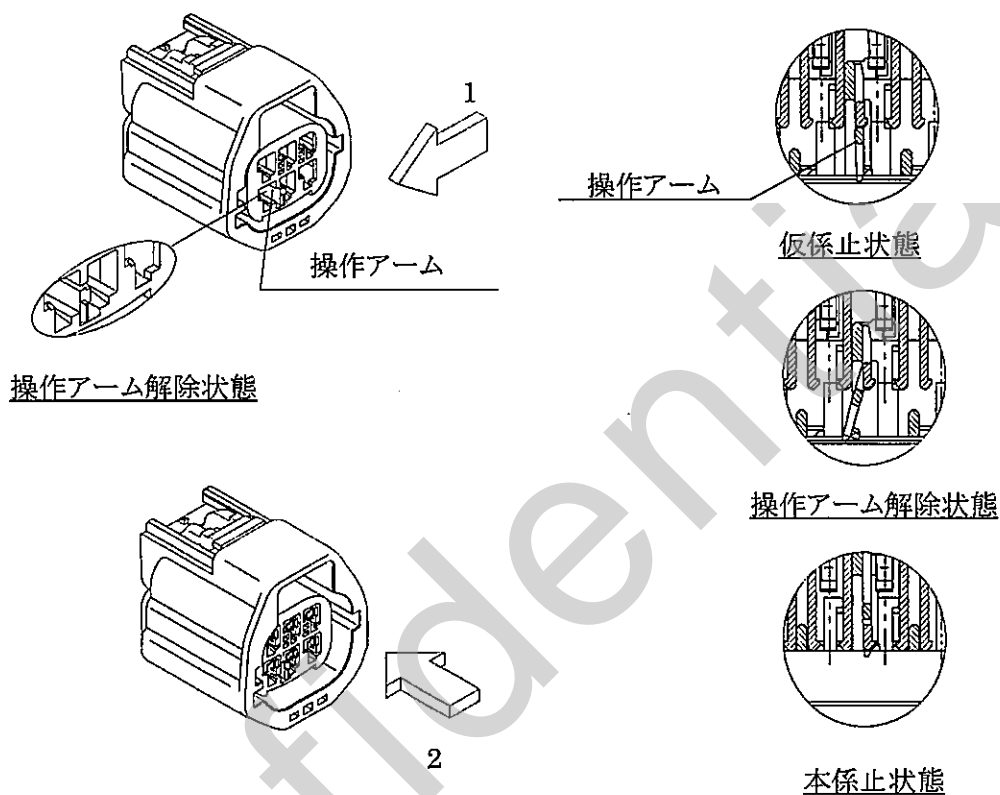

<注意事項>

- ・ 操作アームを作用させないで作業を行うと、フロントホルダやハウジングを破損する可能性があります。
- ・ 操作アームは変形しやすいため、必要以上にたわませないで下さい。
操作アームが変形した場合は、新しい部品と交換して下さい。
- ・ 部品を変形させないで下さい。
変形や損傷させてしまった場合は、新しい部品と交換して下さい。
- ・ 下記の状態にある場合、フロントホルダを本係止出来ません。
 - * 端子がキャビティ内へ完全に挿入されていない。(端子中途挿入状態)
 - * 端子が誤方向で挿入されている。(端子逆挿入状態)
 無理に押し込んでしまった場合は、新しい部品と交換して下さい。

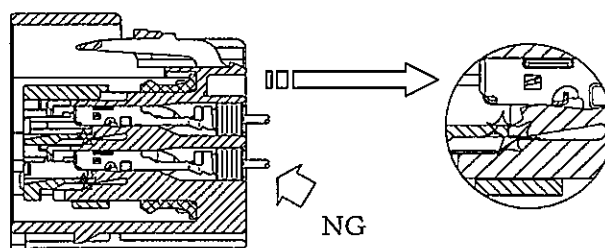

端子中途挿入状態

6. 端子とフロントホルダの取外し
6-1. オスフロントホルダ装着・解除治具
下記の治具を使用して下さい。

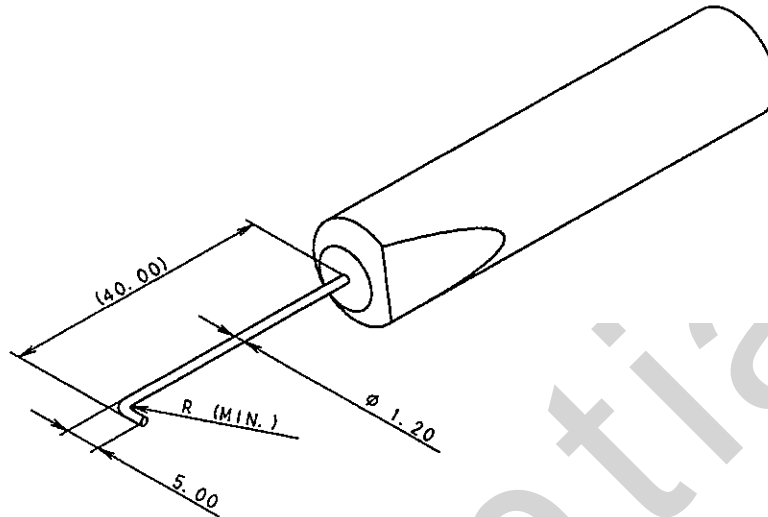

抜き治具品番: 49YF000002 (1-35)

- 6-2. 端子の抜き治具
下記の治具を使用して下さい。

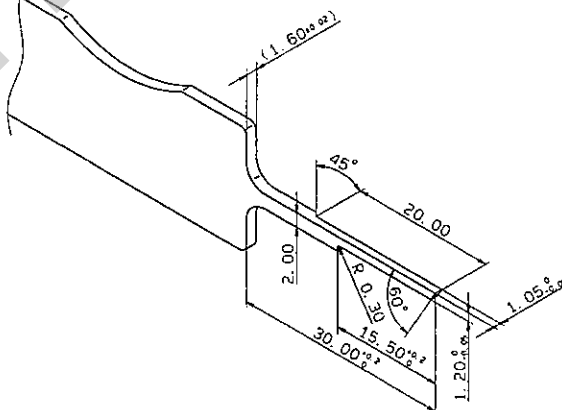

抜き治具品番: 49YA000146(48ZZ4009)

6-3. オスフロントホルダの本係止解除

- 1) 下図に示すように治具(6-1.参照)をフロントホルダの治具挿入口に挿入して下さい。
- 2) 治具を矢印1の方向に軽く引っ張り、フロントホルダを仮係止位置に移動させて下さい。
- 3) フロントホルダが確実に仮係止位置に戻っていることを確認して下さい。

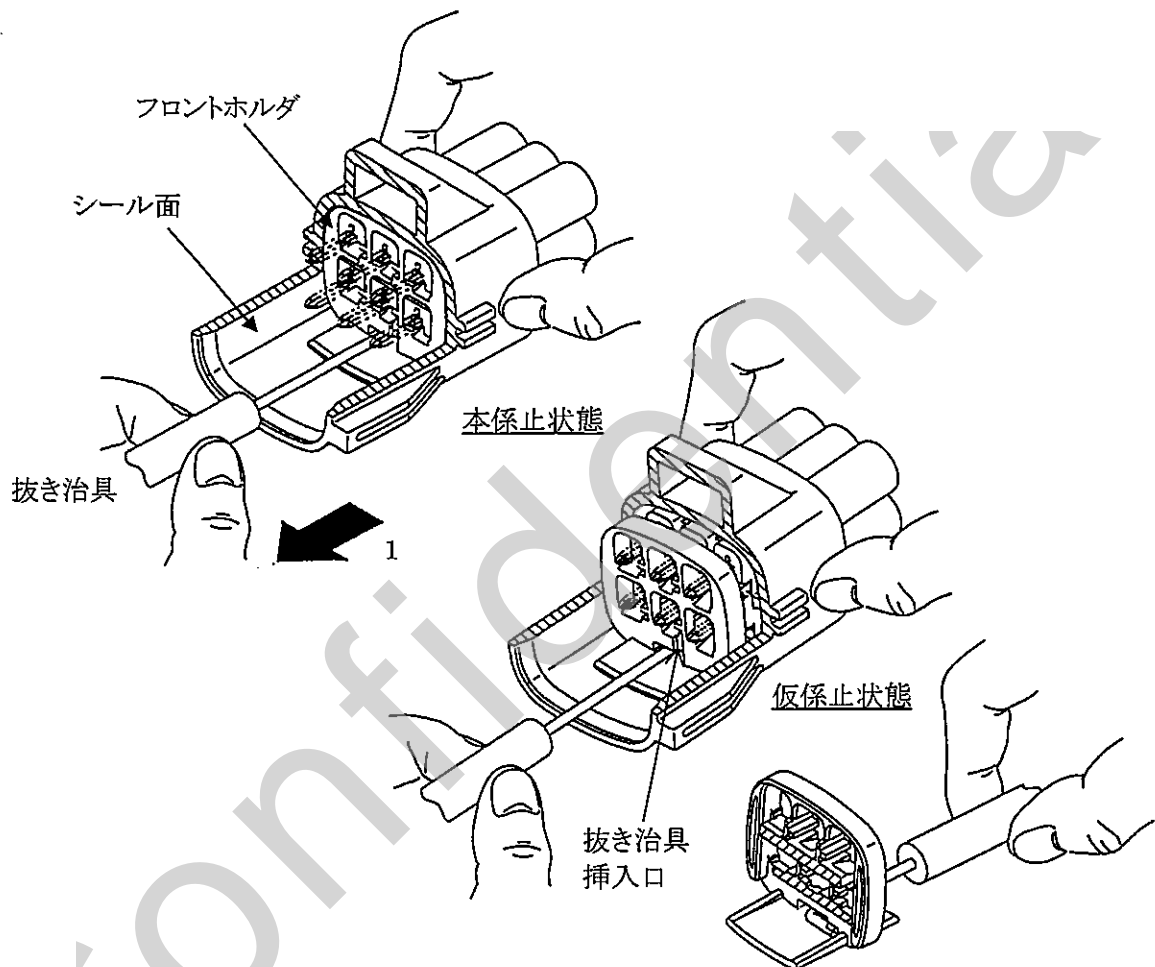

<注意事項>

- ・ 治具でハウジングシール面やオスタブを傷付けないで下さい。
- ・ 部品を変形、損傷させないで下さい。
変形や損傷させてしまった場合は、新しい部品と交換して下さい。

6-4. メスフロントホルダの本係止解除

- 1) 下図に示すように操作アームを矢印1の方向へ動かして下さい。
- 2) そのままの状態、フロントホルダを矢印2の方向へ引き出し、仮係止位置に動かして下さい。
- 3) フロントホルダが確実に仮係止位置に戻っていることを確認して下さい。

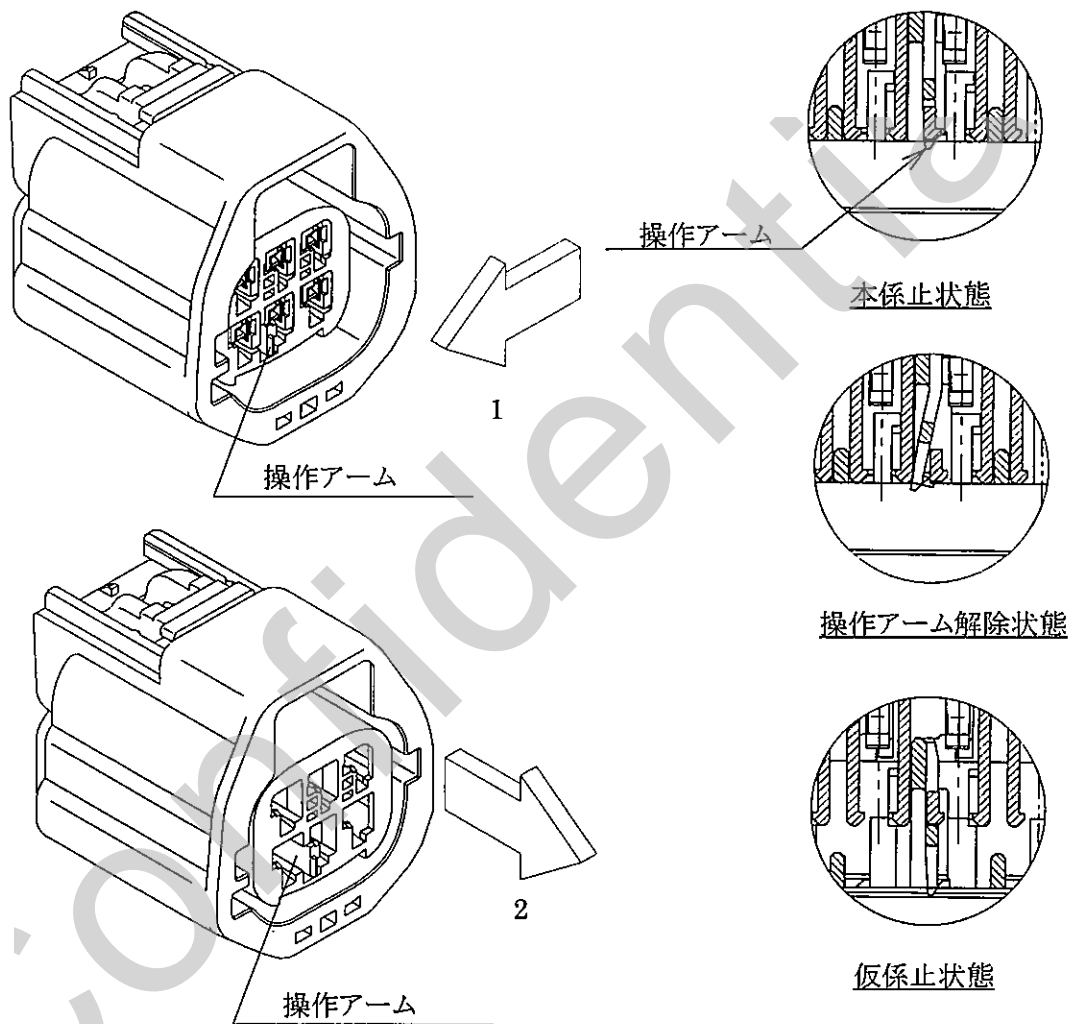

<注意事項>

- ・ フロントホルダの操作アームは変形しやすいため、必要以上たわませないで下さい。操作アームを変形させてしまった場合は、新しいハウジングに交換して下さい。
- ・ 部品を変形、損傷させないで下さい。変形や損傷させてしまった場合は、新しい部品と交換して下さい。

6-5. オス・メス端子取外し

- 1) キャビティ面(端子抜き治具ガイド面)に沿って抜き治具(6-2.参照)をセットして下さい。
(オス:ハウジング/メス:フロントホルダ)
- 2) 下図のように電線を矢印1の方向に軽く押し、抜き治具を矢印2の方向に真っ直ぐに挿入し、ハウジングのランス係止を解除して下さい。
- 3) そのまま、電線を矢印3の方向へ軽く引っ張り、端子をキャビティから抜いて下さい。

オス

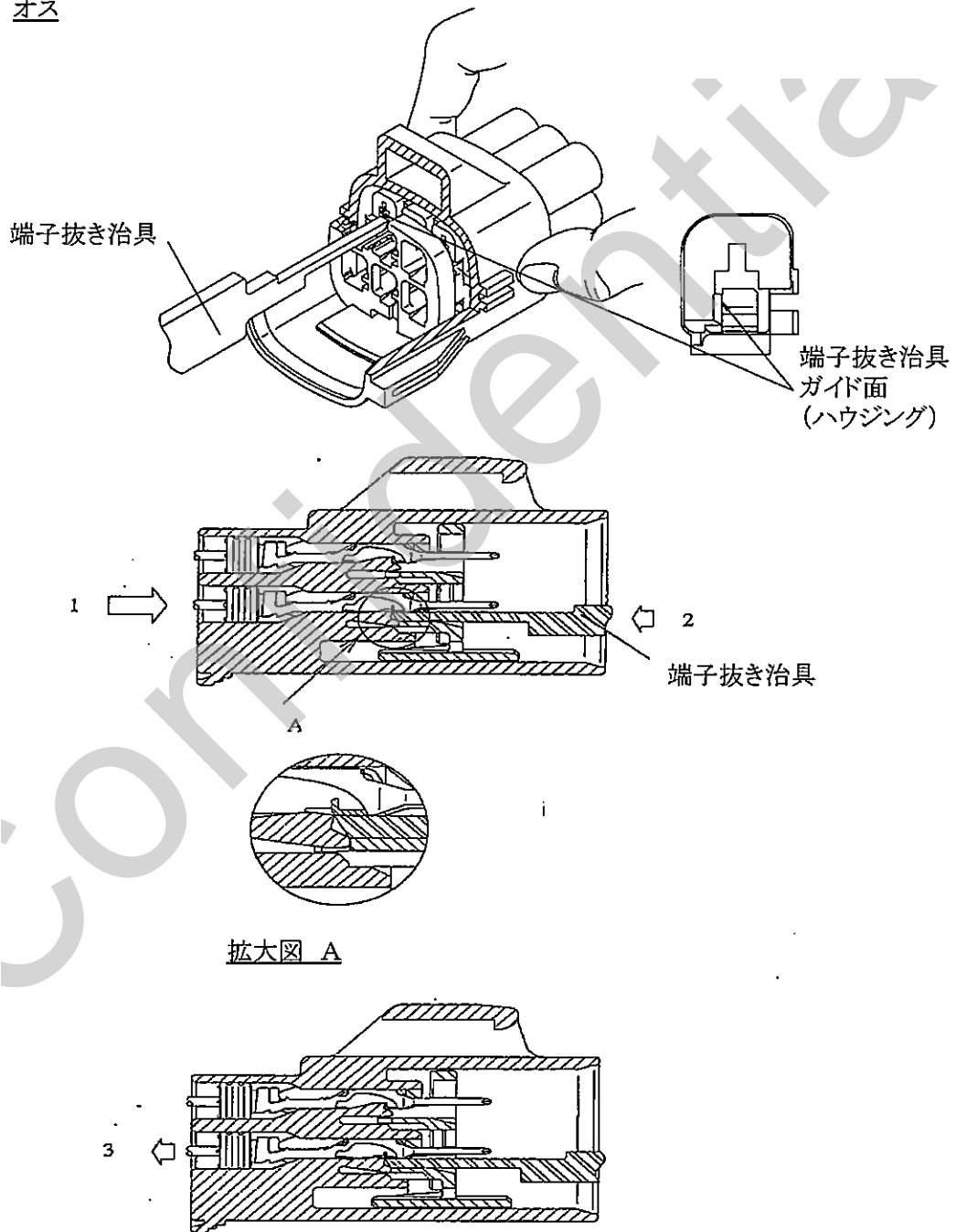

メス

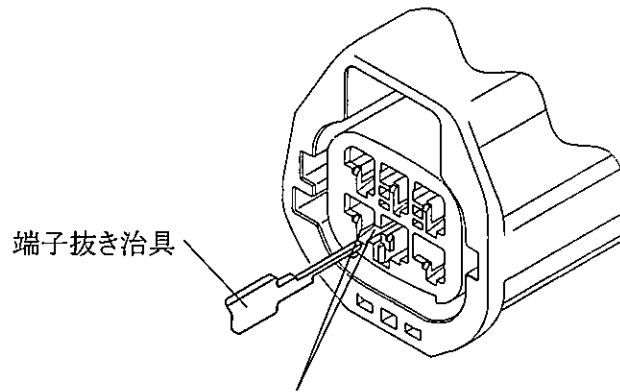

端子抜き治具ガイド面(フロントホルダ)

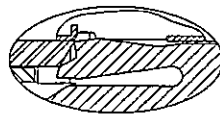

拡大図 A

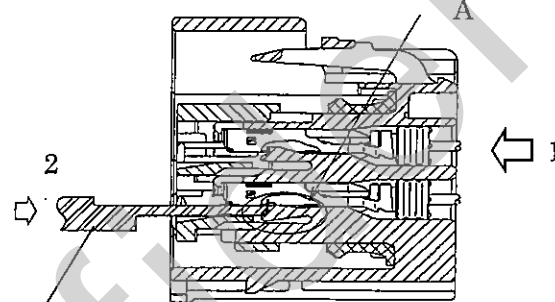

端子抜き治具

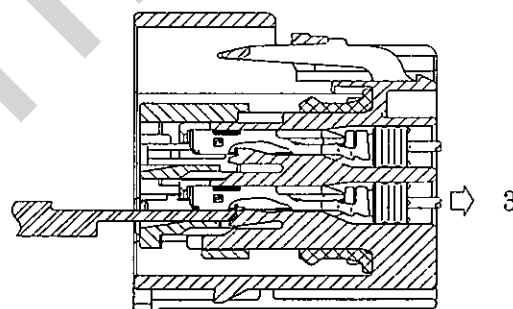

<注意事項>

- ・ 端子取外し操作は本取扱説明書の作業徹底が出来る様十分に教育された技術員によって行って下さい。
取外し過程において十分に教育されていない技術員によって端子抜き作業をすることは、端子やコネクタにダメージを与える結果となります。
- ・ 端子がハウジングから容易に抜けない場合は、上記の作業を最初からやり直して下さい。
- ・ ランスを破損する恐れがあるため、抜き治具を挿入する際はハウジングに対し挿入し、押し込み過ぎないように注意して下さい。
- ・ 部品を変形や損傷させないで下さい。
変形や損傷させてしまった場合は、新しい部品と交換して下さい。

7. 防水栓の組付け及び取外し

7-1. 防水栓組付け

- 1) 防水栓は、端子が挿入されないキャビティに指で押し込んで下さい。

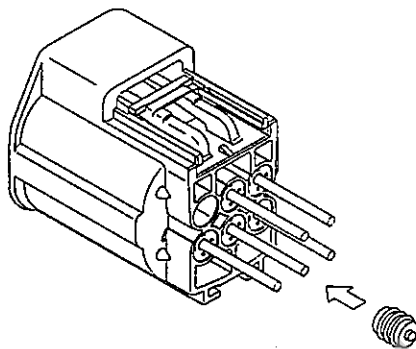

- 2) 防水栓の後部がキャビティから飛び出していないことを確認して下さい。

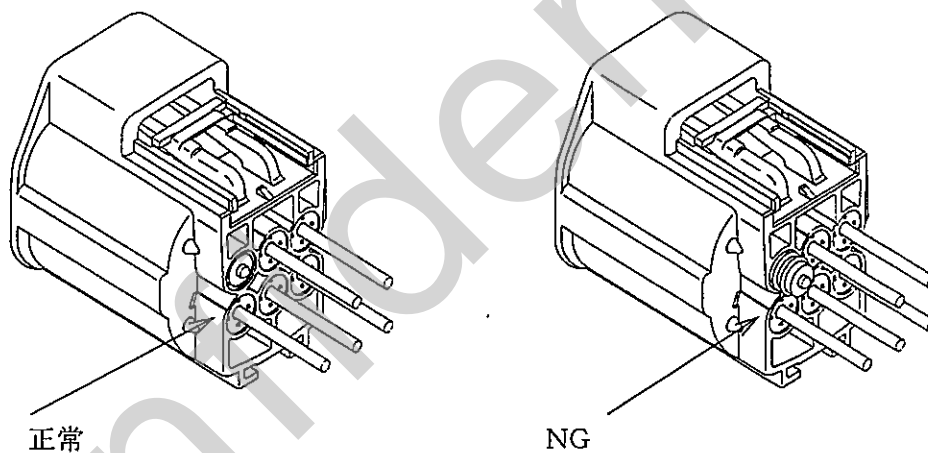

7-2. 防水栓取外し

防水栓は、指やペンチなどでキャビティから引き抜いて下さい。

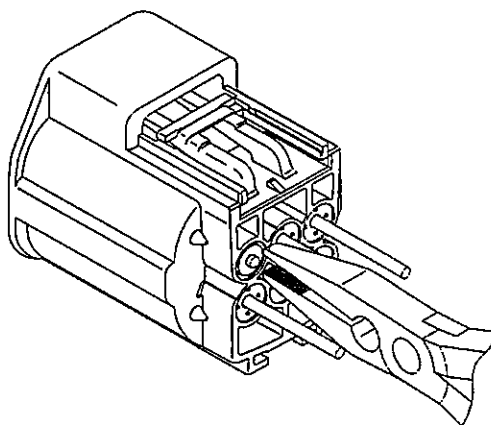

8. ワイヤハーネス組み立て

8-1. ワイヤハーネス組立て時の注意事項

- 1) 超音波にて部品（電線、端子など）の接続を行う場合は、部品に悪影響を及ぼさないことを確認の上行って下さい。
- 2) 全ての電線に均一な引張力がかかるようにテープ巻きを行って下さい。
特定の電線が突っ張るようなテープ巻きをすると、引張力がその電線に集中し、端子抜けなどの悪影響を及ぼします。

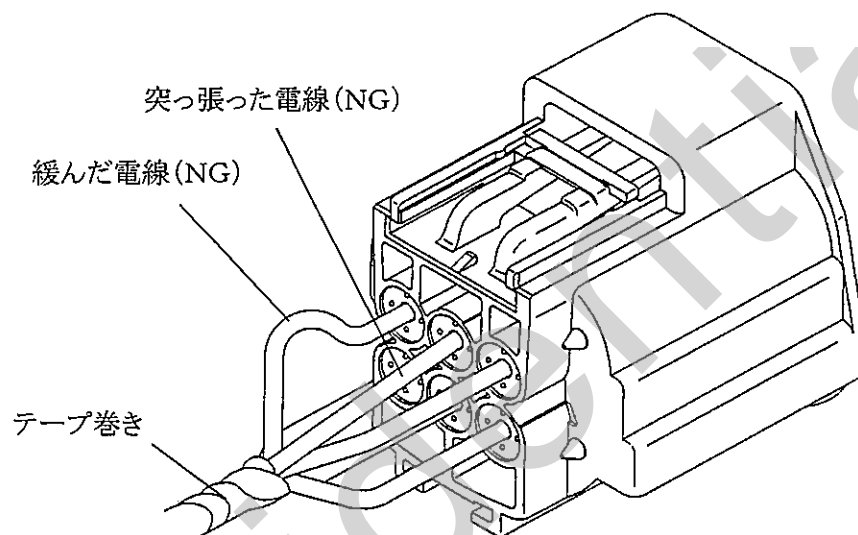

8-2. 導通検査時の注意事項

- 1) 配線検査や導通検査に使用する治具は、ハウジングや端子を破損しないように嵌合相手と同程度の精度として下さい。
- 2) 下図のように、ハウジングには導通検査ピン(プローブピン)が挿入できる溝が設定してあります。
この部位で導通検査を行って下さい。

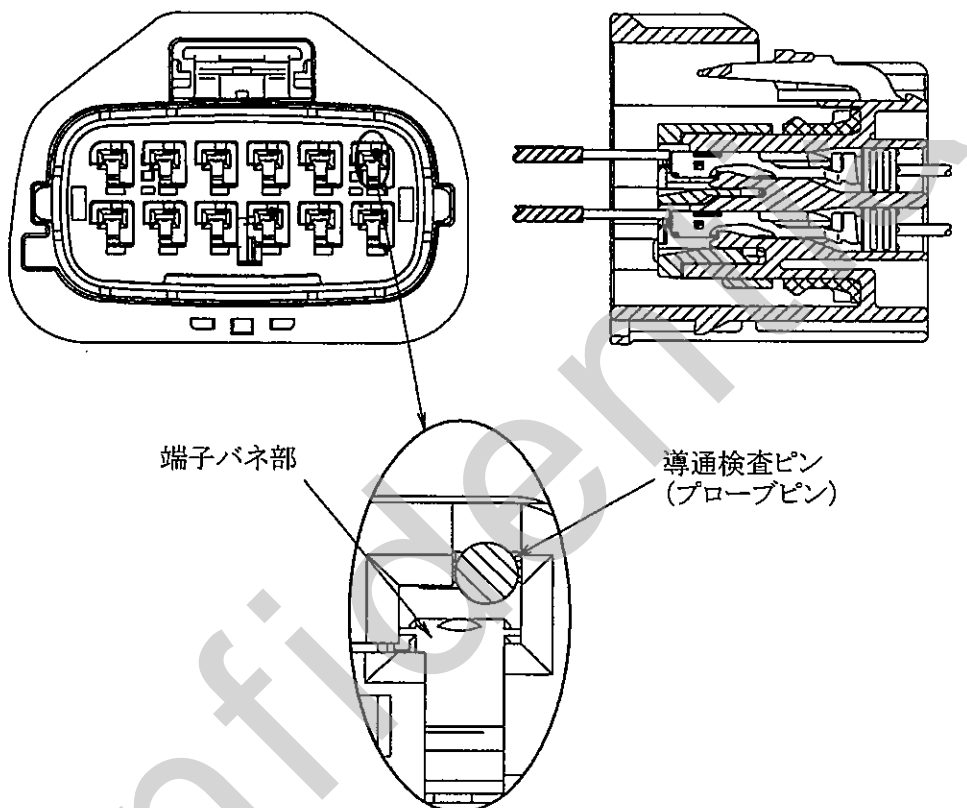

<注意事項>

部品を変形させないで下さい。

変形や損傷させてしまった場合は、新しい部品と交換して下さい。

9. ワイヤハーネス梱包時の注意事項

他の多くのプラスチック製品同様、コネクタも運搬や保管中に外力が加わると変形・損傷する可能性があります。

コネクタの変形や損傷を防ぐために、以下の指示に従って下さい。

- 1) ワイヤハーネスの梱包形態が多層となる場合、各ワイヤハーネスの荷重が他のワイヤハーネスのコネクタを変形・損傷させることがあります。
下図のように、各層毎にダンボールの縦・横仕切りや内部支えを使用し、荷重を均一にしてコネクタの変形や損傷を防いで下さい。

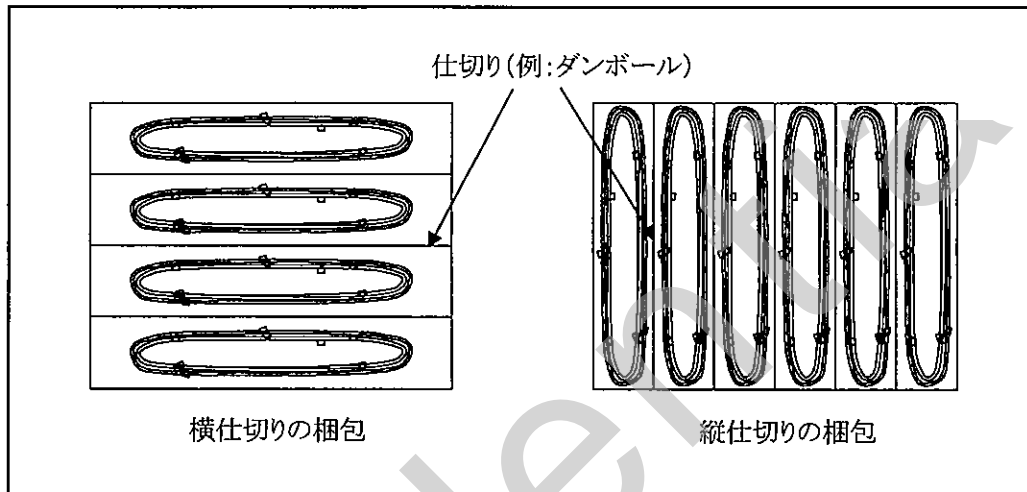

- 2) ジャンクションブロック、リレーボックス、プロテクター、ブラケットのような重いものや大きなものは、これらの部品の重量がコネクタに加わらないように、梱包箱や仕切りの底に配置して下さい。

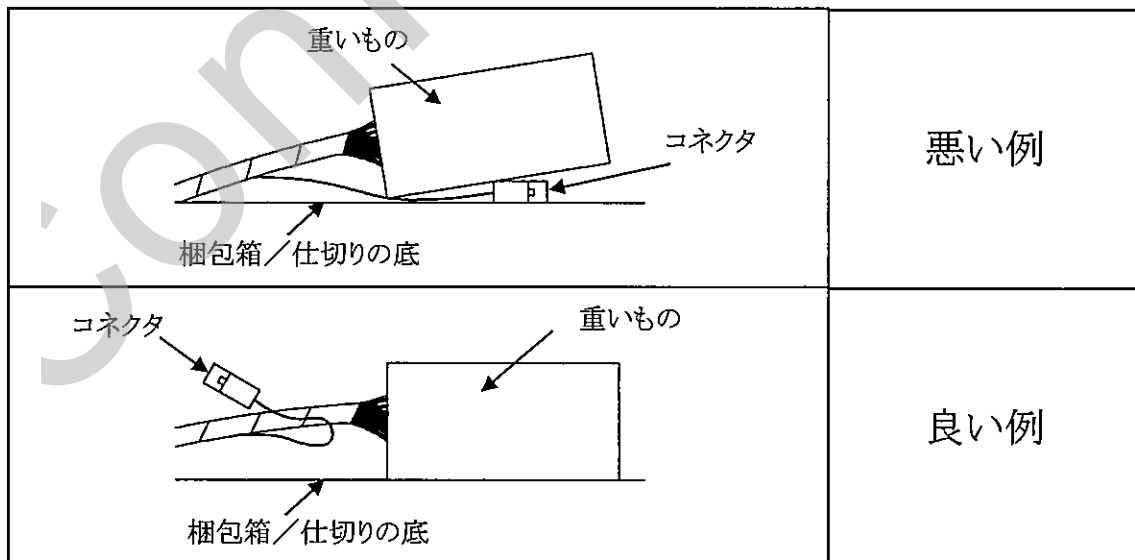

- 3) ワイヤハーネスの重量がかからないように、コネクタはワイヤハーネス束の外側か内側へ配置して下さい。

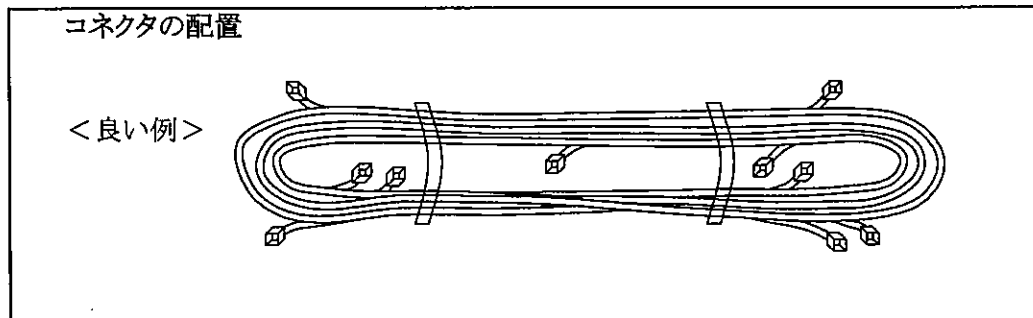

- 4) 運搬・保管中にワイヤハーネスが動かないように、梱包箱に合うサイズで束ねて下さい。

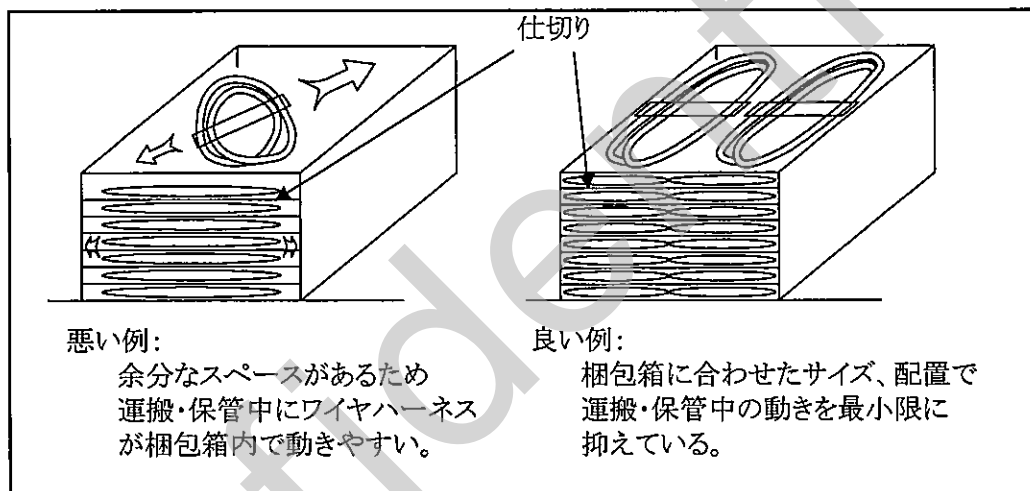

- 5) コネクタをワイヤハーネスにテープ止めする場合は、ハウジングロックや他の弾性部に電線束が当たらないような配置として下さい。

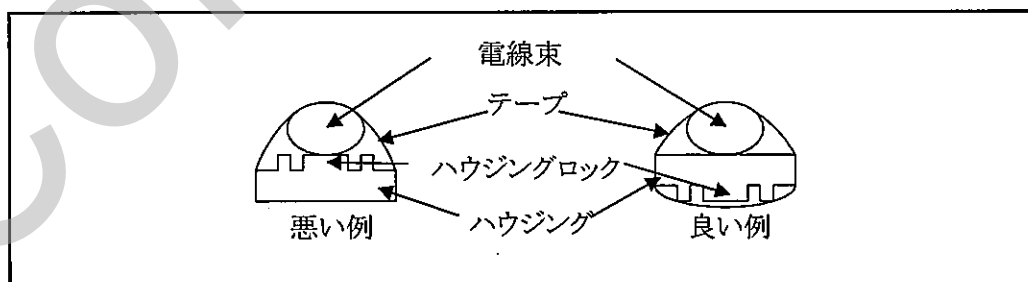

- 6) 車載のために梱包箱からワイヤハーネスを取り出す際は、ワイヤハーネスの絡みに注意し、コネクタの変形や損傷を防いで下さい。

- 7) 運搬・保管後には、コネクタに変形や損傷がないか確認して下さい。

10. コネクタの嵌合・離脱

10-1. コネクタの嵌合

- 1) フロントホルダが本係止されていることを確認して下さい。
- 2) 下図のような向きで、オス・メスコネクタが係止する時の「カチン」という音がするまで、矢印方向に押し込んで下さい。
- 3) オス・メスコネクタを軽く引っ張り、確実に係止していることを確認して下さい。

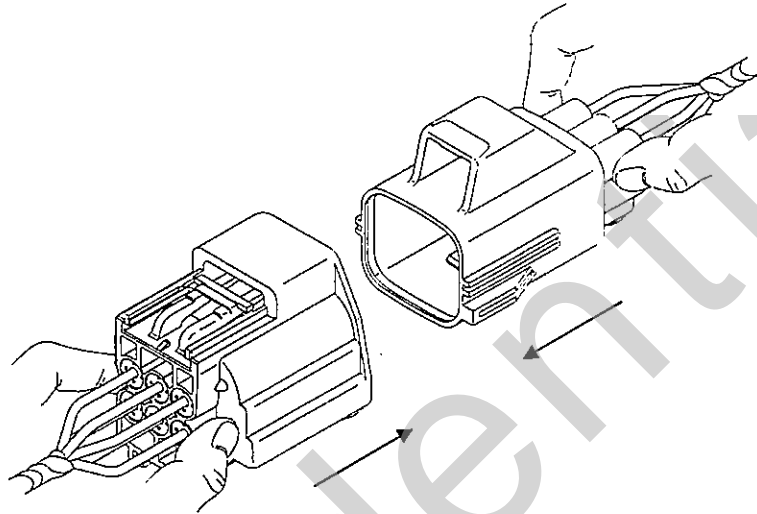

<注意事項>

- ・ こじらないで下さい。
- ・ハウジングロックキーを押しながら嵌合しないで下さい。

10-2. コネクタの離脱

- 1) ロックキーを押え、ハウジングロックを解除して下さい。
- 2) ロックキーを押えたまま、下図のようにオス・メスコネクタを矢印方向に引っ張って離脱して下さい。

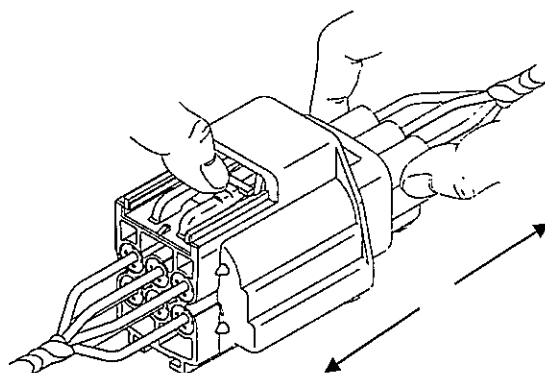

<注意事項>

- ・ 電線を持って引っ張らないで下さい。

11. CPAの係止と解除 (CPA: Connector Position Assurance)

11-1. CPAの係止

オス・メスコネクタが完全に嵌合した状態で、CPAのB部がコネクタA部に当たるまでスライドさせて下さい。

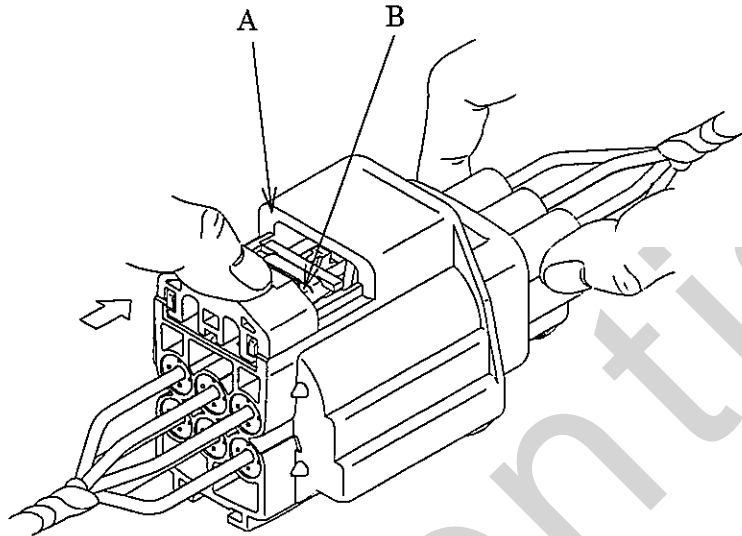

<注意事項>

CPAがスムーズにスライドしない場合は、コネクタの嵌合状態を確認して下さい。
コネクタが完全に嵌合していない場合、CPAのB部はコネクタA部までスライドできません。
(下図参照)

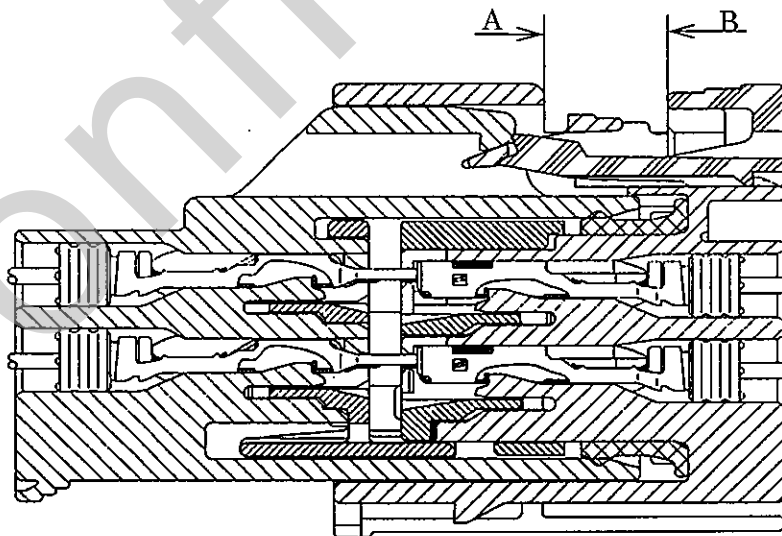

11-2. CPAの解除

下図のように、CPAを矢印方向にスライドさせて下さい。

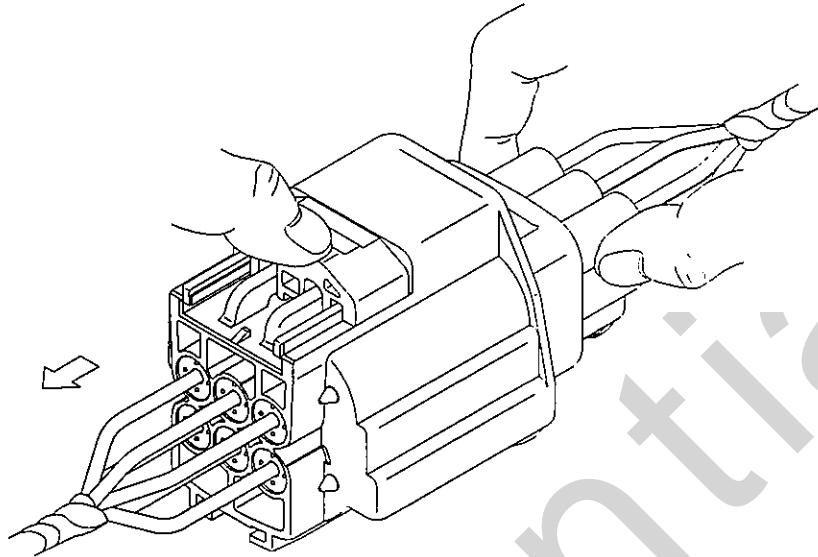

Confidential

構成部品一覧表

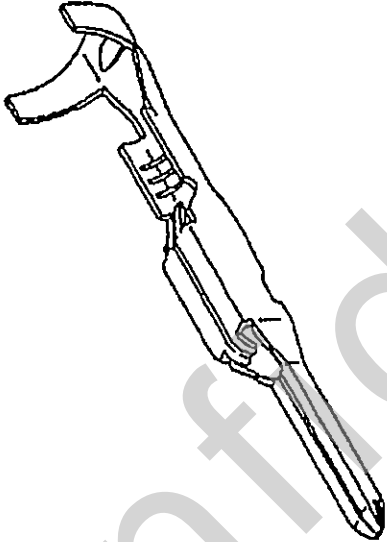
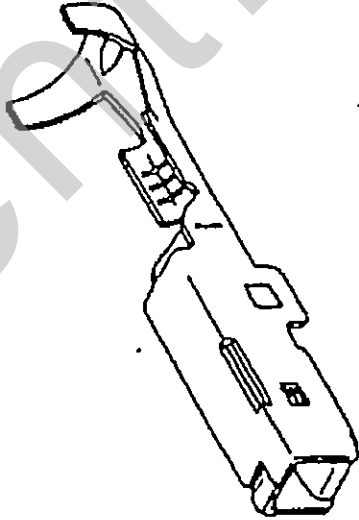
矢崎品番 (矢崎品名)	形状	適用電線サイズ	備考
7114-4102-02 (1.5 SYSTEM CONNECTOR SEALED TERMINAL MALE TIN PLATING) 7114-4102-08 (GOLD PLATING)		0.35 to 0.5 mm ² 22AWG to 20AWG	
7114-4103-02 (1.5 SYSTEM CONNECTOR SEALED TERMINAL MALE TIN PLATING) 7114-4102-08 (GOLD PLATING)		0.75 to 1.25 mm ² 18AWG to 16AWG	
7116-4102-02 (1.5 SYSTEM CONNECTOR SEALED TERMINAL FEMALE TIN PLATING) 7116-4102-08 (GOLD PLATING)		0.35 to 0.5 mm ² 22AWG to 20AWG	
(1.5 SYSTEM CONNECTOR SEALED TERMINAL FEMALE TIN PLATING) 7116-4103-08 (GOLD PLATING)		0.75 to 1.25 mm ² 18AWG to 16AWG	
7116-4105-02 (1.5 SYSTEM CONNECTOR SEALED TERMINAL FEMALE TIN PLATING) *1		1.50 to 2.0 mm ² 14AWG	

*1 次頁参照

※1:本端子は、小さい電線サイズでの過大な電圧降下を抑制することのみの使用として設定しているものです。

本端子の電線にかけられる最大適用電流は、15 Aを越えてはなりません。

最大適用電流は、ベンチテスト結果によってのみ決定されます。

(テスト条件:周囲温度20℃、1.25 mm²電線の単極通電にて20℃上昇した値)。

また、特別な使用条件(周囲温度、極数、電線サイズなど)での使用にあたっては、その条件を考慮した適切な通電電流の設定を行わなければなりません。

タイプ	最大電線サイズ	電圧降下抑制電線サイズ	許容電流 ¹⁾
1.5 システム防水	1.25 mm ² ²⁾	1.5 mm ² 、2.0 mm ² ³⁾	15 A

1) 周囲温度20℃、単極通電(ハウジングなし)、最大電線サイズ(1.25 mm²)で温度上昇20℃

2) 1.25 mm² ≒ 16AWG

3) 2.00 mm² ≒ 14AWG

<付録>

適用電線サイズ

電線サイズ	AWG	22	20	18	16	14
	ISO (mm ²)	0.35	0.5	0.75	1.0	1.5
1.5システム防水端子	MALE	○	○	○	○	○
	FEMALE	○	○	○	○	○

○: 適用

×: 適用外

△: 電圧降下抑制端子

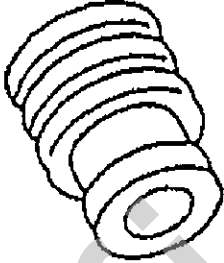
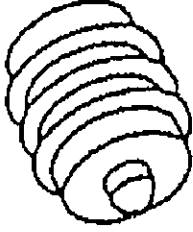
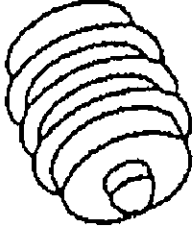
矢崎品番 (矢崎品名)	形状	適用電線サイズ	備考
7158-3030-50 (1.5 SYSTEM SEALED CONNECTOR DUMMY PLUG)		Φ 1.20 to 1.70	COLOR: RED
7158-3031-90 (1.5 SYSTEM SEALED CONNECTOR DUMMY PLUG)		Φ 1.63 to 2.20	COLOR: BLUE
7158-3032-60 (1.5 SYSTEM SEALED CONNECTOR DUMMY PLUG)			COLOR: GREEN

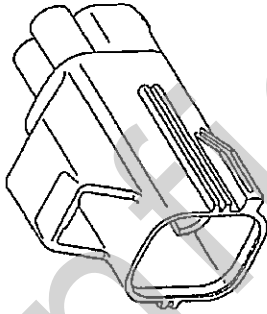
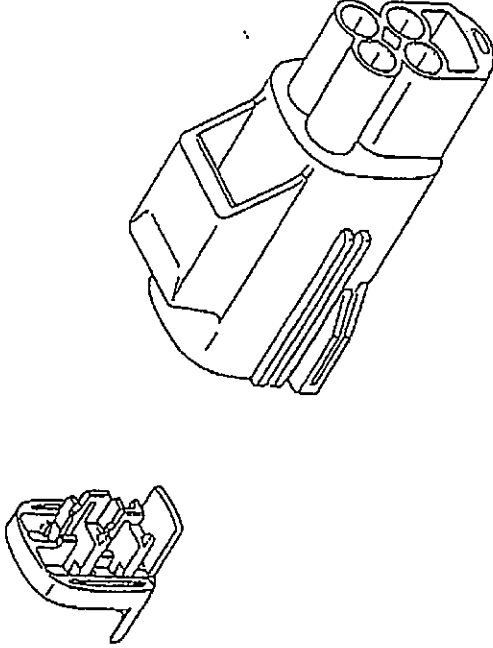
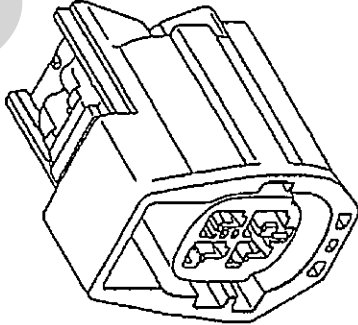
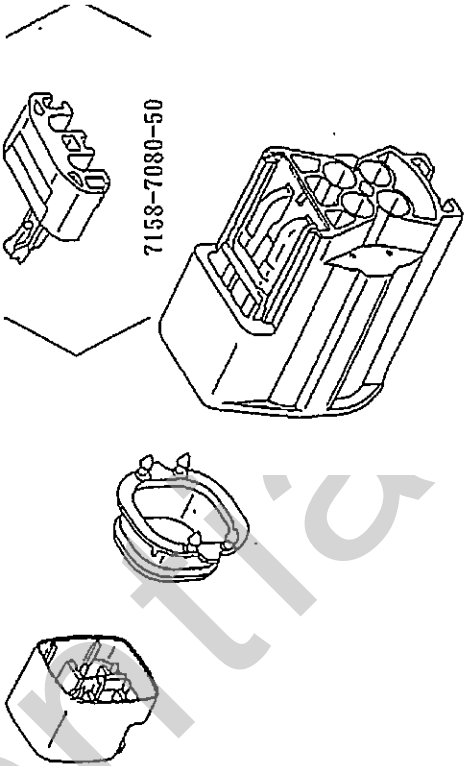
矢崎品番 (矢崎品名)	形状	構成 (品番と形状)
<p>7282-5543-10 (1.5 SYSTEM SEALED CONNECTOR 4P MALE) (TYPE-A)</p>		
<p>7283-5543-10 (1.5 SYSTEM SEALED CONNECTOR 4P FEMALE) (TYPE-A)</p> <p>7283-5544-10 (with CPA)</p>		

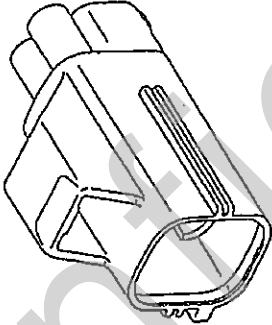
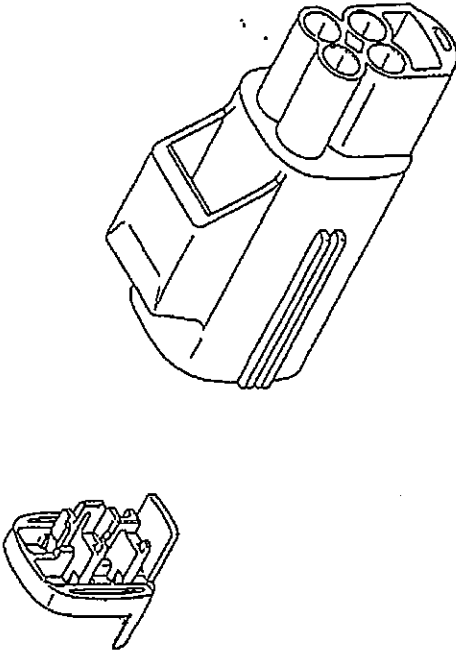
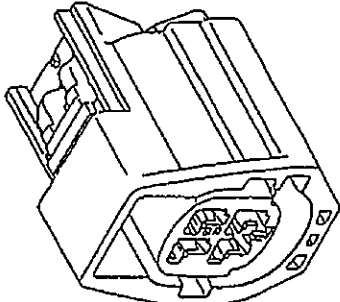
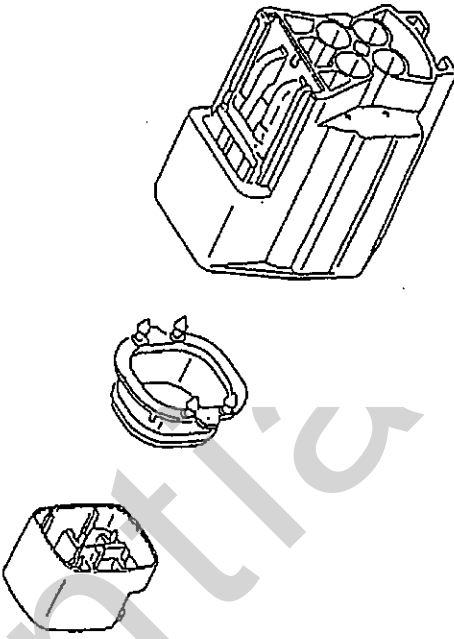
矢崎品番 (矢崎品名)	形状	構成(品番と形状)
<p>7282-5889-30 (1.5 SYSTEM SEALED CONNECTOR 4P MALE) (TYPE-B)</p>		
<p>7283-5889-30 (1.5 SYSTEM SEALED CONNECTOR 4P FEMALE) (TYPE-B)</p>		

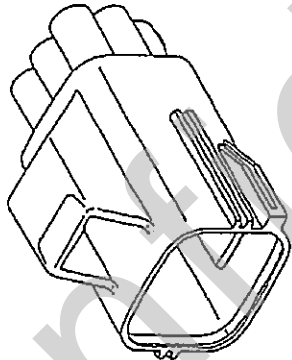
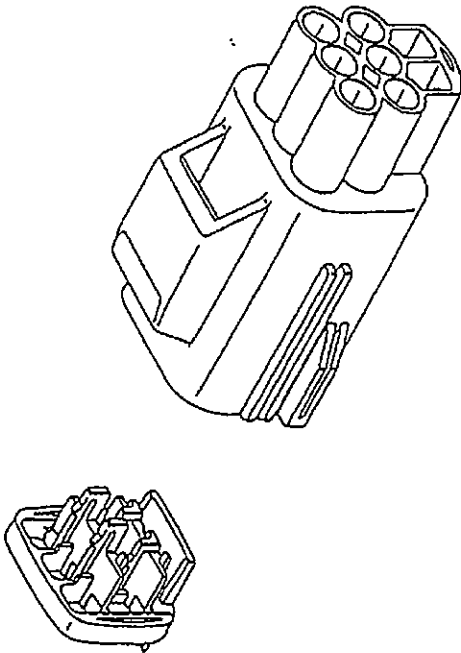
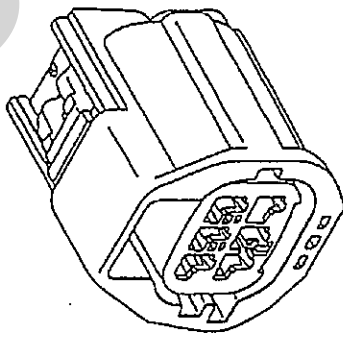
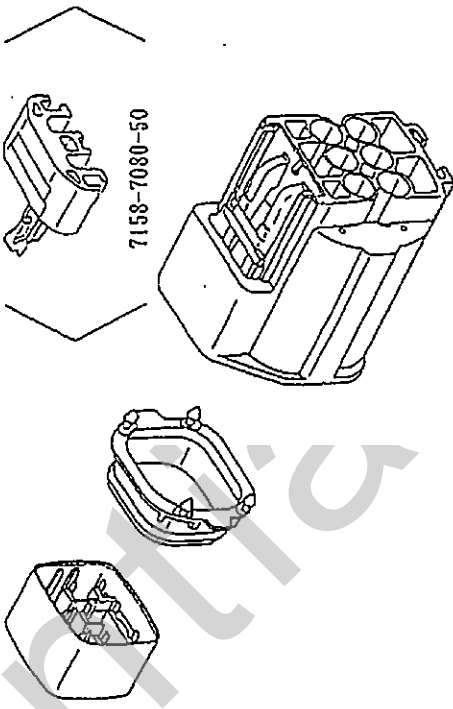
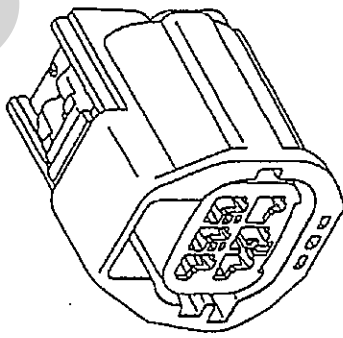
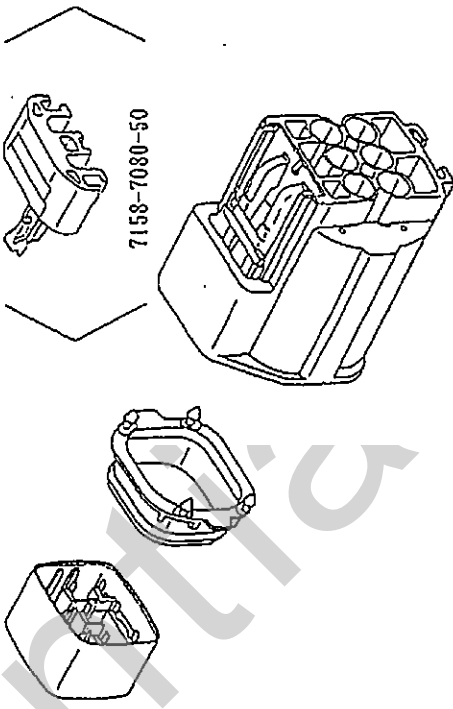
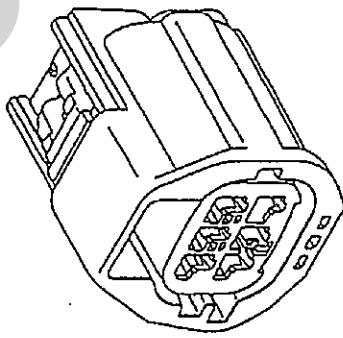
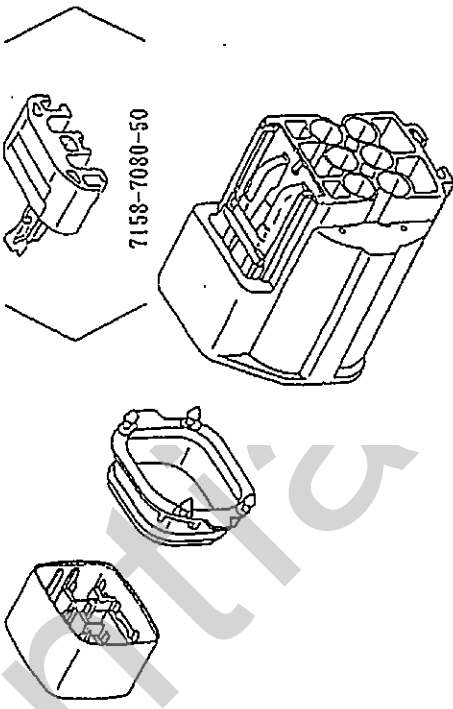
矢崎品番 (矢崎品名)	形状	構成(品番と形状)
7282-5553-10 (1.5 SYSTEM SEALED CONNECTOR 6P MALE)		
7282-5553-30 (1.5 SYSTEM SEALED CONNECTOR 6P MALE)		
7283-5553-10 7283-5553-30 (1.5 SYSTEM SEALED CONNECTOR 6P FEMALE)		
7283-5554-10 7283-5554-30 (1.5 SYSTEM SEALED CONNECTOR 6P FEMALE) (with CPA)		

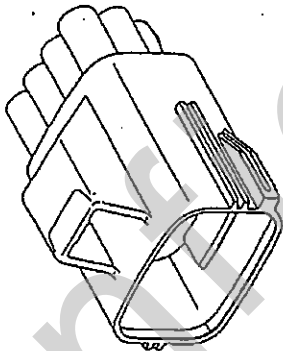
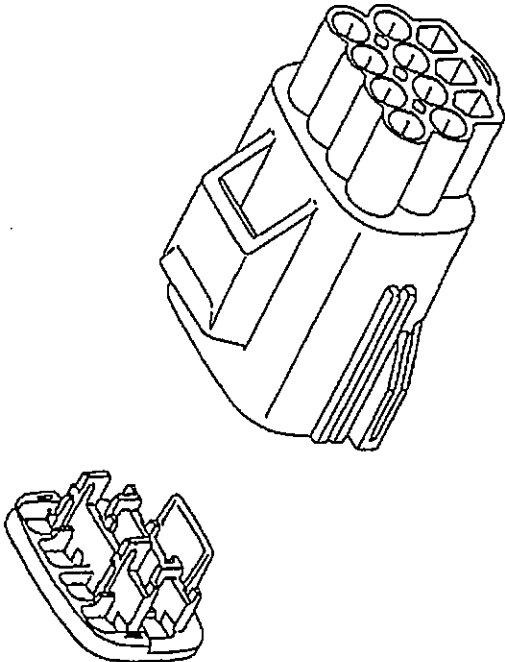
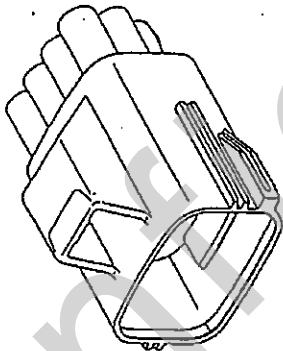
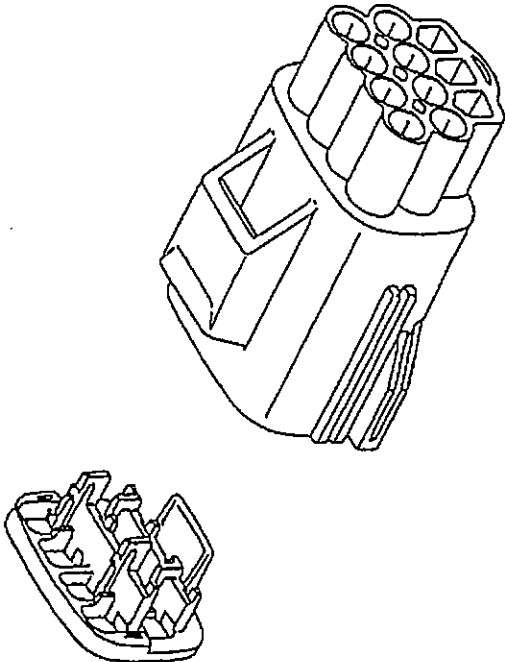
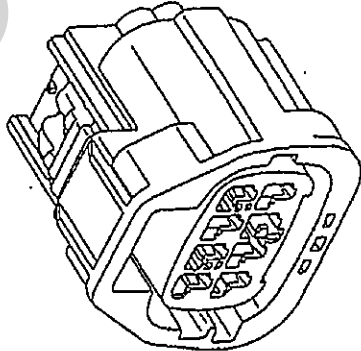
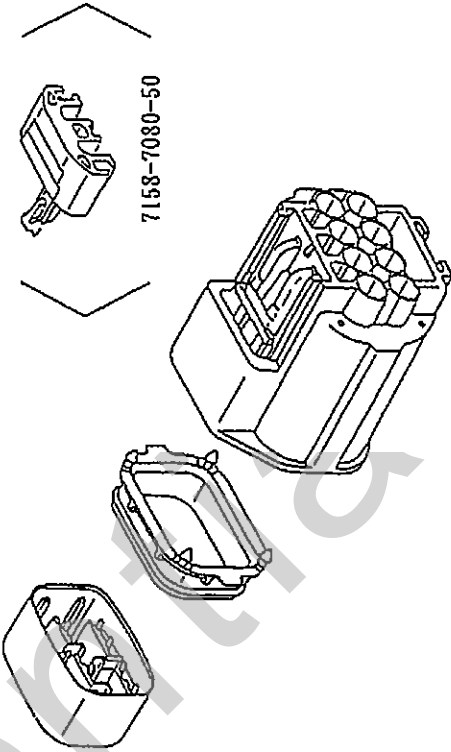
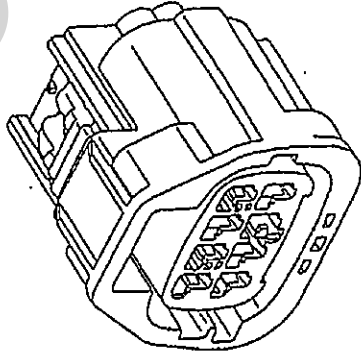
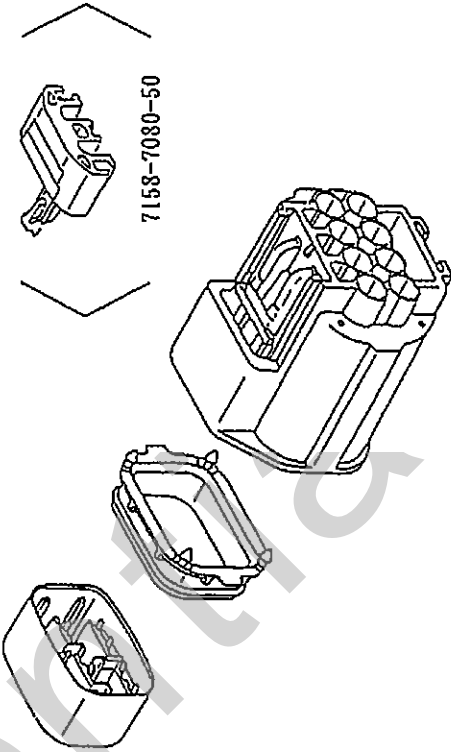
矢崎品番 (矢崎品名)	形状	構成(品番と形状)
7282-5684-10 (1.5 SYSTEM SEALED CONNECTOR 8P MALE)		
7282-5684-30 (1.5 SYSTEM SEALED CONNECTOR 8P MALE)		
7283-5684-10 7283-5684-30 (1.5 SYSTEM SEALED CONNECTOR 8P FEMALE)		
7283-5685-10 7283-5685-30 (1.5 SYSTEM SEALED CONNECTOR 8P FEMALE) (with CPA)		

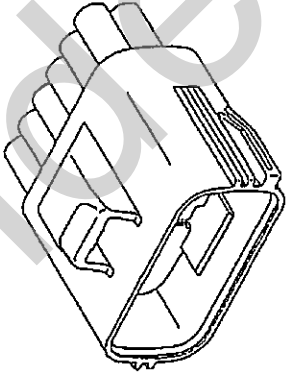
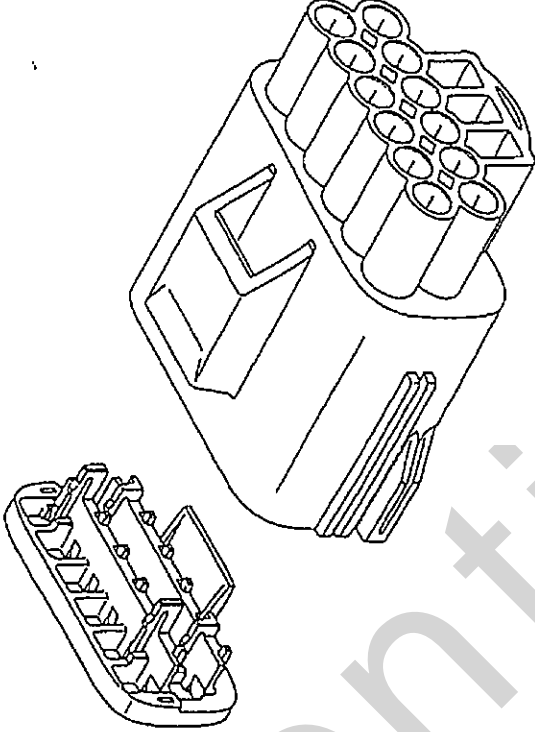
矢崎品番 (矢崎品名)	形状	構成(品番と形状)
<p>7282-5545-10 (1.5 SYSTEM SEALED CONNECTOR 12P MALE)</p>		
<p>7282-5545-30 (1.5 SYSTEM SEALED CONNECTOR 12P MALE)</p>		

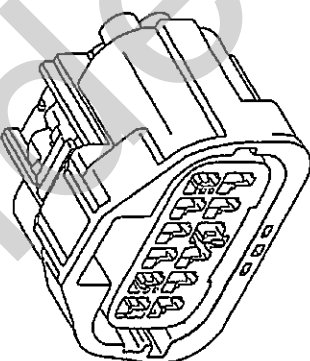
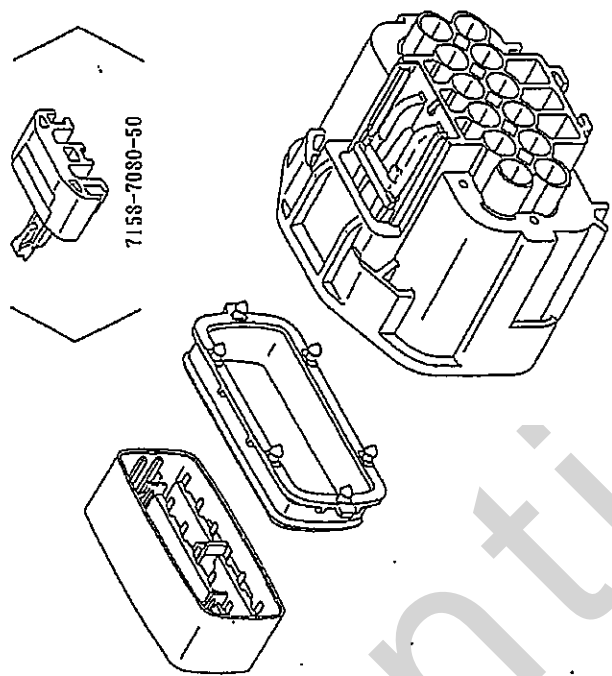
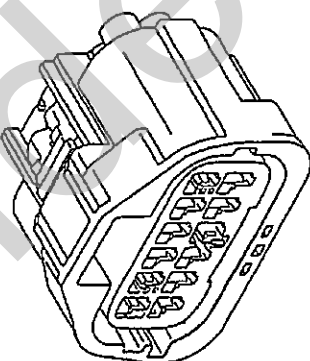
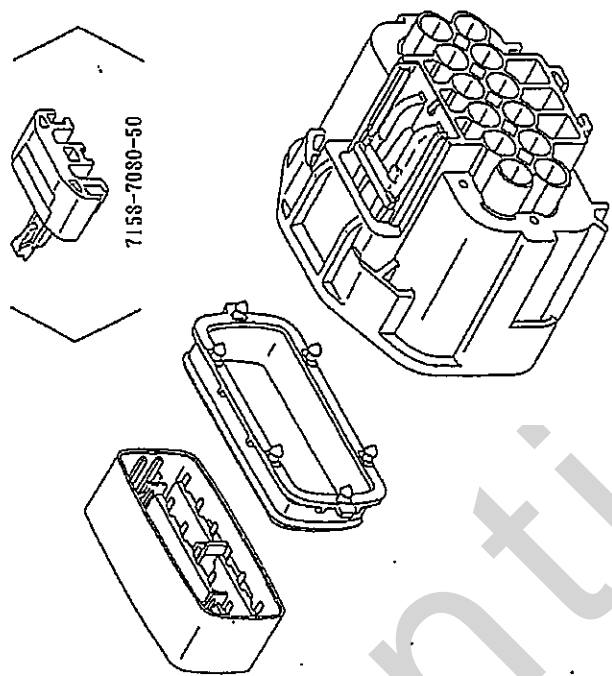
矢崎品番 (矢崎品名)	形状	構成(品番と形状)
<p>7283-5545-10 7283-5545-30 (1.5 SYSTEM SEALED CONNECTOR 12P MALE)</p>		 <p>7158-7080-50</p>
<p>7283-5546-10 7283-5546-30 (1.5 SYSTEM SEALED CONNECTOR 12P FEMALE) (with CPA)</p>		 <p>7158-7080-50</p>

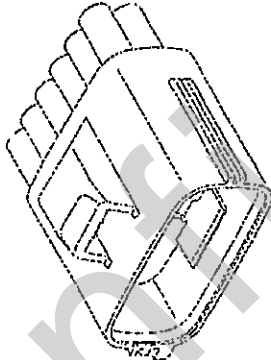
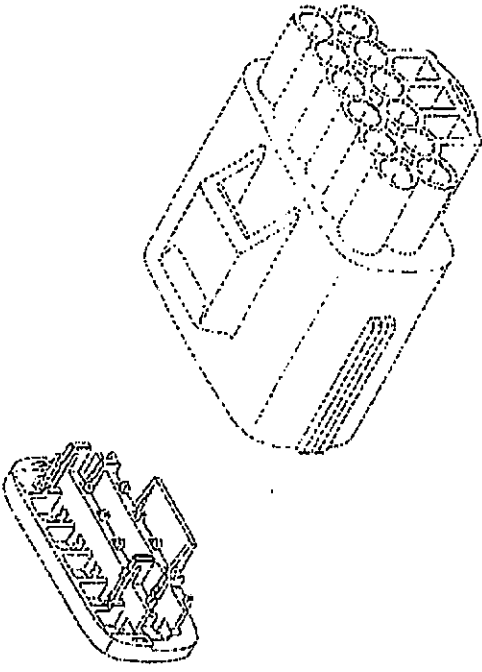
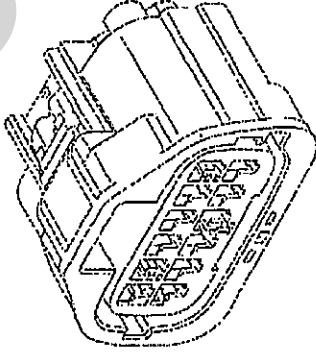
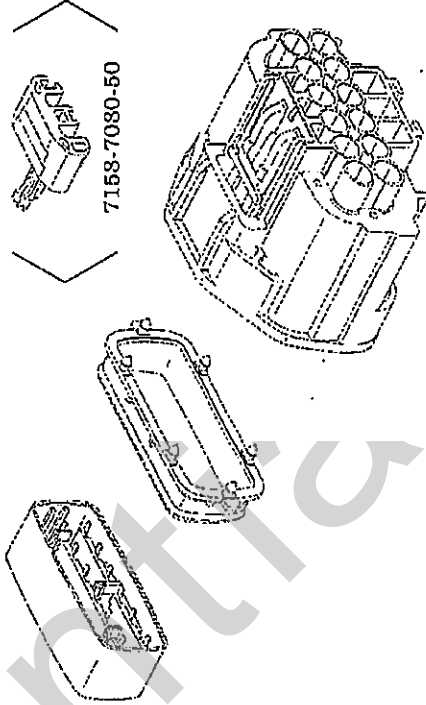
矢崎品番 (矢崎品名)	形状	構成 (品番と形状)
<p>7282-5968-40 (1.5 SYSTEM SEALED CONNECTOR 12P MALE) (TYPE-B)</p>		
<p>7283-5968-40 (1.5 SYSTEM SEALED CONNECTOR 12P FEMALE) (TYPE-B)</p> <p>7283-5969-40 (with CPA)</p>		

YPES-15-298E

Handling Manual
For
YESC 1.5 System Sealed

Note:

This Handling Manual is subject to change without any prior notice.

YAZAKI Corporation
YAZAKI Parts Co., Ltd.
26th Oct. 2016

Table of Contents

1. Description of Parts Features and Functions	P. 3
1-1. Male Terminal Features and Functions	P. 3
1-2. Female Terminal Features and Functions	P. 4
1-3. Male Housing Features and Functions	P. 5
1-4. Female Housing Features and Functions	P. 6
2. Parts Storage, Transportation and Handling Precautions	P. 7
2-1. Terminals	P. 7
1) Transportation	P. 7
2) Storage	P. 8
2-2. Housings etc.	P. 8
3. Terminal Crimping Specifications	P. 9
3-1. Crimping Standards	P. 9
3-2. Crimping Process Check Points and Judgement Criteria	P. 9
3-3. Measurement Points of Specified Crimp Dimensions	P. 13
3-4. Method for Measurement of Crimp Height and Crimp Width	P. 13
3-5. Measurement Equipment	P. 14
3-6 <i>Measurement of Bend Up/Down</i>	P. 15
4. Handling Recommendation for Terminated Wires	P. 16
5. Terminal and Front Holder Setting Instructions and Precautions	P. 17
5-1. Male/Female Terminal Installation to Housing	P. 17
5-2. Male Front Holder Setting on Male Housing	P. 18
1) Male Front Holder Function	P. 19
5-3. Female Front Holder Setting on Female Housing	P. 20
1) Female Front Holder Function	P. 21
6. Terminal and Front Holder Removal Instructions and Precautions	P. 22
6-1. Disengagement of Front Holder from Full-Lock Position, Male	P. 22
6-2. Disengagement of Front Holder from Full-Lock Position, Female	P. 23
6-3. Terminal Removal	P. 24
6-4. Male Front Holder Removal & Insertion Tool Shape	P. 27
6-5. Terminal Removal Tool Shape	P. 27
7. Dummy Plug Setting and Removal Instructions and Precautions	P. 28
7-1. Dummy Plug Setting	P. 28
7-2. Dummy Plug Removal	P. 28

8. Connector Position Assurance (CPA) Function P.29
8-1. How to Lock the CPA P.29
8-2. How to Unlock the CPA P.30

9. Precautions During Wire Harness Assembly P.31
9-1. Wire Harness Assembly P.31
9-2. Taping P.31
9-3. Inspection P.32

10. Notice for Packing of Wire Harness P.33

11. Precautions During Wire Harness Installation into the Vehicle P.35
11-1. Connector Mating P.35
11-2. Connector Servicing P.36

© Connector Configurations and Figures of Part Numbers ATTACHED P.1 ~ 11

Confidential

1. Description of Parts Features and Functions
 -1. Male Terminal Features and Functions

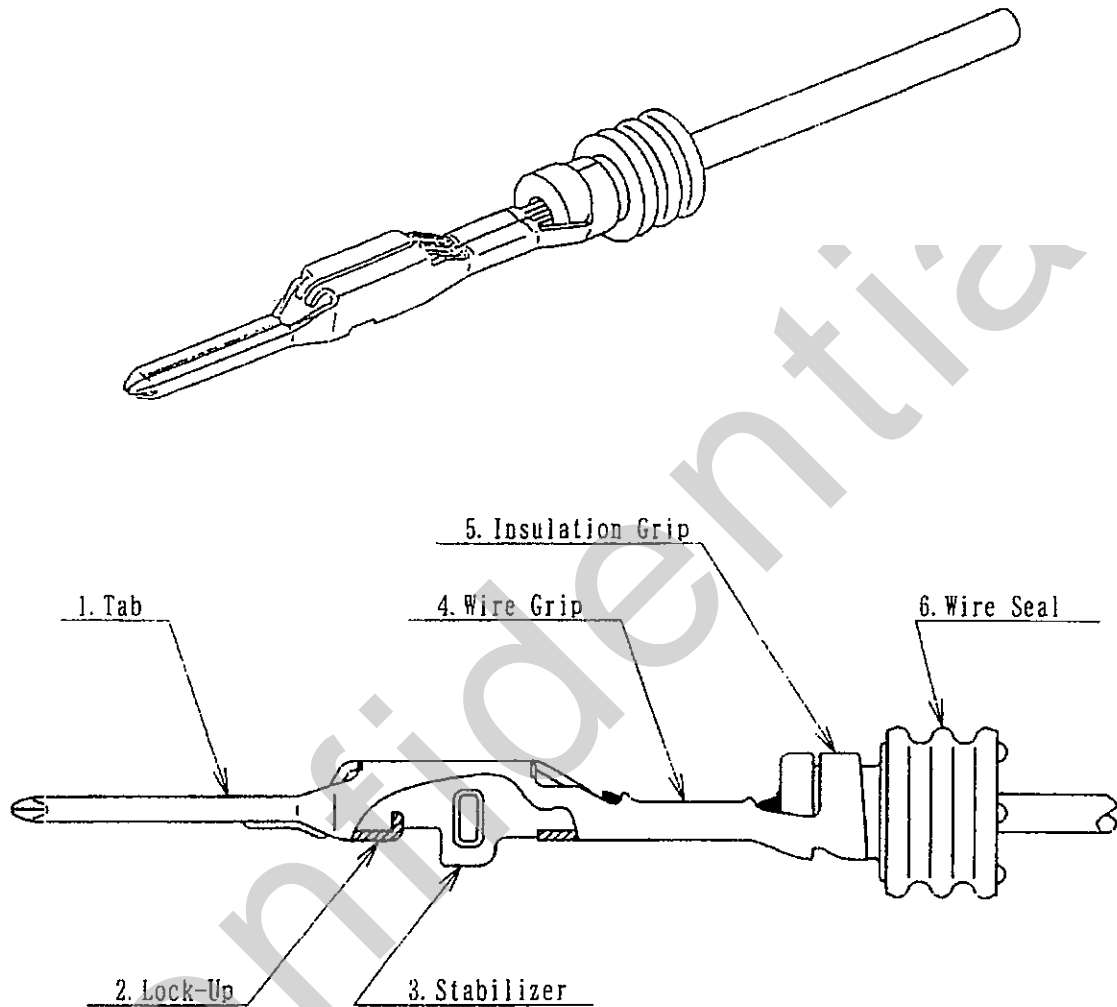

No.	Feature Name	F u n c t i o n
1	Tab	Contact with Female Terminal
2	Lock-Up	Provide Surface for Lock-up With Terminal Cavity Lock-arm
3	Stabilizer	Prevent Terminal reverted Insertion
4	Wire Grip	Conductor Crimping
5	Insulation Grip	Insulation Crimping
6	Wire Seal	Seal between Wire and Housing

1-2. Female Terminal Features and Functions

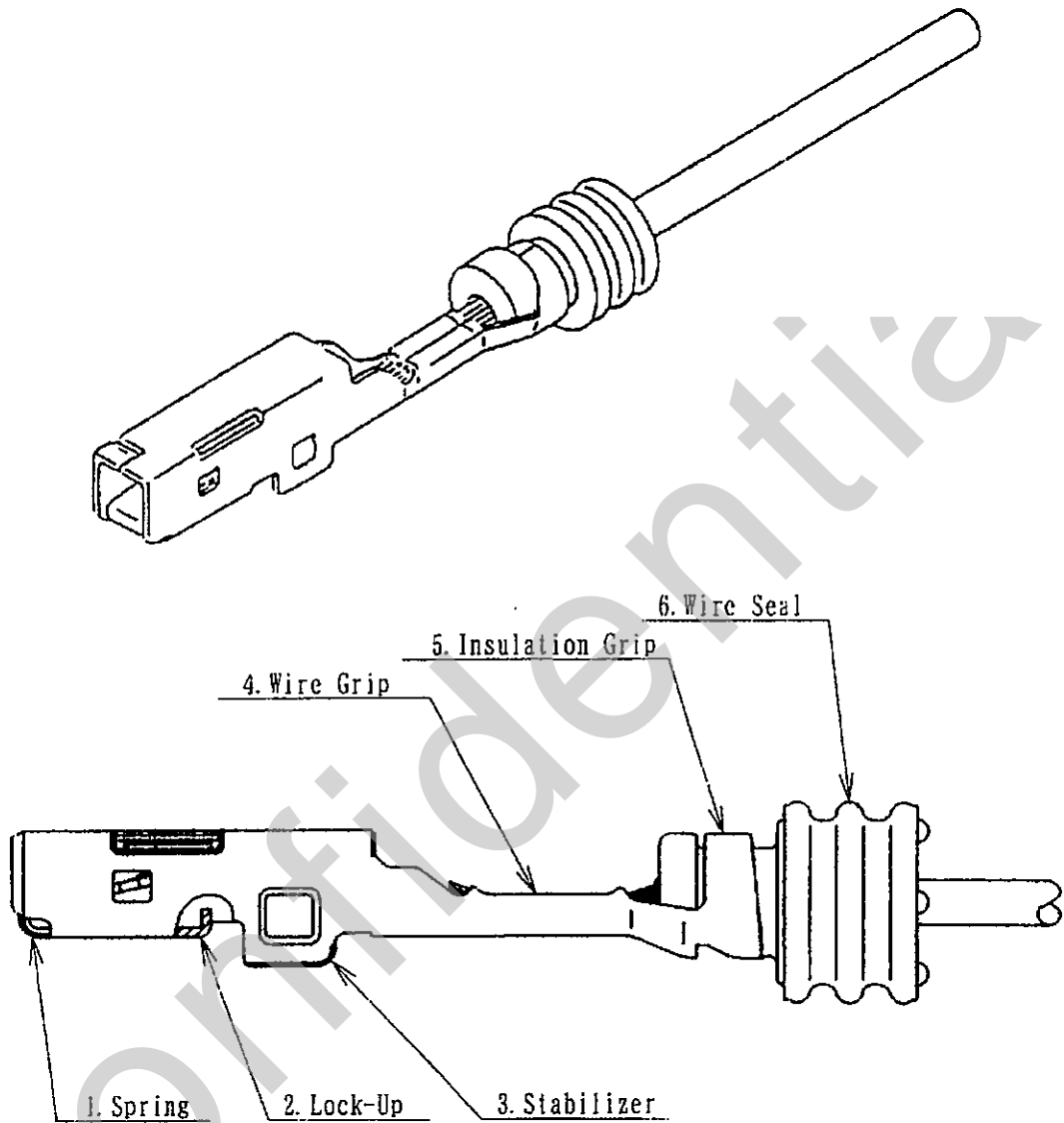

Nc.	Feature Name	F u n c t i o n
1	Spring	Contact with Male Terminal
2	Lock-Up	Provide Surface for Lock-up With Terminal Cavity Lock-arm
3	Stabilizer	Prevent Terminal reverted Insertion
4	Wire Grip	Conductor Crimping
5	Insulation Grip	Insulation Crimping
6	Wire Seal	Seal between Wire and Housing

1-3. Male Housing Features and Functions

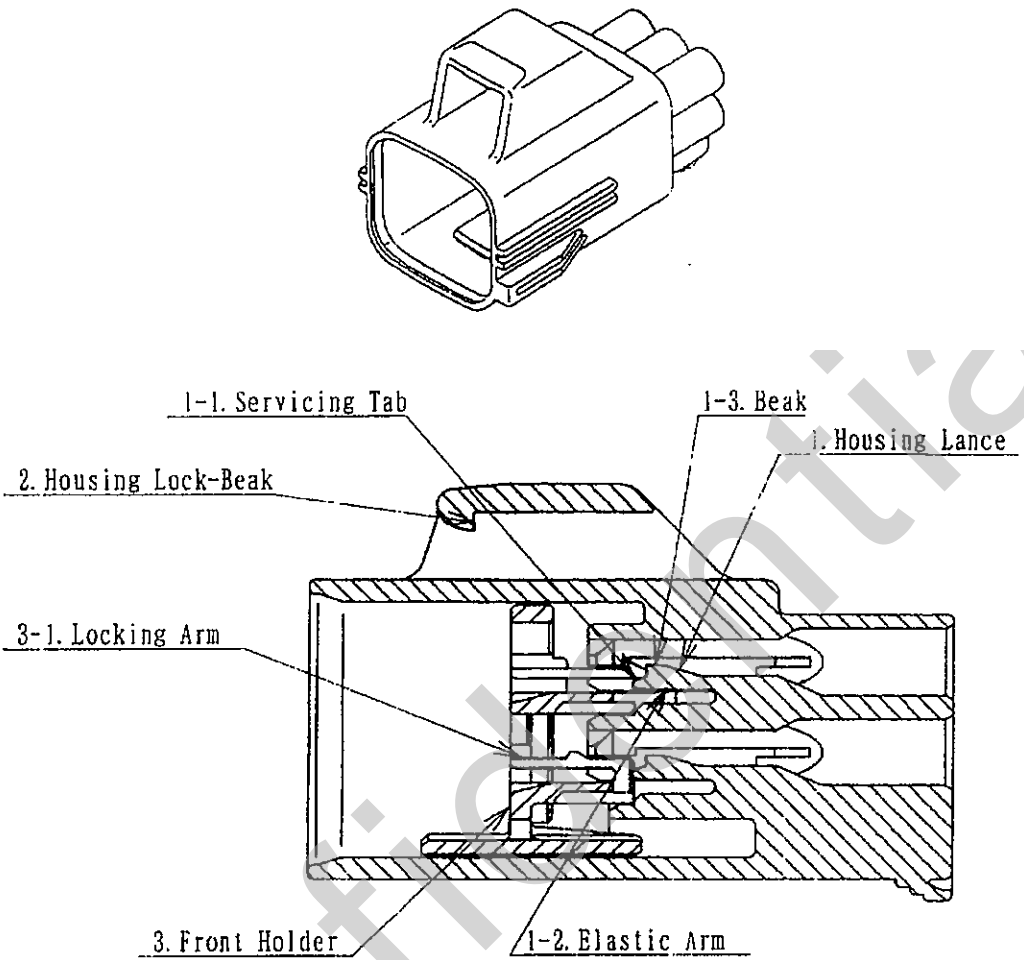

NO.	Feature Name	Function	
1	Housing Lance	Snap-fit Feature for Male Terminal	
	1-1	Servicing Tab	Release of Housing Lance
	1-2	Elastic Arm	Allow Movement of Beak
	1-3	Beak	Lock/Retention of Male Terminal
2	Housing Lock-Beak	Lock/Retention of Female Housing	
3	Front Holder	Terminal Position Assurance	
	3-1	Locking Arm	Setting and Releasing of Front Holder

1-4. Female Housing Features and Functions

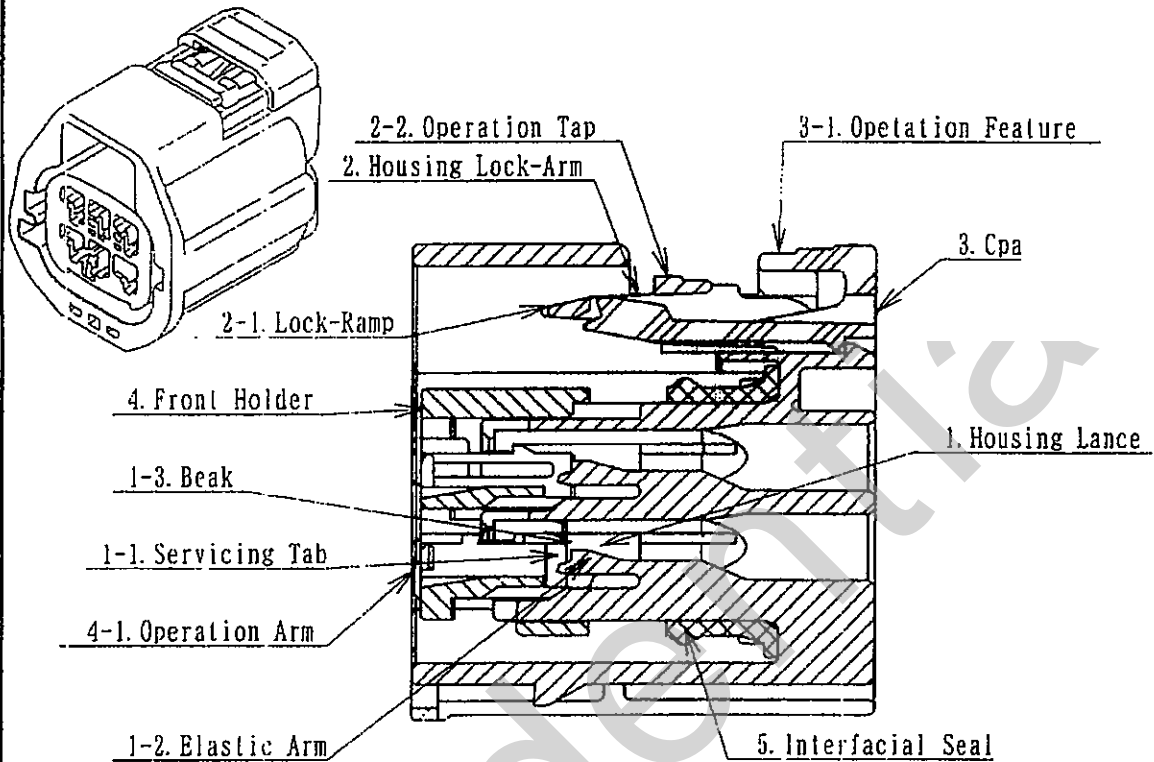

NO.	Feature Name	Function
1	Housing Lance	Snap-fit Feature for Female Terminal
	1-1 Servicing Tab	Release of Housing Lance
	1-2 Elastic Arm	Allow Movement of Beak
	1-3 Beak	Locking/Retention of Female Terminal
2	Housing Lock-Arm	Lock with Male Housing
	2-1 Lock-Ramp	Lock/Retention of Male Housing
	2-2 Operation Tap	Release of Housing Lock for Service
3	Cpa (Connector Position Assurance)	Housing Full-Male Detection
	3-1 Operation Feature	Operation of Cpa
4	Front Holder	Terminal Position Assurance
	4-1 Operation Arm	Setting and Releasing of Front Holder
5	Interfacial Seal	Sealing Between Mated Housings

2. Parts Storage, Transportation and Handling Precautions

The parts must be free of deformation, damage, etc. during storage and transportation.

2-1. Terminals

- Partial terminal reels should have the carrier strip secured to prevent reel unwinding of terminal entanglement. Recommended method is shown below.
- Recommended storage and transportation of terminal reels is shown below.

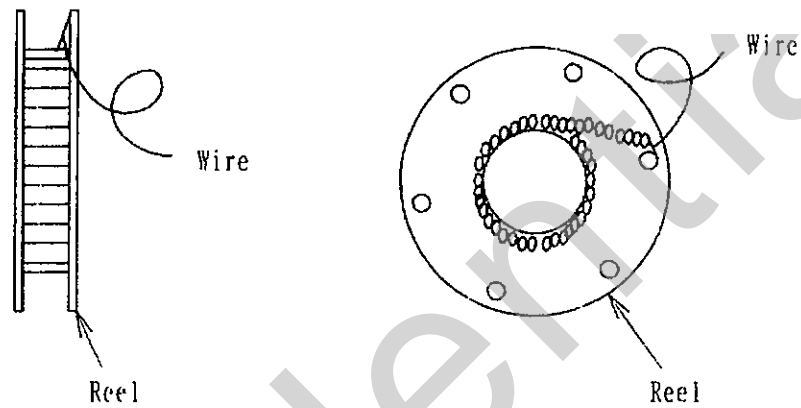

) Transportation

- Reels should be packed (protected) to avoid any harsh impacts during transportation.
- Care should be taken to avoid any harsh impacts by dropping from high position.
- When carrying reels out of a box, take extra care not to break the reels because it is made of paper.

Recommended Method

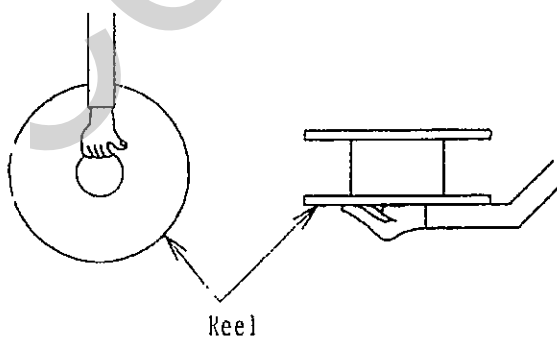

Poor Practice

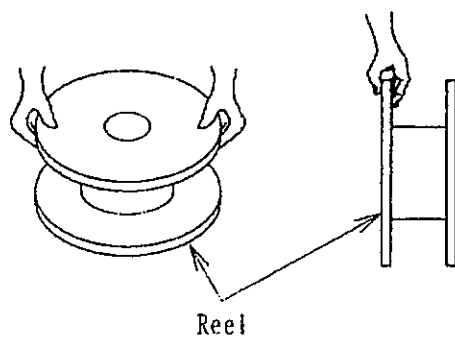

2) Storage

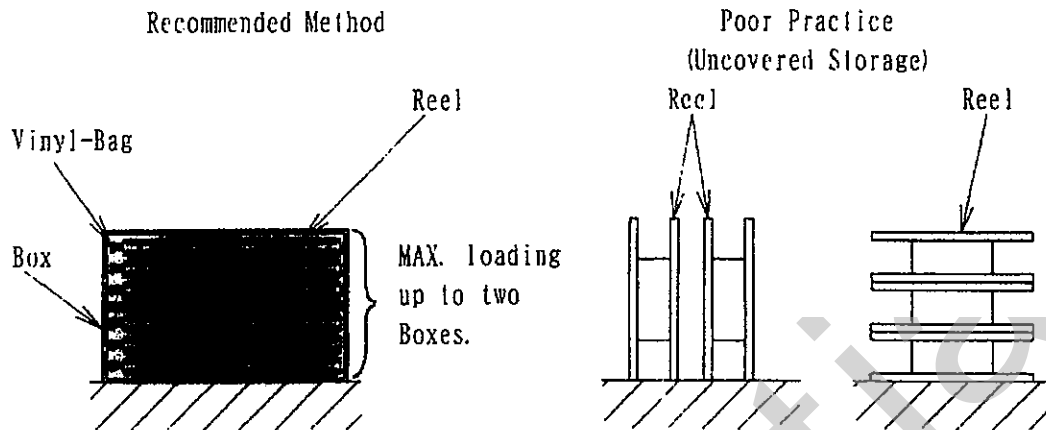

2-2. Housings etc.

- Parts should be stored in the box or plastic bag in which they were shipped.
- Parts should be stored indoors, away from direct sunlight.
- Parts should be stored in an area void of excess humidity.
- Parts must not be stored in an uncovered or unprotected condition.
(i.e., parts should be protected from water, oil, dust, etc.)
- Care should be taken to avoid any harsh impacts on the part containers during transportation.
- Care should be taken to avoid any harsh impacts by dropping from high position.

3. Terminal Crimping Specifications

3-1. Crimping Standards



Contact our sales department for the official crimping standard.



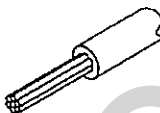
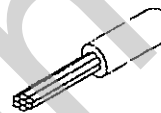
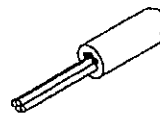
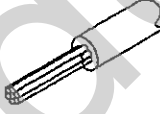
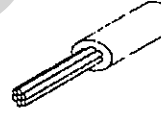
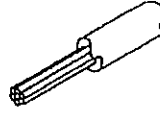
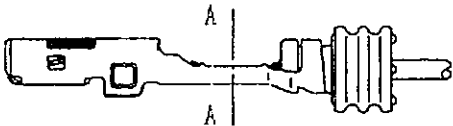
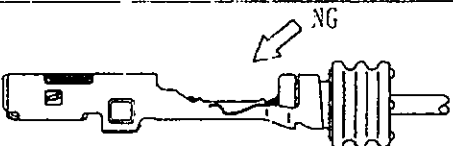
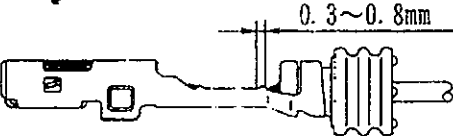
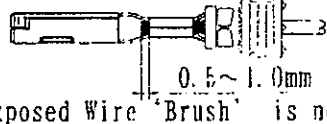
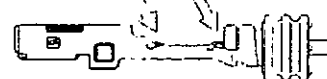

- <NOTE> - Pay attention to crimp within the limit on the crimping standard. If it is out of the standard, because retention force of the crimping area and electrical resistance are not satisfied, the function of the part may be affected
- The above is limited to the case when Yazaki's crimping tool is used.

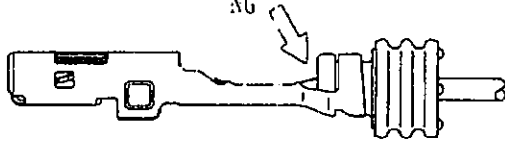
3-2. Crimping Process Check Points and Judgement Criteria

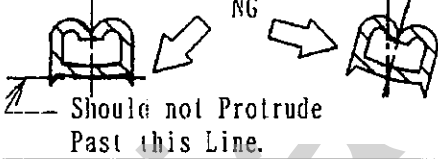
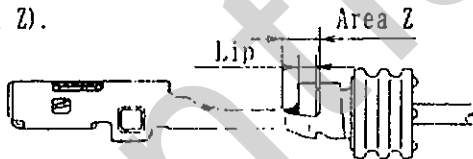
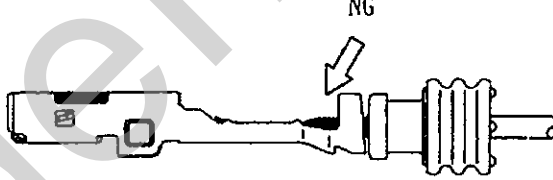
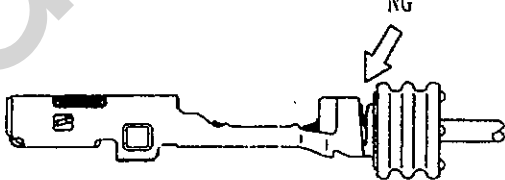
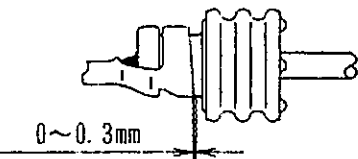
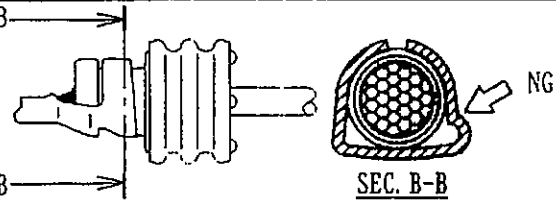
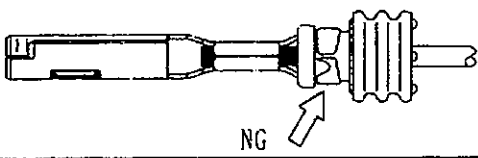
During the crimping process care must be taken to assure the following items are correct.

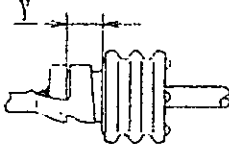
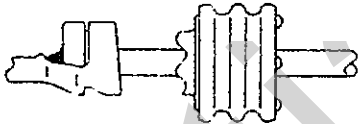
ITEM	CHECK POINT	JUDGEMENTS
Insul. Stripping	- Conductor Diagonal Cutting	 Normal  Conductor Diagonal Cut  Conductor Cut
	- Conductor Cut	
	- Any Flaw on Conductors	 Conductor Flaw  Insulation Diagonal Cut  Insulation Damaged
	- Insulation Diagonal Cut	
	- Any Damage on Insulation	
Crimping of Conductor Grip Male/Female	Normal Crimping Condition	
	Any Conductor Flaw	
	Bell-Mouth	
	Top Length of Conductor	 <p>Exposed Wire "Brush" is not Acceptable.</p> 

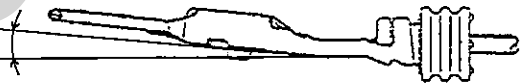
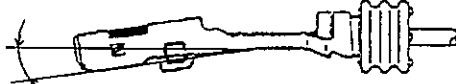
ITEM	CHECK POINT	JUDGEMENTS
Crimping of Conductor Grip Male/Female	Insulation Crimped by Conductor Grip	
	Burr and/or Twist	<p>Normal</p>  <p>SEC. A-A</p>  <p>Should not Protrude Past this Line.</p>
Crimping of Insulation Grip Male/Female	Normal Crimping Condition	<p>The end of insulation and wire seal must be seen between wire grip and insulation grip (Area Z).</p> 
	Wire Seal Falls short of Insulation Grip	
	Any flaw regarding Wire seal	
	Cut off Length	<p>Cut-off length no damage to wire seal</p>  <p>0~0.3mm</p>
	No Crease of Grip	 <p>SEC. B-B</p>
	Sliced Wire Seal Insulation Crimp Cuts Into Wire Seal When Crimped	

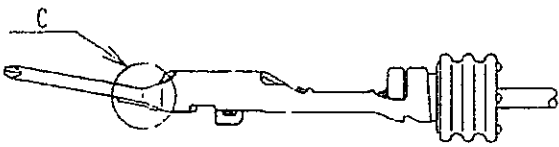
ITEM	CHECK POINT	JUDGEMENTS
Crimping of Insulation Grip Male/Female	Wire Seal Position	<p>The insulation grip must fall between sealing rib and attachment lip (Area Y).</p> 
	Wire Seal Scratch or Cut	<p>Scratch or cut on wire seal is not acceptable.</p> 
Crimp Discrepancy Deformed by Crimping Male/Female	Twist	<p>Twisted terminals should be rejected during visual checking.</p> 
	Bend Up	<p>MAX. 1°</p>  <p>MAX. 1°</p>  <p>The bend up angle should be 1° or less.</p>
		<p>MAX. 3°</p>  <p>MAX. 3°</p>  <p>The bend down angle should be 3° or less.</p>
	Tab Deformation Male Only	<p>Deformation at point C is not acceptable.</p> 

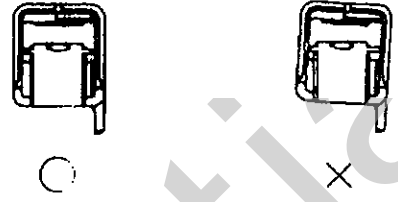
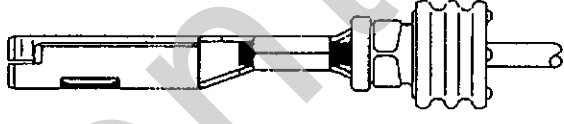
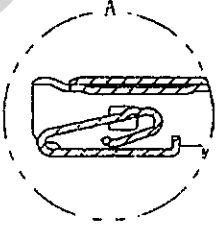
ITEM	CHECK POINT	JUDGEMENTS
Crimp Discrepancy Deformed by Crimping Male/Female	Crimp Discrepancy	
Deformed by Crimping Male/Female	Box Misalignment Female Only	
	Defect of Terminal Feeding	
Terminal Deformation Female Only	Terminal Deformation at A	<p data-bbox="726 1030 1316 1064">Terminal deformation at A is not acceptable.</p> 

3-3. Measurement Points of Specified Crimp Dimensions

The optimum crimp dimensions should be as close to nominal as possible.

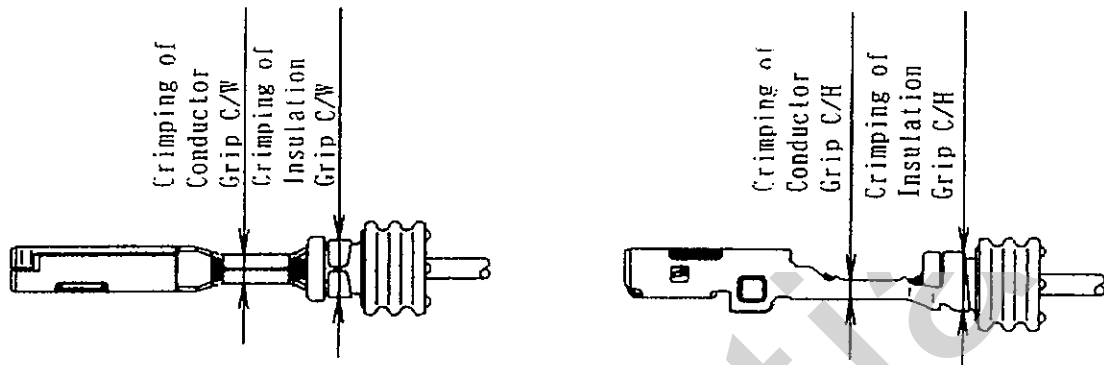

C/H should not be measured at this point

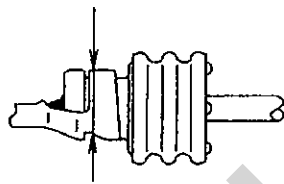

3-4. Method for Measurement of Crimp Height and Crimp Width

Conductor crimp : C/H and C/W should be measured at the center of the crimp using a micrometer.

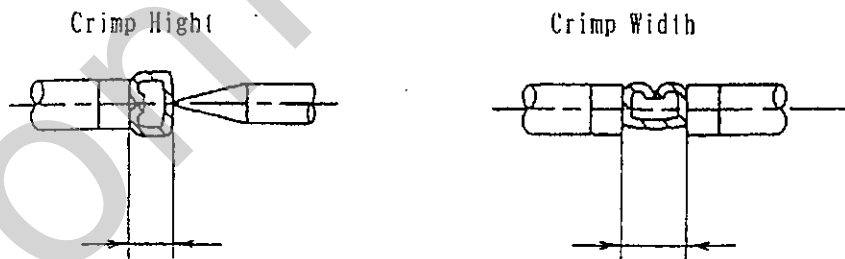

Insulation crimp : C/H and C/W should be measured at the center of the crimp using a micrometer.

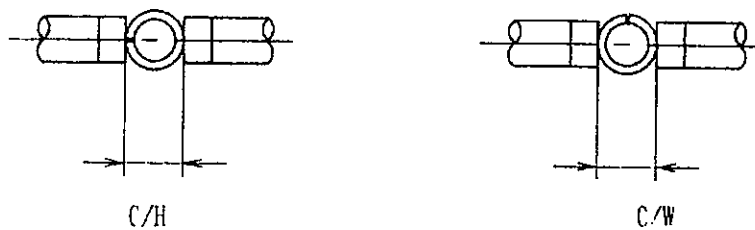

3-5. Measurement Equipment

The micrometer used for measurement should be similar to the device shown below. In order to obtain the most accurate measurement possible, it is recommended that the micrometer is mounted on a stand during use.

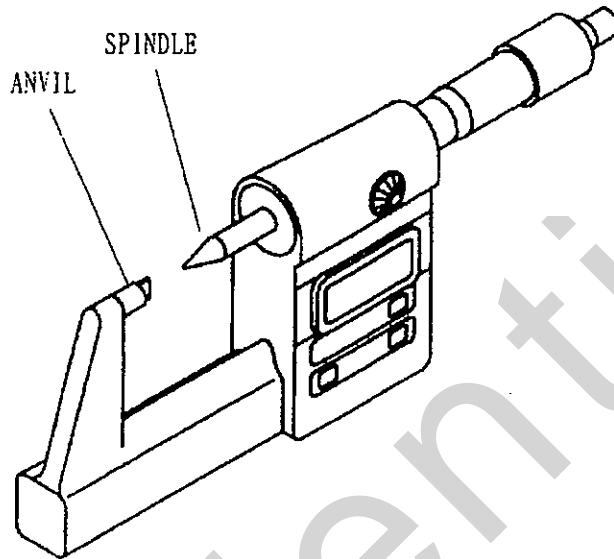

ANVIL

SPINDLE A

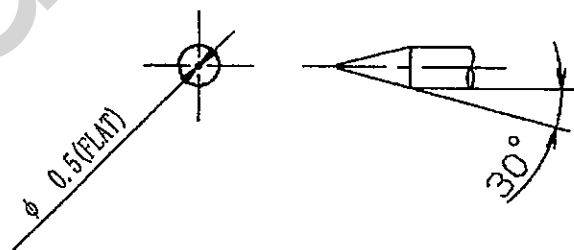
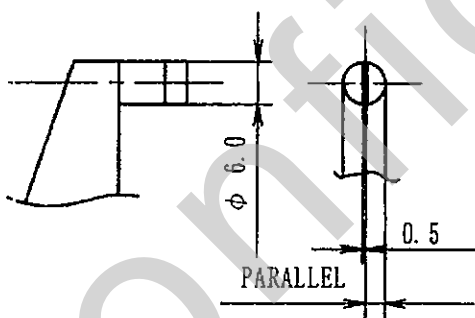



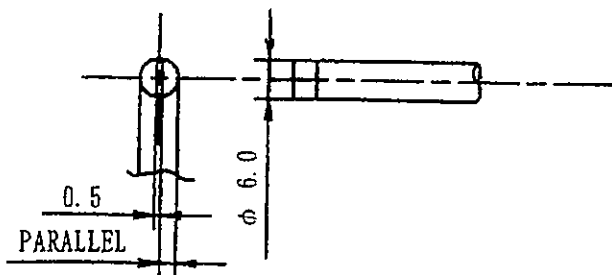

SPINDLE B

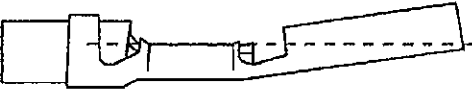
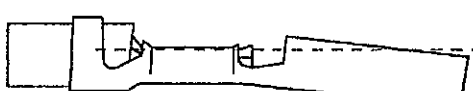
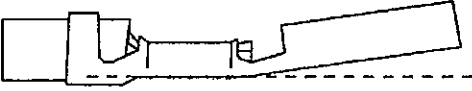

Use spindle A for the C/H measurement of conductor crimp.

Use spindle B for the C/W measurement of conductor crimp and for C/H and C/W measurement of Insulation crimp.

3-6 Measurement of Bend Up / Down

Step	Bend Up	Bend Down
1	 <p data-bbox="288 584 818 651">Set the sample, and define the upper flat face of the conductor crimp as a reference line.</p>	 <p data-bbox="874 584 1404 651">Set the sample, and define the upper flat face of the conductor crimp as a reference line.</p>
2	 <p data-bbox="288 808 818 898">Move the reference line horizontally downward to place it at the base portion of the conductor crimp-box transition area.</p>	 <p data-bbox="874 808 1404 898">Move the reference line horizontally downward to place it at the base portion of the conductor crimp-box transition area.</p>
3	 <p data-bbox="288 1032 818 1099">Measure the angle of the bottom face of the box with reference to the reference line.</p>	 <p data-bbox="874 1032 1404 1099">Measure the angle of the bottom face of the box with reference to the reference line.</p>
Male TM	 <p data-bbox="456 1256 1145 1290">For male terminal, measure the angle of the bottom face of</p>	

4. Handling Recommendation for Terminated Wires

Following care must be taken when handling terminated wires so as not to deform (i. e. :bending, deformation) during transportation.

- Terminated wires should be prepared only for subsequent usage rather than for stock/storage because terminated wires before installation into housings are easily broken.
- The number of terminals crimped per wire bundle should range from 50-100 pieces. Bundles should be bound with elastic bands to prevent separation. (If bundled wires are more than 100 pieces, wires may be entangled each other or wiring becomes difficult because of self-weight of the wires. See below.)
- Terminated leads should be covered with protective cover after rapped with vinyl bags to protect the crimped terminals. This bag should not be removed or opened until the leads is included in the harness assembly operation. See below.
- Terminated wires should be transported by using a wire hanging stand or a covered carton/container. Do not pile up the terminated wires. (Pay attention to use the best method for the wires and terminals not to damage them.)
- If the terminated wires must be transported to another facility for assembly, leads should be carefully placed in a covered carton/container. The container should be handled with care in order to avoid damage to crimped terminals.
- During shipping, damage may occur to the wire seal. Assembly workers should check the wire seal for nicks or cuts before usage.

Example for Handling of Terminated Leads

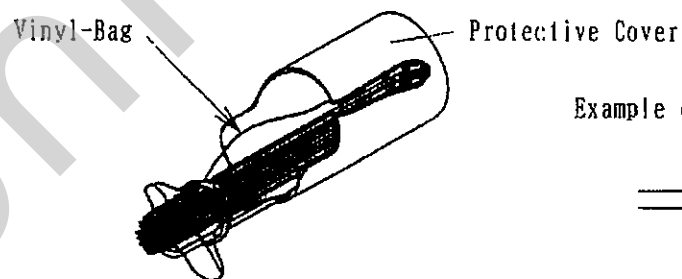

Example of Wire Hanging

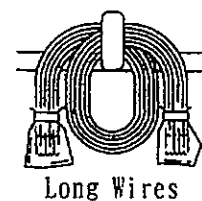
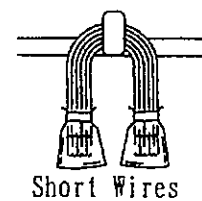
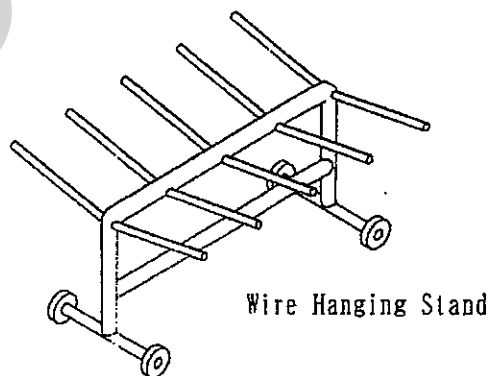

5. Terminal and Front Holder Setting Instructions and Precautions

5-1. Male/Female Terminal Installation to Housing

- After assuring the orientation of the male/female terminals is correct, push the terminal into the appropriate cavity of the male/female housing. (The front holder must be in the pre-set position for terminal insertion to occur.)
- Insert the terminal until an audible 'click' sound is heard.
- After inserting the terminal, pull the wire lightly to confirm whether the terminal is surely locked.
- Confirm the rear end of wire seal crimped with terminal is inside the terminal entrance of the housing

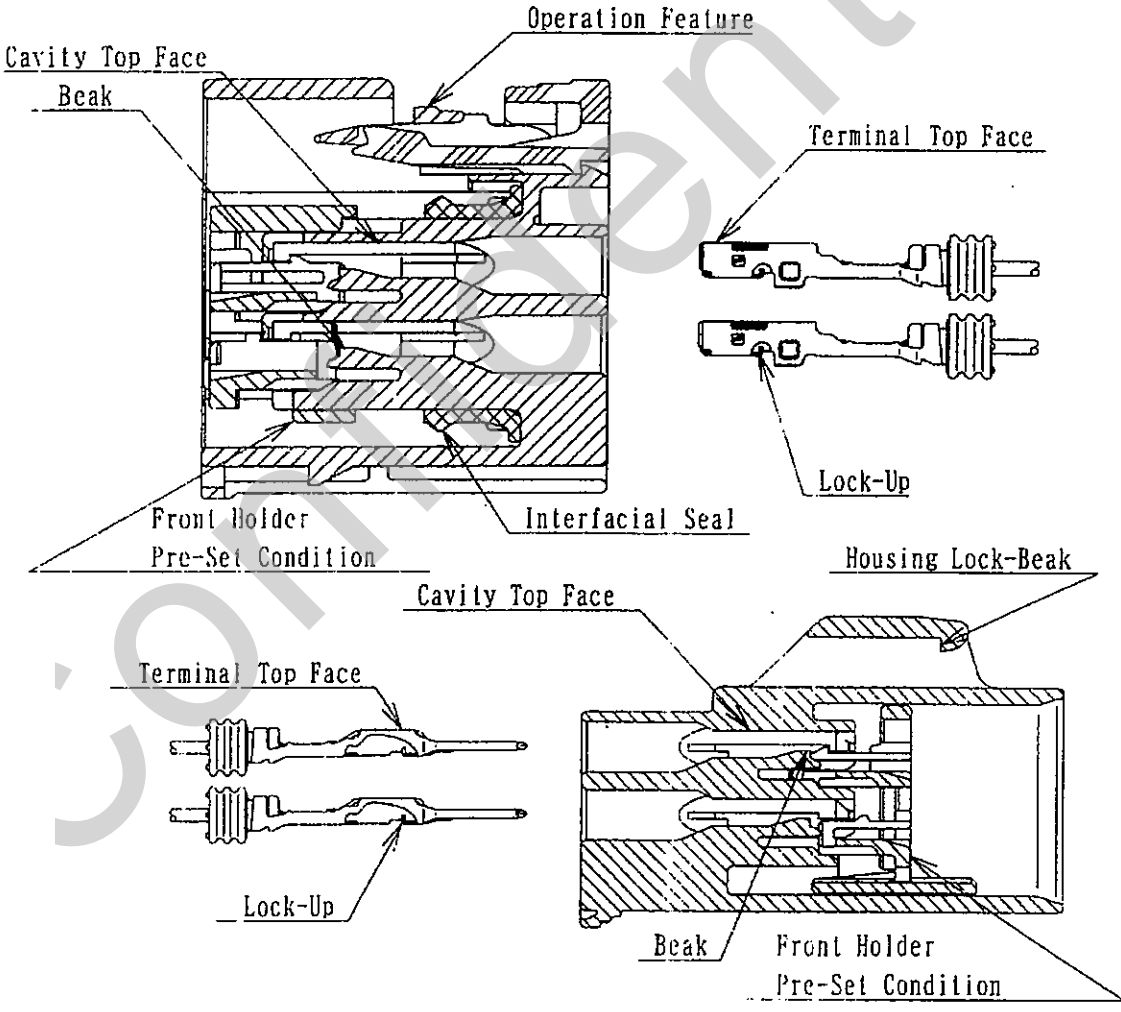

<NOTE> If the front holder is not in the pre-set position, the front holder must first be moved to the pre-set position before terminal insertion.

5-2. Male Front Holder Setting on Male Housing

When moving the front holder from the pre-set position to full-lock position, push at area A with the special tool.

- When pushing area A, pay attention not to harm the sealing surface of the housing or the male tab with the tool.
- If it is damaged; replace it with a new one.
- If the front holder is not pushed in to the full-lock position smoothly, the terminal may not have been inserted correctly. (refer to 5-2. 1)) Do not push in by force.

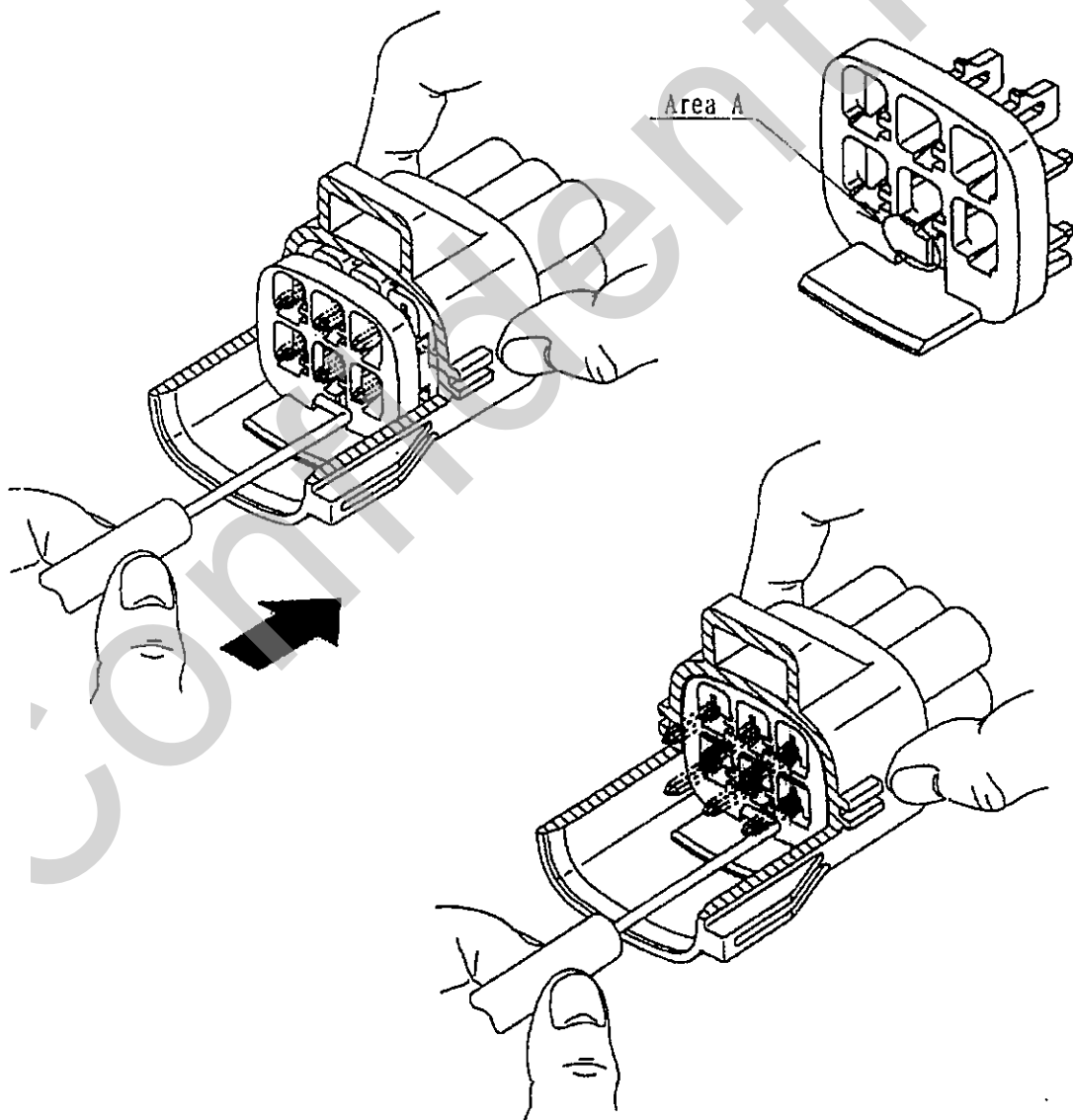

) Male Front Holder Function

- Engagement of the front holder to the full-installed position cannot be completed if one of the following conditions exist :

* Male terminal(s) is not fully inserted into the cavity.

* Male terminal(s) installed in the wrong orientation.

- After condition(s) noted in item two is/are corrected, the holder can be fully installed. Failure to correct these conditions prior to full holder installation could result in damage to either the holder or the housing.

- Confirmation of full holder installation must be taken by checking refer to the page before.

Care should be taken to avoid the possibility of partial front holder installation.

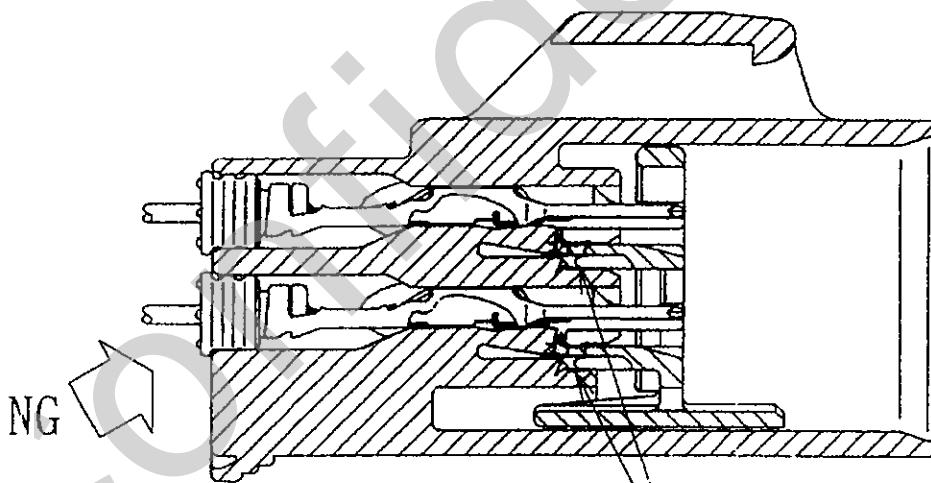

Partial Front Holder Installation

5-3. Female Front Holder Setting on Female Housing

The front holder will either be in the pre-set position or full-lock position on the housing. The diagrams below illustrate the appearance of each condition. The spacer can be moved from the pre-set to full-lock position by deflecting the operation arm as shown.

- The operation arm of the holder should be deflected prior to moving the spacer between positions. Failure to deflect the operation arm could result in damage to either the housing or holder feature.
- If the front holder is not pushed in to the full-lock position smoothly, the terminal may not have been inserted correctly. (refer to 5-3. 1)) Do not push in by force.

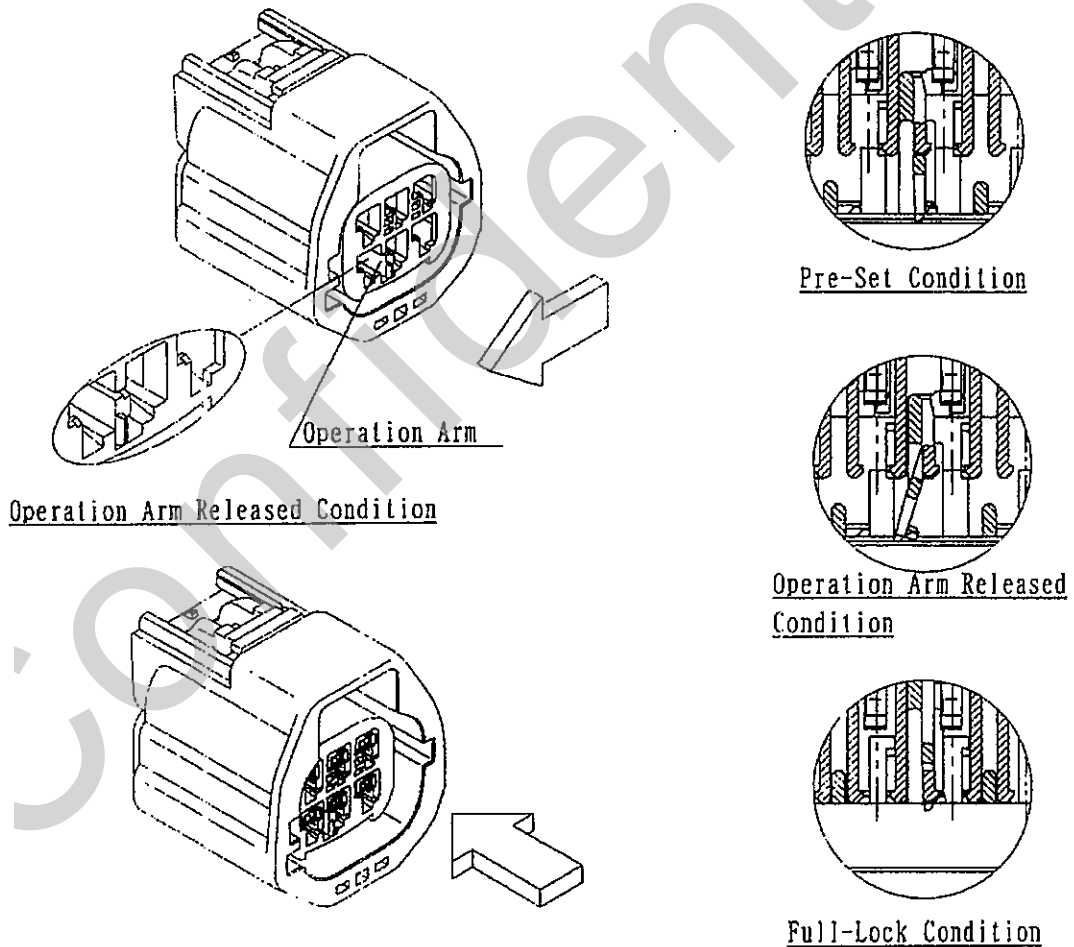

<NOTE>

- Must not pull out the front holder more than necessary because it is feared that the primary locking device might be deformed or broken.
- Pay attention not to deform terminal, etc.

1) Female Front Holder Function

The front holder must be in the pre-set position prior to the installation of terminals. After installation of all applicable terminals, the front holder must be moved to the full-lock position.

• Engagement of the front holder to the full-installed position cannot be completed if one of the following conditions exist :

* Female terminal(s) is not fully inserted into the cavity.

* Female terminal(s) installed in the wrong orientation.

• After condition(s) noted in item two is/are corrected, the holder can be fully installed. Failure to correct these conditions prior to full holder installation could result in damage to either the holder or the housing.

• Confirmation of full holder installation must be taken by checking refer to the page before.

Care should be taken to avoid the possibility of partial front holder installation.

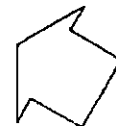
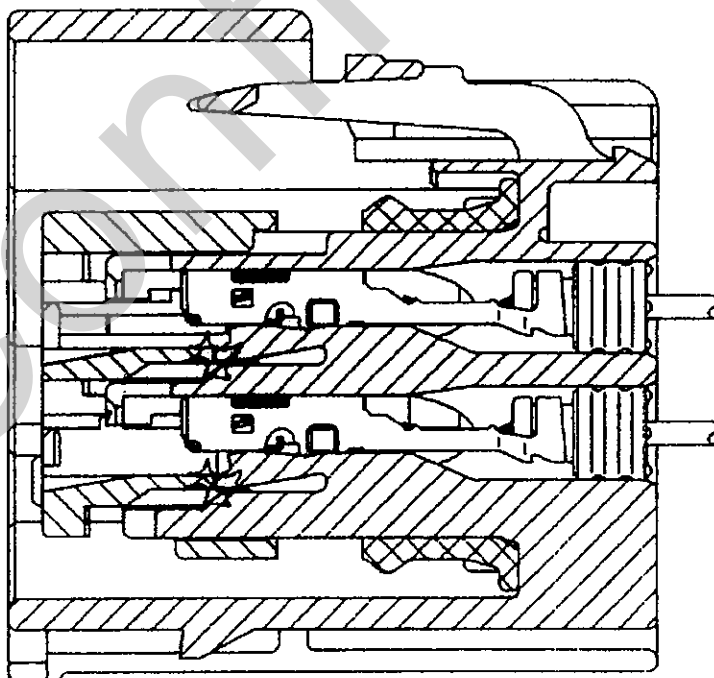

NG

6. Terminal and Front Holder Removal Instructions and Precautions

The following procedures should be used when removing and/or servicing the terminals of this connection system.

6-1. Disengagement of Front Holder from Full-Lock Position, Mail

- As shown below, insert hook tool into slot provided. As slight pull of hook tool in direction of the arrow will release the holder for terminal removal.
- When disengaging the front holder from full-lock position, pay strict attention not to harm the sealing surface or the male tab with special tool.
- If the sealing surface or the male tab is damaged, replace it with a new one.
- Check if the front holder is surely returned to pre-set position.

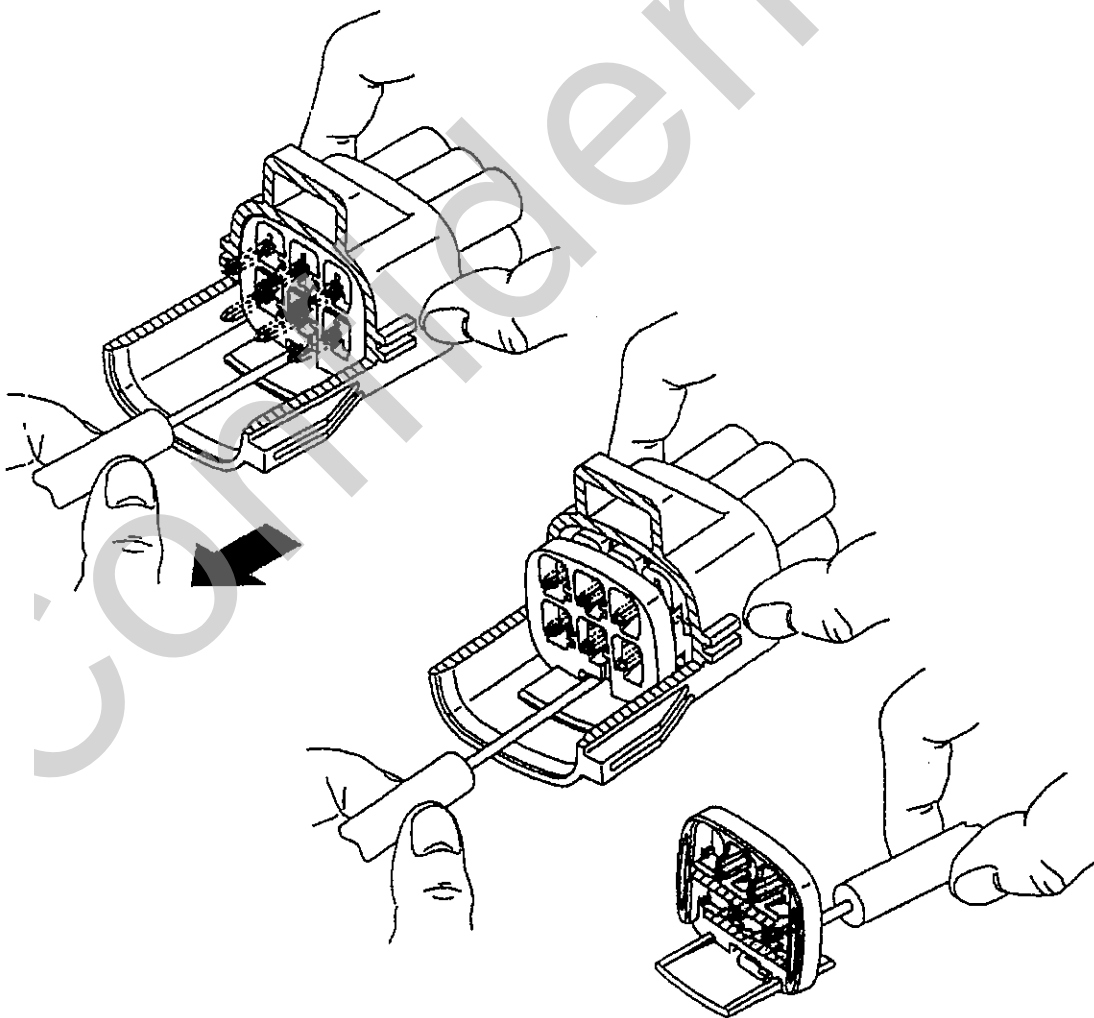

- f-2. Disengagement of Front Holder from the Full-Lock Position, Female.
- As shown below, move the operation arm of the front holder from right to left to release the secondary lock of the front holder.
 - Pull out the front holder to its primary locking position while the operation arm is being deflected.
 - Check if the front holder is surely returned to the primary locking position.

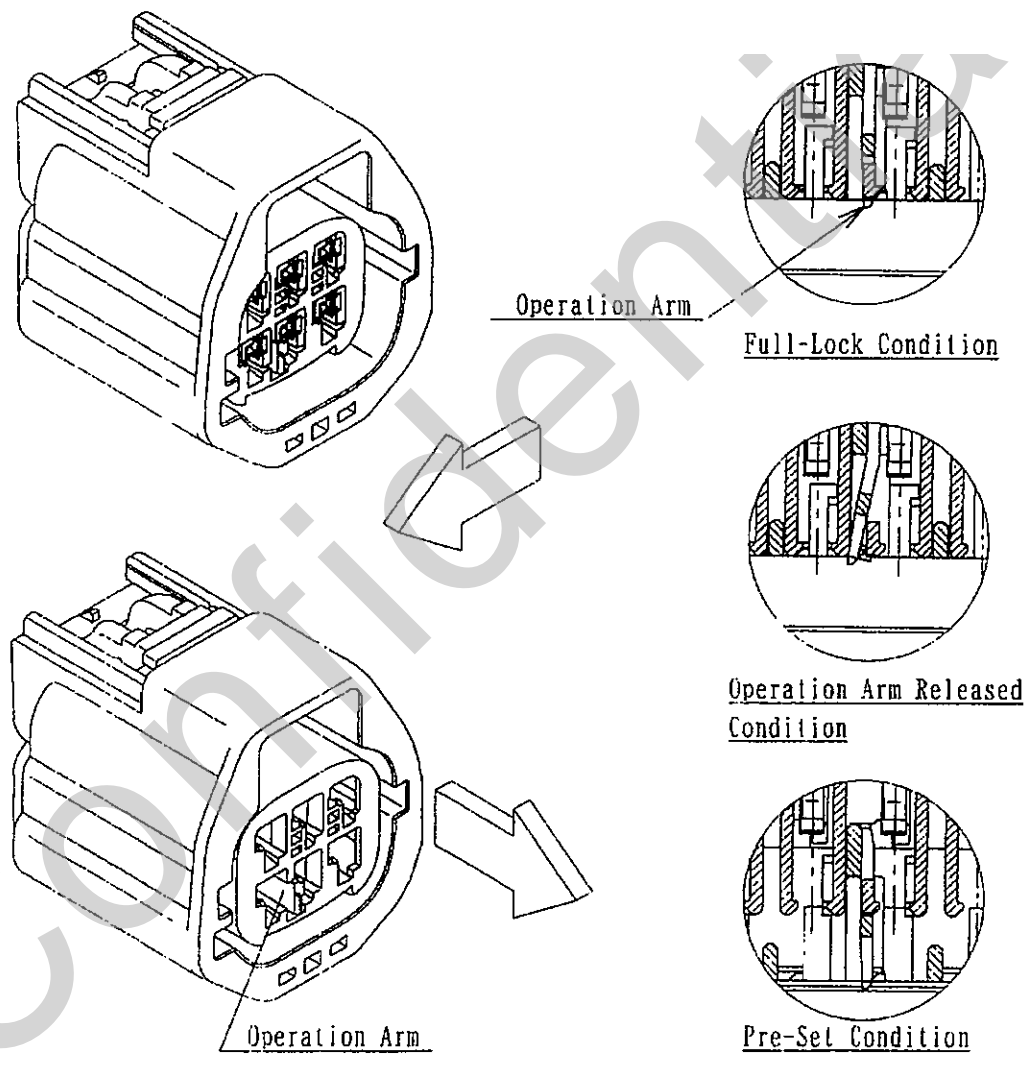

<NOTE>

- Must not pull out the front holder more than necessary because it is feared that the primary locking device might be deformed or broken.
- When removing terminal with jig, pay attention not to deform terminal, etc.

6-3. Terminal Removal

The terminal removal operation should be performed by trained personnel only. Probing of the terminal/cavity by technicians not familiar with the removal process could result in damage to the terminal and/or connector.

- Push the applicable wire lightly to assure the terminal is fully forward in the terminal cavity.
- Insert the removal tool parallel to the cavity into the face of the terminal cavity on the next page. The tip of tool must be positioned between the servicing tab of the flexible arm and the terminal.
- With the flexible arm deflected, pull the wire parallel to the cavity to remove the terminal from the cavity. If the terminal does not disengage easily from the housing, repeat the steps previously outlined.
- If any damage is visible on the terminal and/or housing, the affected component should be replaced; repairs should not be attempted.
- See illustrations on following pages.

• Male Terminal Removal

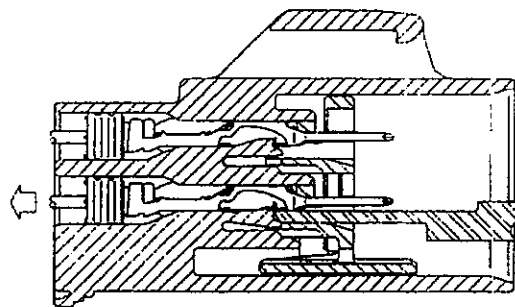
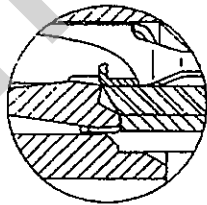
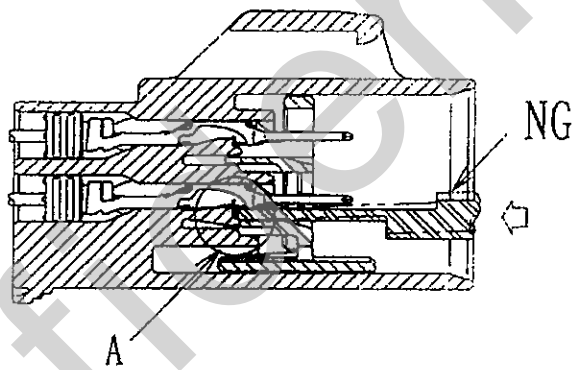
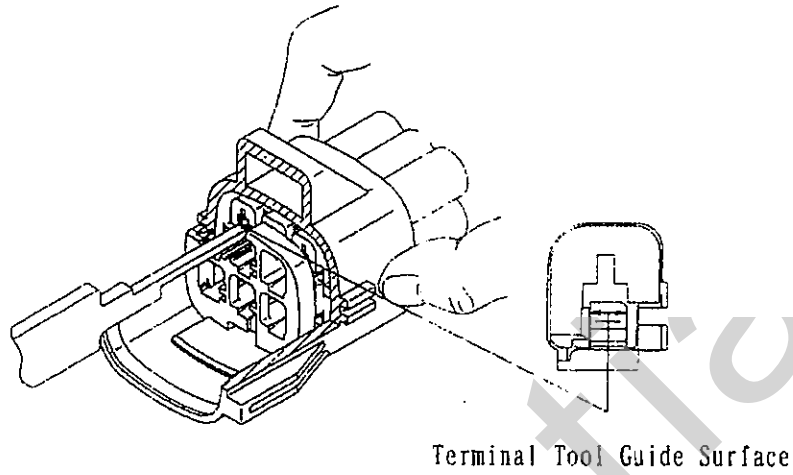

Female Terminal Removal

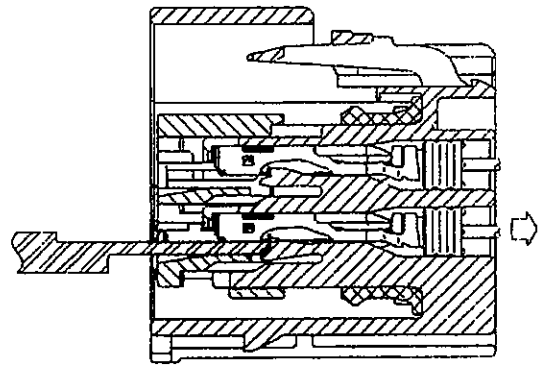
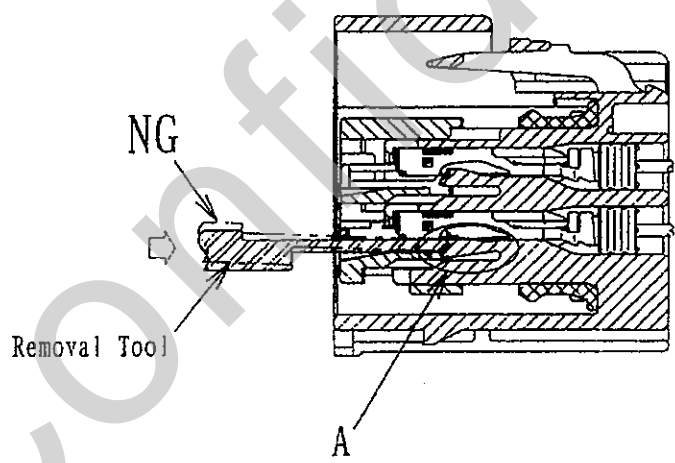
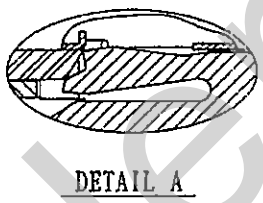
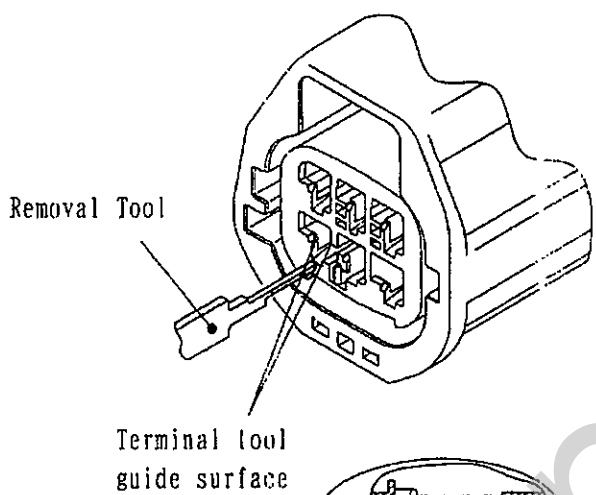

7. Dummy Plug Setting and Removal Instructions and Precautions

7-1. Dummy Plug Setting

The dummy plug is pushed into the open cavity by finger etc.

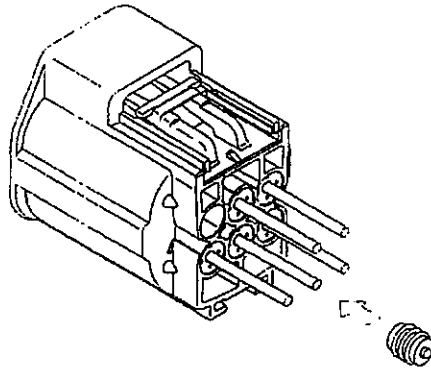

<NOTE> Make sure that the dummy plug has been fully inserted and that the rear side of the seal is not protruding from the cavity.

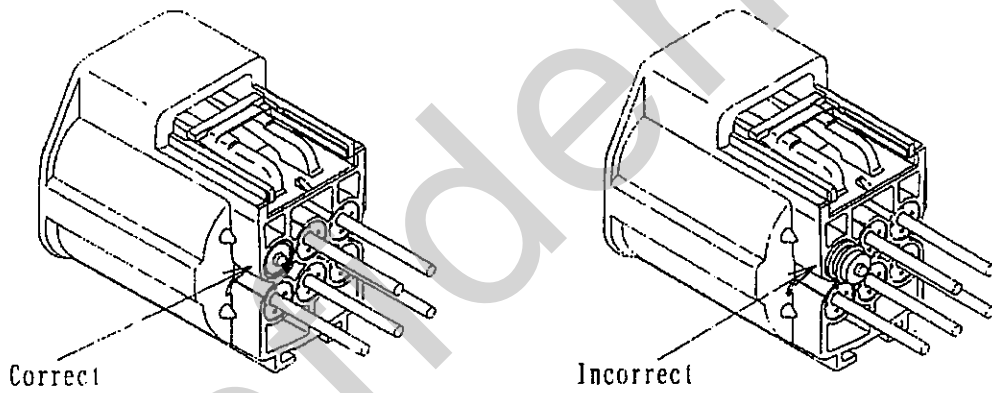

7-2. Dummy Plug Removal

The dummy plug is drawn out from the housing by fingers or pliers etc.

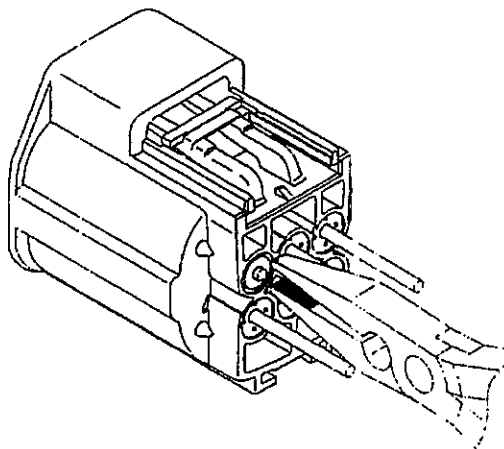

8. Connector Position Assurance (CPA) Function

8-1. How to Lock the CPA

- When the male and female connectors are mated completely, the CPA may be slid into position against the back wall. The back wall is marked by 'A' in the illustration below.

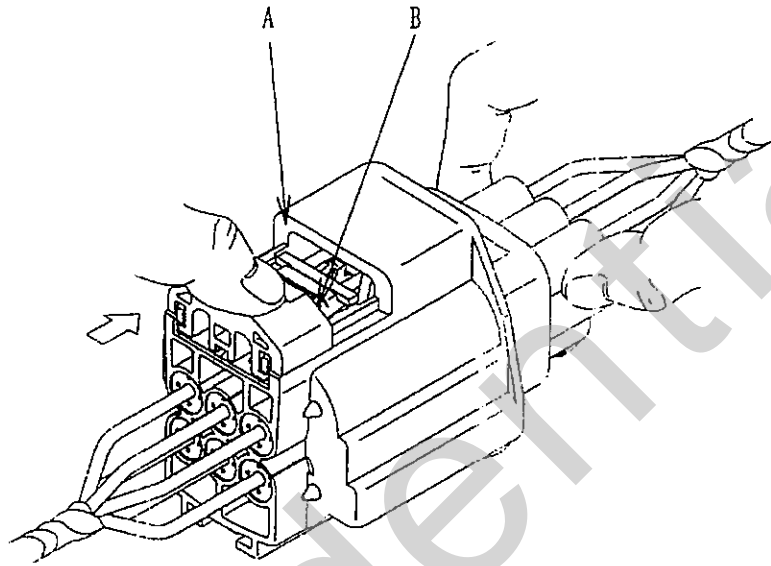

- If the male and female connectors are not fully mated, the CPA, marked by 'B' will not slide to the back connector 'A' (see illustration below). The CPA should never be forced into position, it should slide smoothly and come to rest against the back wall of the connector. If the CPA does not slide smoothly, check and make sure that the connectors are fully mated.

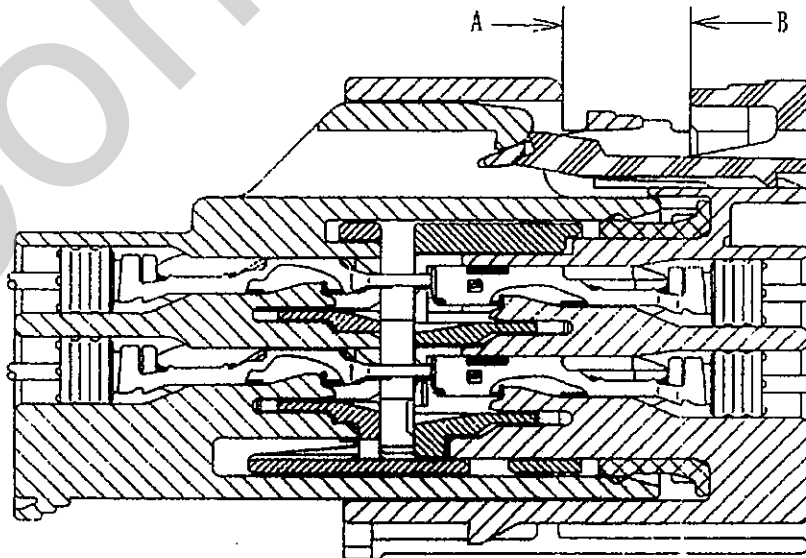

8-2. How to Unlock the CPA

The illustration below shows the CPA in a fully locked position. In order to release the CPA from the locked position, press and slide in direction of the arrow

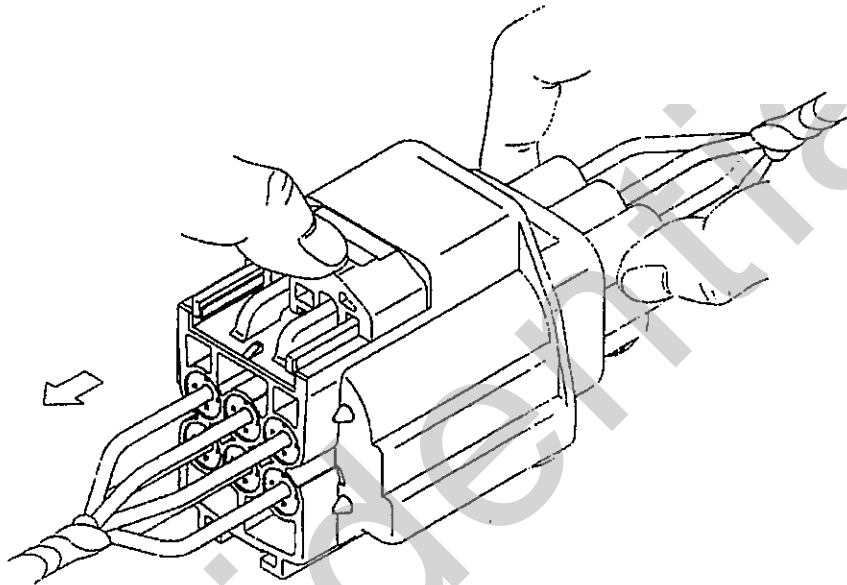

9. Precautions During Wire Harness Assembly

9-1. Wire Harness Assembly

- Avoid tangling the leads which could cause the terminated wires to become hooked and/or damaged.
- Because breakage may occur on wire seal of crimped terminal during transportation, operator should confirm no damage on the wire seal before usage.
- Wires of inadequate length should be discarded rather than forced into the connector. 'Stretching' of the circuit could result in wire breakage or housing/terminal damage.
- When ultrasonic is employed to connect components (terminal, wire, etc...), confirm that ultrasonic cause no negative effect on terminal and connector before the application.

9-2. Taping

Wires which will be taped should be of similar length. Taping of circuits of different length could result in a concentration of force on the shortest wire, resulting in Terminal Pull-Out.

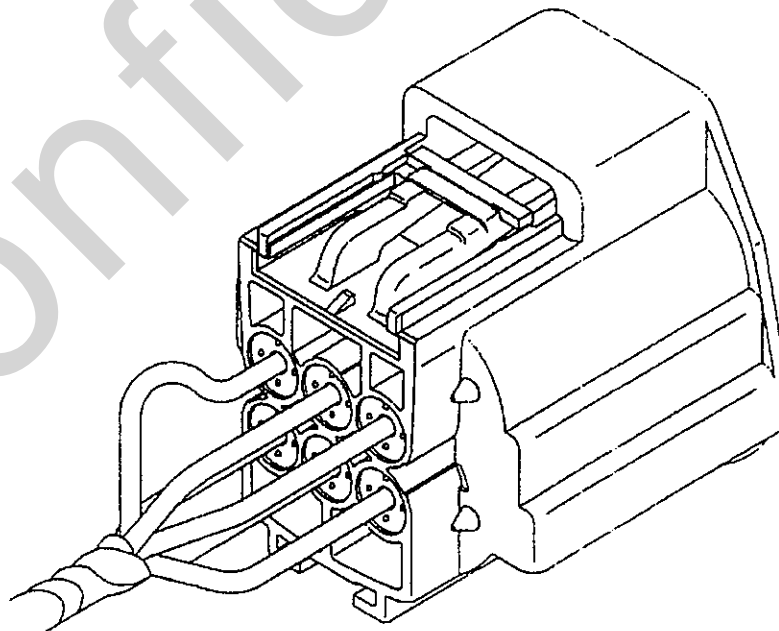

9-3. Precautions During Inspection

- Jigs used for routing and/or continuity inspection should be calibrated for the tolerance equivalent to that of the dimension of mating component. Use of jigs with greater tolerance variation than that of the mating component could result in damage to the housing and/or terminal.
- During routing inspection, in case a jig is used to contact female terminal, it should be calibrated for the tolerance equivalent to that of the dimension of male connector. Use of jigs with greater tolerance variation than that of male connector could result in damage to female terminal.
- A probe pin should be inserted for continuity inspection purpose. The recommended location for the insertion of the probe pin is shown in the illustration below (to prevent terminal spring deformation).

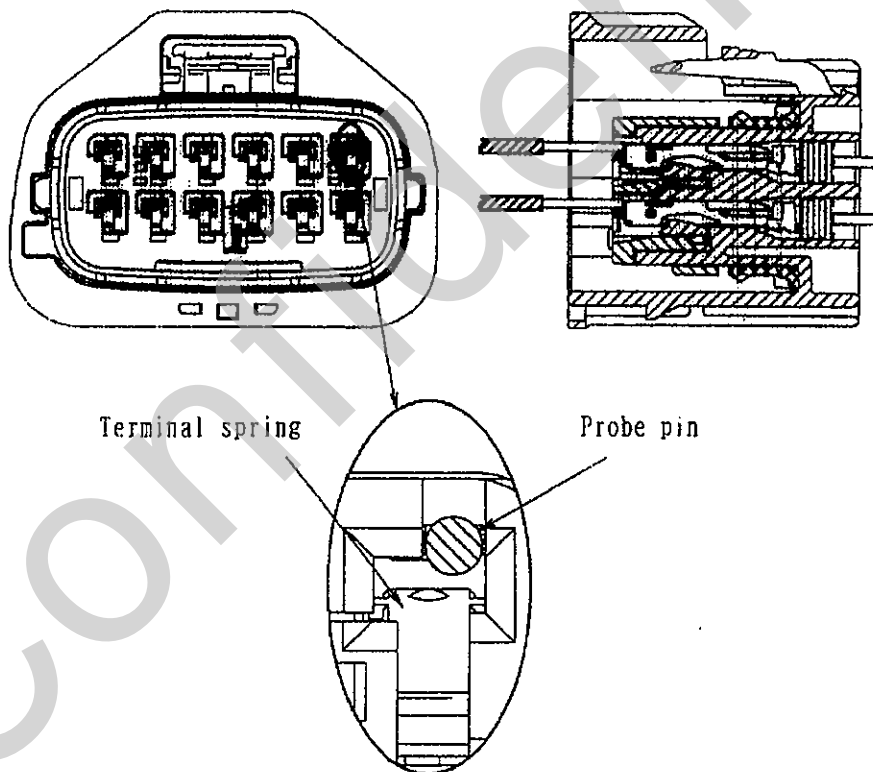

- Damaged and/or deformed housing/terminal should be replaced regardless the degree of damage/deformation.

10. Notice for Packing of Wire Harness

As with many plastic parts the connector may be damaged if external force is applied to the connector during transportation or storage. To prevent damages, please take the following actions as well as the standard packaging and handling procedures:

When packing wire harness in layers, please use paper corrugate/corrugate dividers for each layer including layer dividers, vertical dividers, internal supports, and partitions to equally distribute weights of upper-layer harnesses from being unequally applied to the lower-layer harnesses, as shown below.

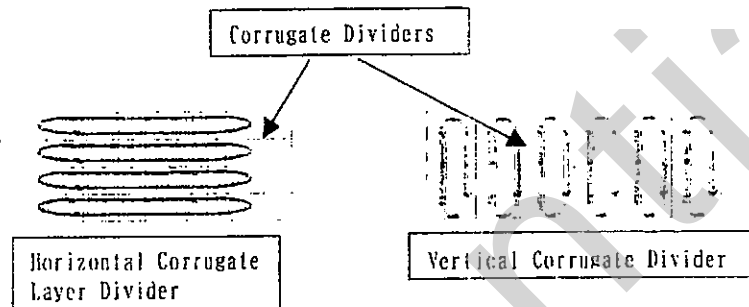

Junction block, relay box, protectors, brackets, and any heavy and/or bulky item must be placed on the bottom of the carton or the divider to prevent weight of such item from being applied to the connector as shown below.

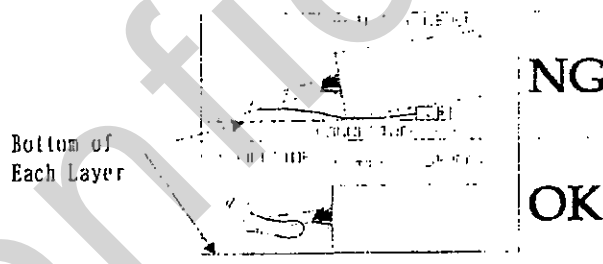

The connector must be positioned outside or in the center of the harness bundle, to prevent the weight of the harness from being applied to the connector.

Sample harness sketch. Place connectors inside and outside of bundled W/H to protect connectors from weight of the W/H.

Wire harness bundle size must fit the carton to prevent shifting of wire harness during transportation or storage. See below illustration.

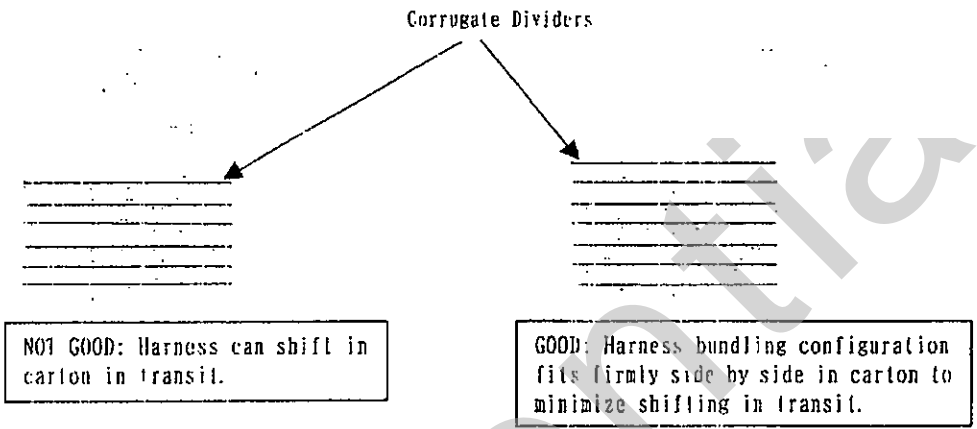

If the connector housing is 'taped back' on the wire harness bundle, assure that the housing lock or other flexible member of the connector is positioned away from the wire harness bundle. See reference illustration below.

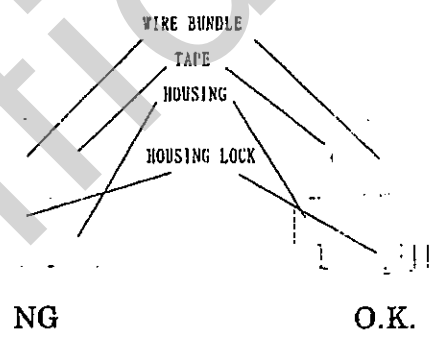

Extra care must be taken to prevent wire harnesses tangling which causes damages to the connector when the wire harness is removed from the carton at the vehicle assembly.

After transportation or storage, the connector must be checked for damages.

YAZAKI SHALL NOT BE LIABLE FOR ANY DAMAGES RESULTING FROM MISUSE OR FAILURE TO FOLLOW THE ABOVE INSTRUCTIONS

11. Precautions During Wire Harness Installation into the Vehicle

11-1. Connector Mating

Upon confirmation that the proper connectors are being mated (i. e. proper keyway is confirmed), the connectors should be smoothly mated. Unnecessary scooping or wrenching of the connectors should be avoided.

- Confirm that the front holder has been surely full-locked.
(In case it has not been full-locked, refer to 5-2 and 5-3.)
- Push the connectors until "click" sound which locking beak is locked is heard.
(During mating, do not press locking key.)
- Confirm that connectors have been surely mated by pulling male/female connectors lightly.

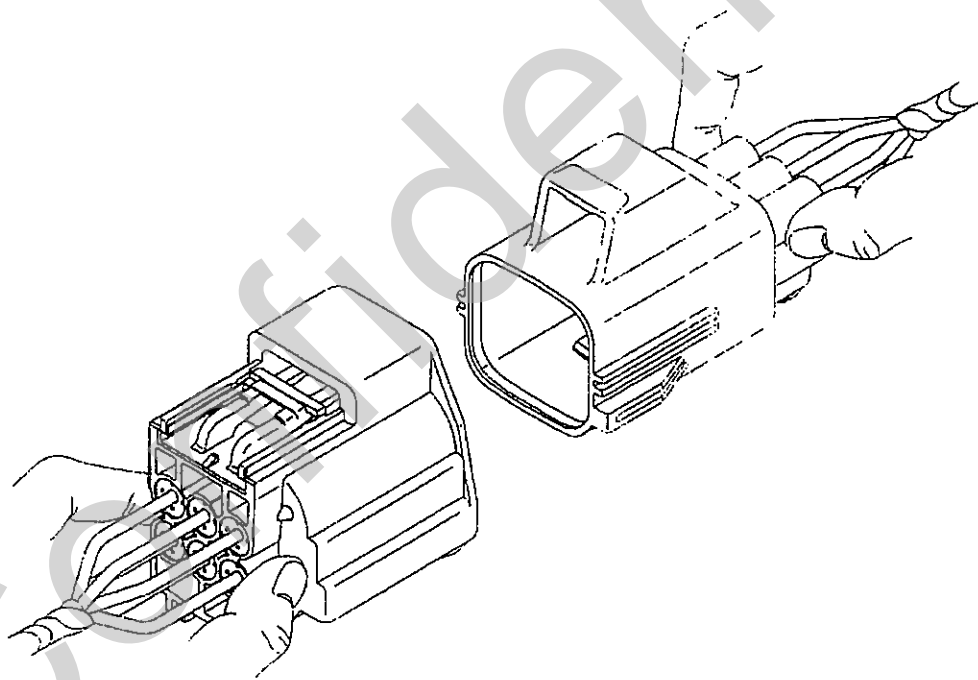

11-2. Connector Servicing

Connector disengagement can be facilitated by pulling the lever out and pulling apart the male and female connectors. During the removal process, the wires of the connector should not be held or pulled. Application of force to the wires could result in damage to the individual components of the connector.

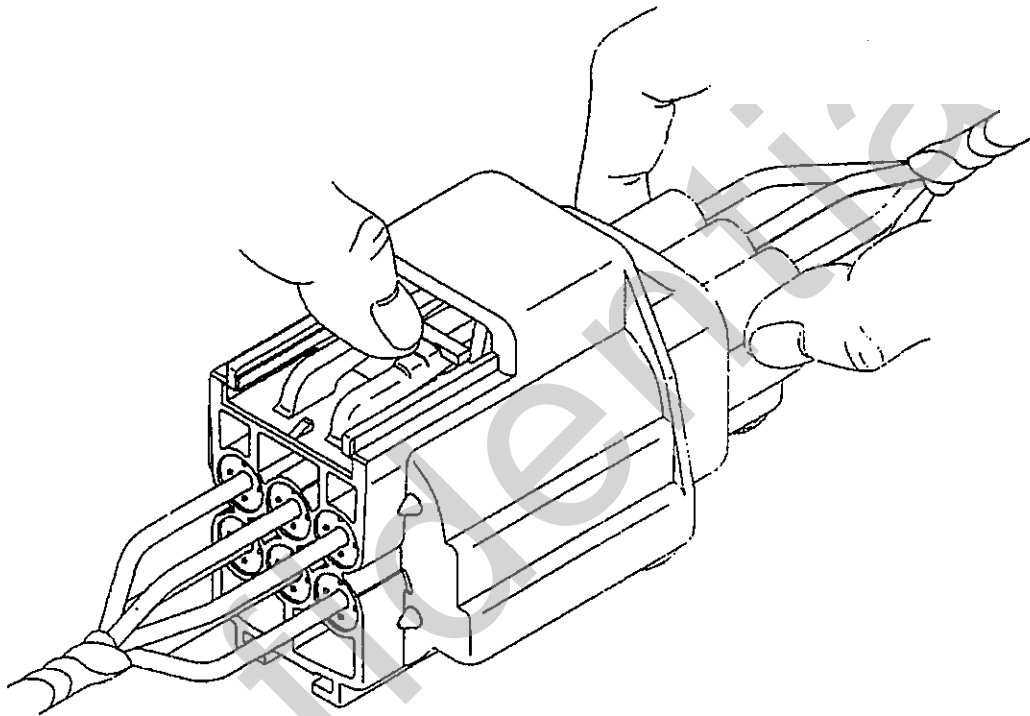

© Connector Configurations and Figures of Part Numbers

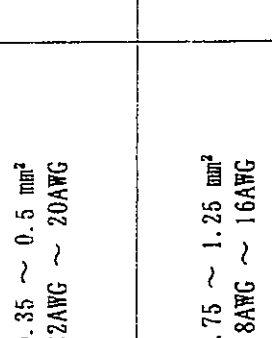
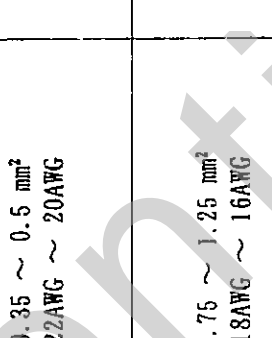
YAZAKI PART NO. (PART NAME)	SHAPE	APPLICABLE WIRE SIZE	REMARK
7114-4102-02 (1.5 SYSTEM CONNECTOR SEALED TERMINAL MALE TIN PLATING)		0.35 ~ 0.5 mm ² 22AWG ~ 20AWG	
7114-4102-08 (GOLD PLATING)		0.75 ~ 1.25 mm ² 18AWG ~ 16AWG	
7116-4102-02 (1.5 SYSTEM CONNECTOR SEALED TERMINAL FEMALE TIN PLATING)		0.35 ~ 0.5 mm ² 22AWG ~ 20AWG	
7116-4102-08 (GOLD PLATING)		0.75 ~ 1.25 mm ² 18AWG ~ 16AWG	
7116-4103-02 (1.5 SYSTEM CONNECTOR SEALED TERMINAL FEMALE TIN PLATING)		1.50 ~ 2.0 mm ² 14AWG	
7116-4105-02 (1.5 SYSTEM CONNECTOR SEALED TERMINAL FEMALE TIN PLATING) ※ 1			

※1 : Reference to next page.

Terminals for 1.5sys with 1.5mm² & over should be used only for those applications where excessive voltage drop in a small size wire may adversely affect the function of the circuit.

Maximum applied current on the wire of 1.5mm² & over for 1.5sys should not exceed 15A. Maximum applied current recommendation based on Bench-Test results only.

(Test conditions: Single Circuit, 20°C Ambient, Open Air, 1.25mm^{2 2)} wire, 20°C ROA.)

Appropriate de-rating should be considered based on specific application requirements (Ambient Temperature, Pole Quantity, Wire Size, etc.)

Description	Max Wire Size	Wire Sizes for Applications with Excessive Voltage Drop	Max Current Recommendation ¹⁾
1.5sys	1.25mm ²	1.5mm ² or 2.0mm ^{2 3)}	15A

1) Single Circuit, 20°C Ambient, Open Air and 20°C ROA with Max Wire

2) 1.25mm² = 16AWG

3) 2.0mm² = 14AWG

<Appendix> Applicable Wire Size for Sealed YESC

Wire Size	AWG	-	22	-	20	-	18	-	16	-	14
	ISO(mm ²)	0.35	-	0.5	-	0.75	-	1.0	-	1.5	-
1.5sys	Male	O	O	O	O	O	O	O	O	O	X
	Female	O	O	O	O	O	O	O	O	O	Δ

O : Acceptable
 X : Not Acceptable
 Δ : Terminals for Voltage Drop Issue

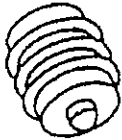
YAZAKI PART NO. (PART NAME)	SHAPE	WIRE OVERALL DIAMETER	REMARK
7158-3030-50 (1.5 SYSTEM SEALED CONNECTOR RUBBER STOPPER)		φ 1.20 ~ φ 1.70	COLOR : RED
7158-3031-90 (1.5 SYSTEM SEALED CONNECTOR RUBBER STOPPER)		φ 1.53 ~ φ 2.20	COLOR : BLUE
7158-3032-60 (1.5 SYSTEM SEALED CONNECTOR DUMMY PLUG)			COLOR : GREEN

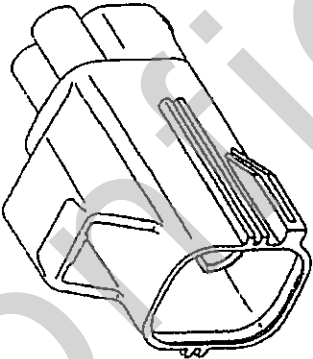
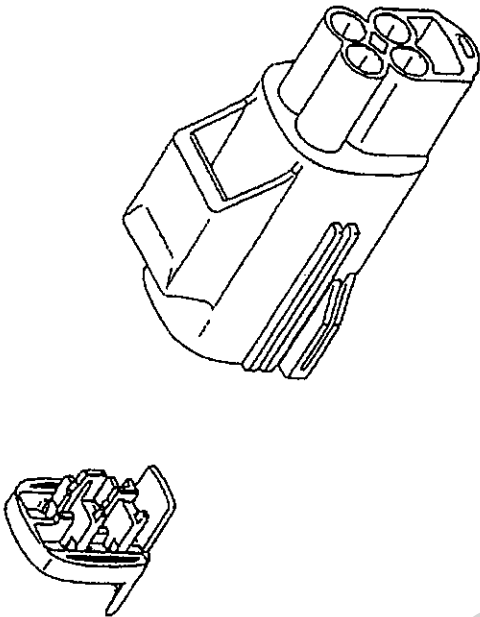
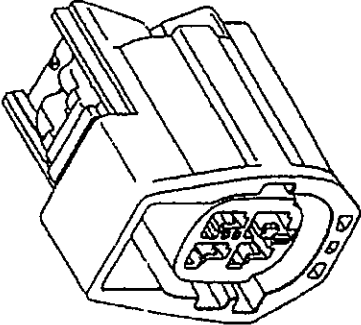
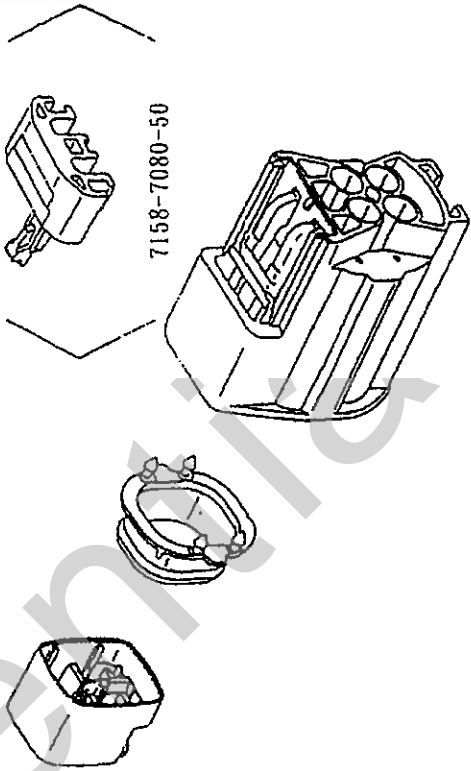
YAZAKI PART NO. (PART NAME)	SHAPE	CONSTRUCTION (PART NO. AND SHAPE)
<p>7282-5543-10 (1.5 SYSTEM SEALED CONNECTOR 4P MALE) (TYPE-A)</p>		
<p>7283-5543-10 (1.5 SYSTEM SEALED CONNECTOR 4P FEMALE) (TYPE-A)</p> <p>7283-5544-10 (with CPA)</p>		 <p>7158-7080-50</p>

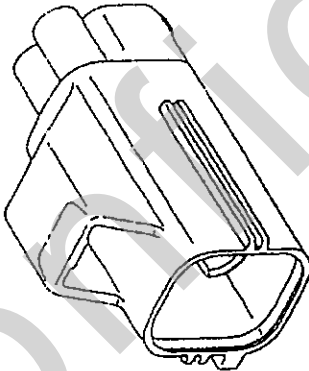
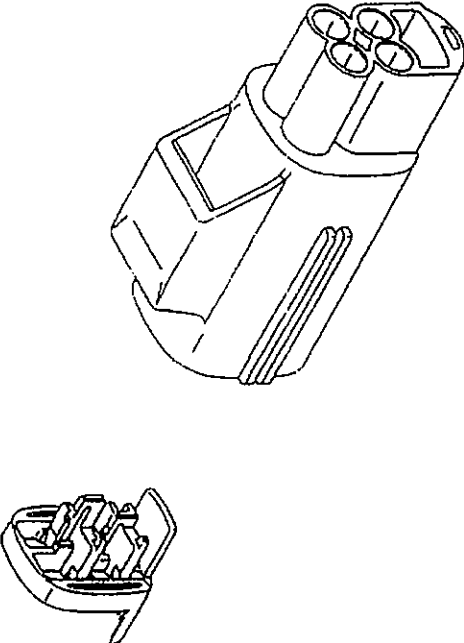
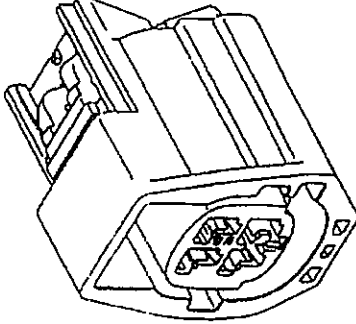
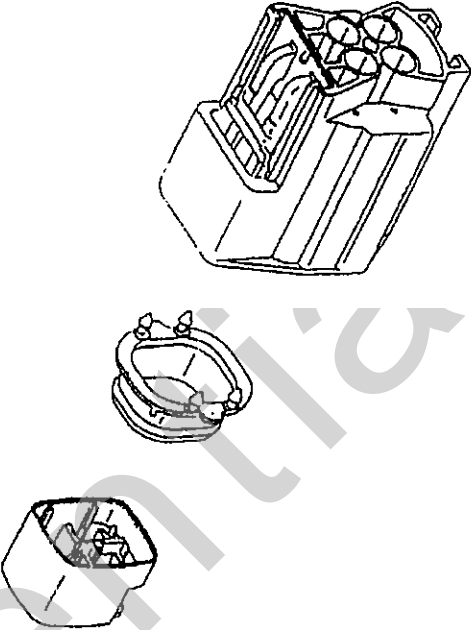
YAZAKI PART NO. (PART NAME)	SHAPE	CONSTRUCTION (PART NO. AND SHAPE)
<p>7282-5889-30 (1.5 SYSTEM SEALED CONNECTOR 4P MALE) (TYPE-B)</p>		
<p>7283-5889-30 (1.5 SYSTEM SEALED CONNECTOR 4P FEMALE) (TYPE-B)</p>		

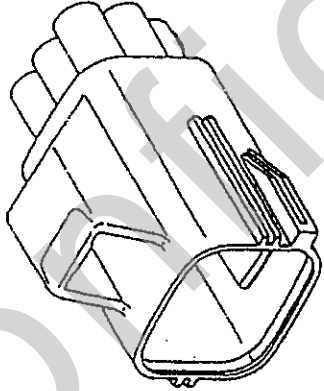
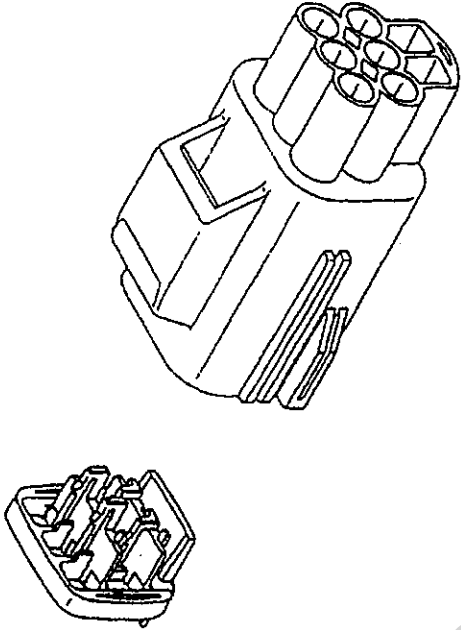
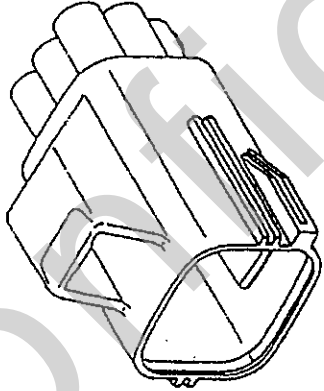
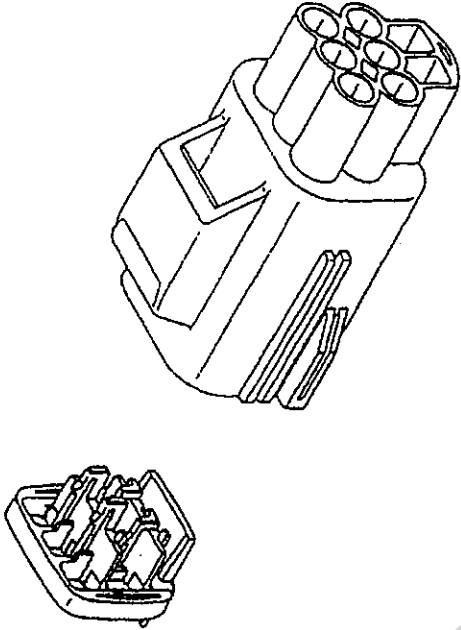
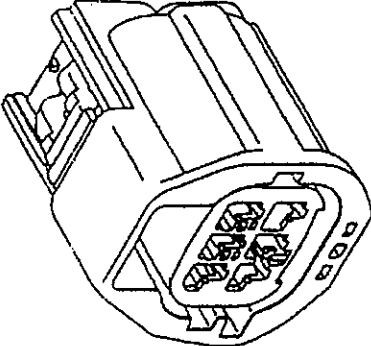
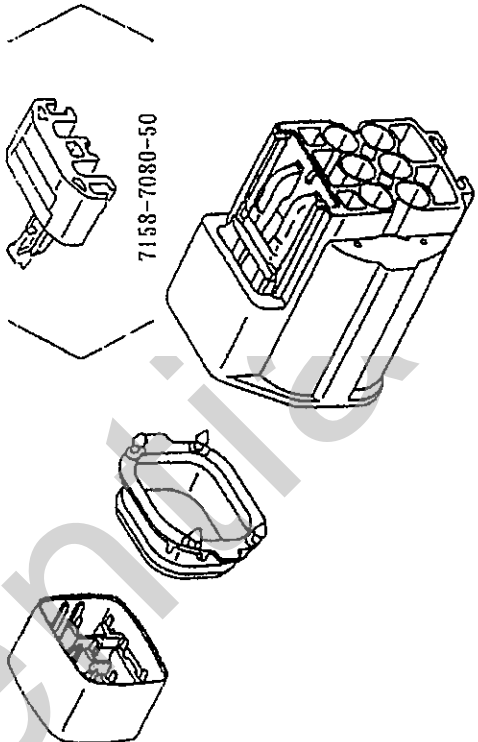
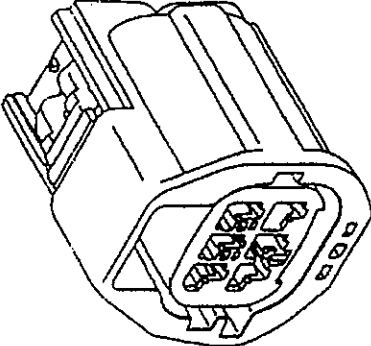
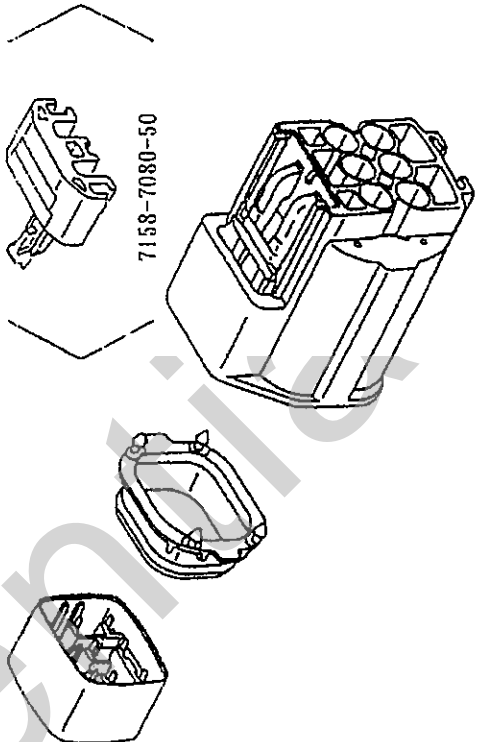
YAZAKI PART NO (PART NAME)	SHAPE	CONSTRUCTION (PART NO. AND SHAPE)
<p>7282-5553-10 (1.5 SYSTEM SEALED CONNECTOR 6P MALE)</p>		
<p>7282-5553-30 (1.5 SYSTEM SEALED CONNECTOR 6P MALE)</p>		
<p>7283-5553-10 7283-5553-30 (1.5 SYSTEM SEALED CONNECTOR 6P FEMALE)</p>		
<p>7283-5554-10 7283-5554-30 (1.5 SYSTEM SEALED CONNECTOR 6P FEMALE) (with CPA)</p>		

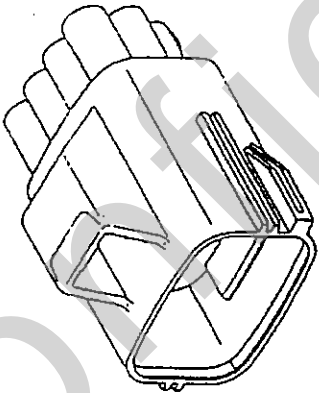
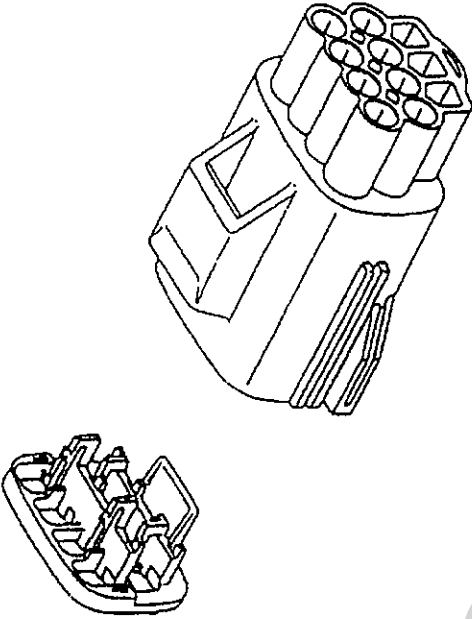
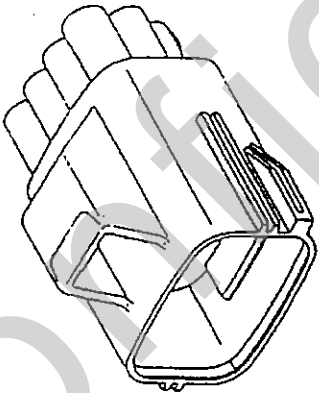
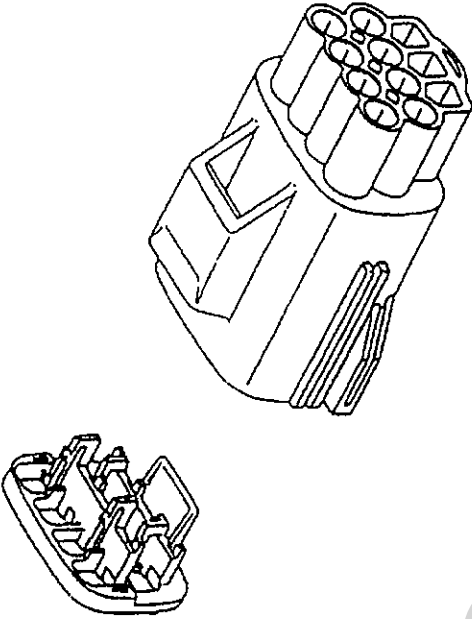
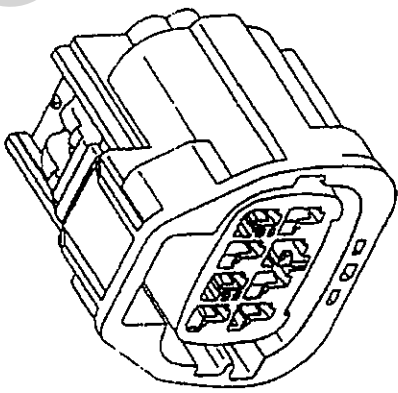
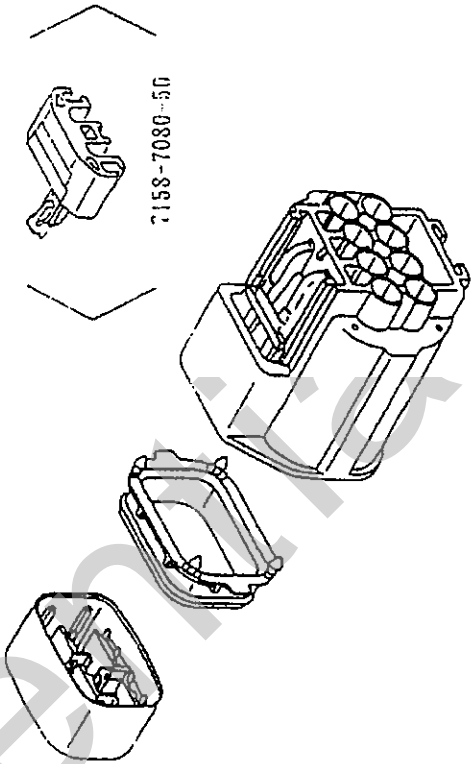
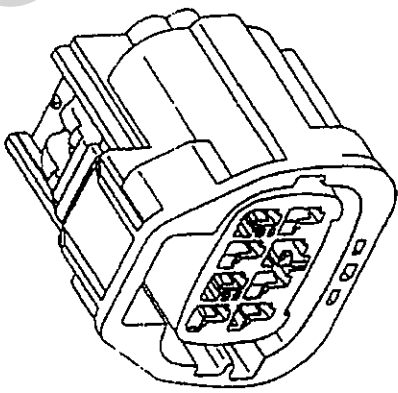
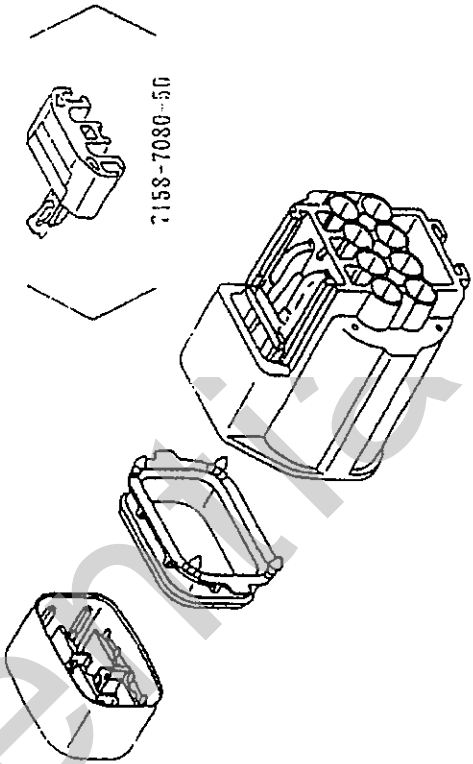
YAZAKI PART NO. (PART NAME)	SHAPE	CONSTRUCTION (PART NO. AND SHAPE)
7282-5684-10 (1.5 SYSTEM SEALED CONNECTOR 8P MALE)		
7282-5684-30 (1.5 SYSTEM SEALED CONNECTOR 8P MALE)		
7283-5684-10 7283-5684-30 (1.5 SYSTEM SEALED CONNECTOR 8P FEMALE)		
7283-5685-10 7283-5685-30 (1.5 SYSTEM SEALED CONNECTOR 8P FEMALE) (with CPA)		

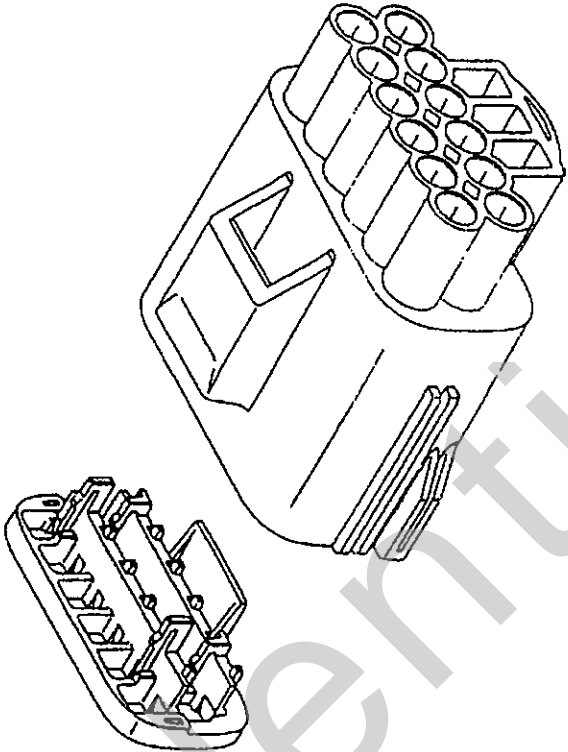
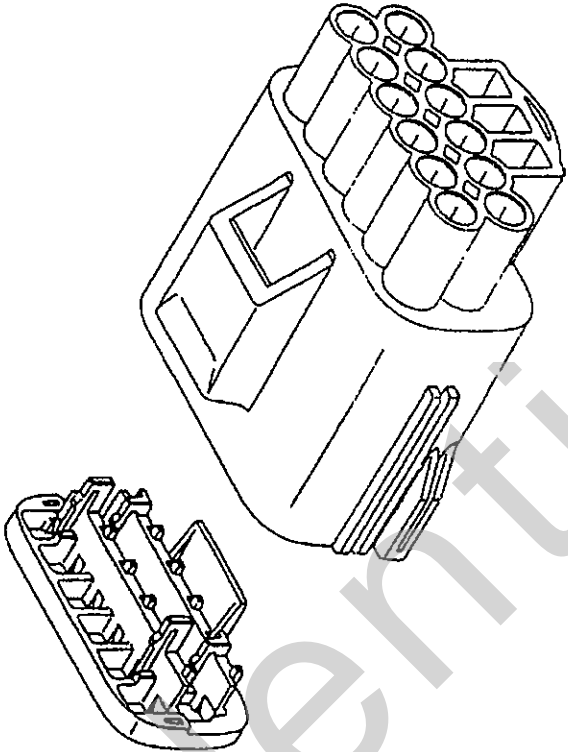
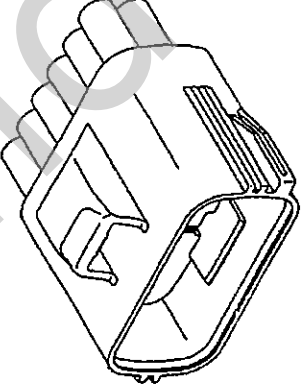
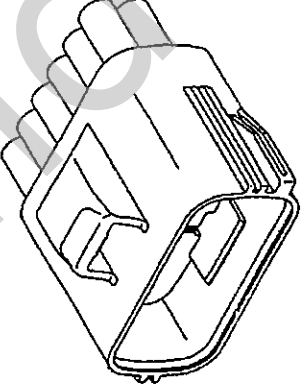
YAZAKI PART NO. (PART NAME)	SHAPE	CONSTRUCTION (PART NO. AND SHAPE)
<p>7282-5545-10 (1.5 SYSTEM SEALED CONNECTOR 12P MALE)</p>		
<p>7282-5545-30 (1.5 SYSTEM SEALED CONNECTOR 12P MALE)</p>		

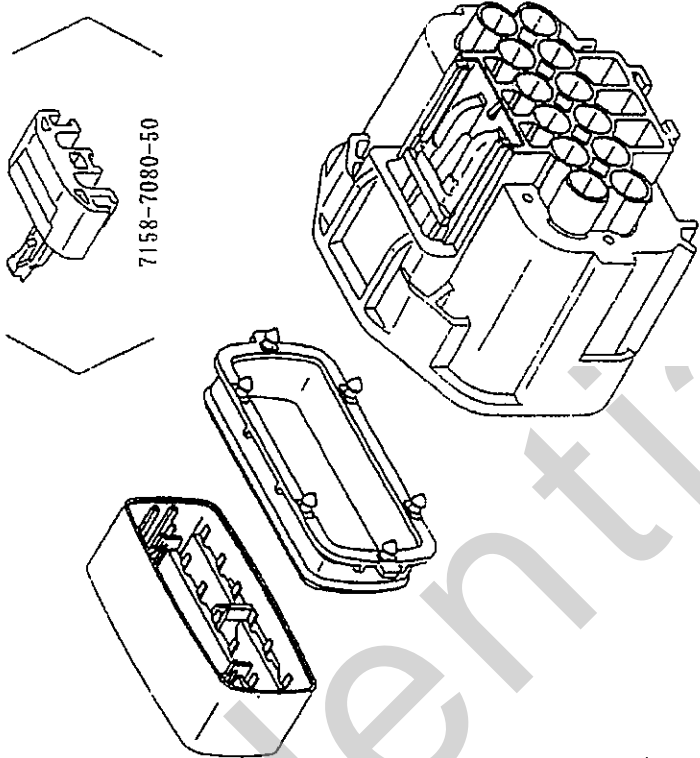
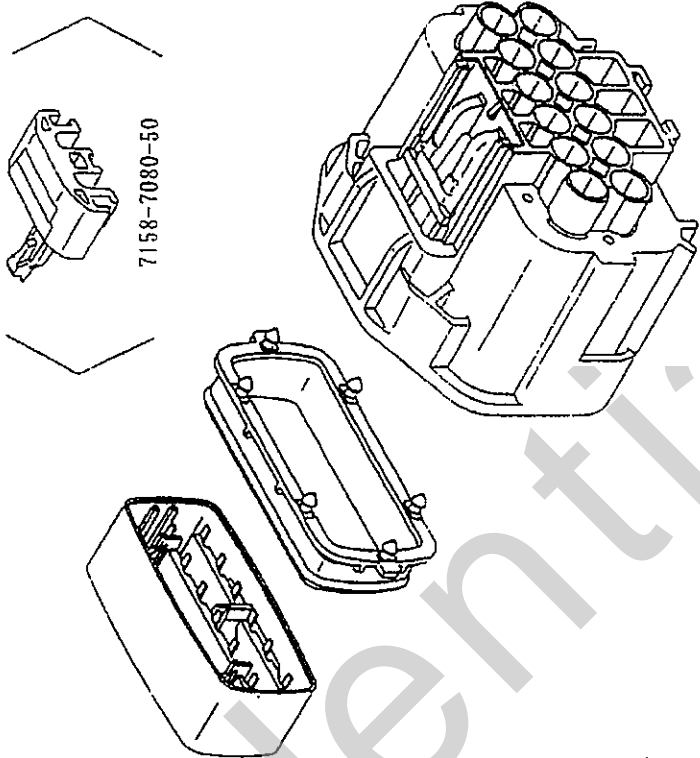
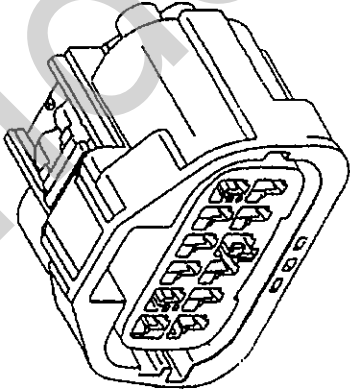
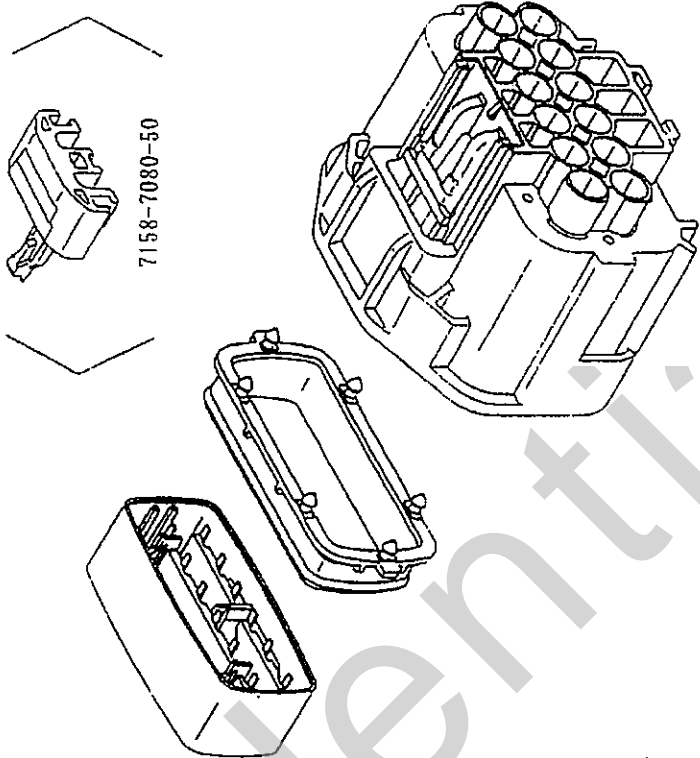
<p>YAZAKI PART NO. (PART NAME)</p>	<p>SHAPE</p>	<p>CONSTRUCTION (PART NO. AND SHAPE)</p>
<p>7283-5545-10 7283-5545-30 (1.5 SYSTEM SEALED CONNECTOR 12P MALE)</p>		
<p>7283-5546-10 7283-5546-30 (1.5 SYSTEM SEALED CONNECTOR 12P FEMALE (with CPA)</p>		

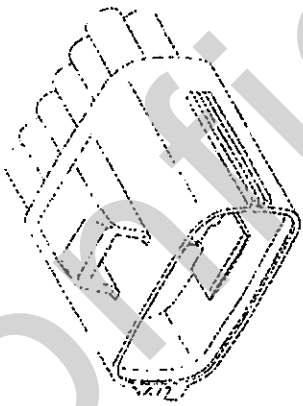
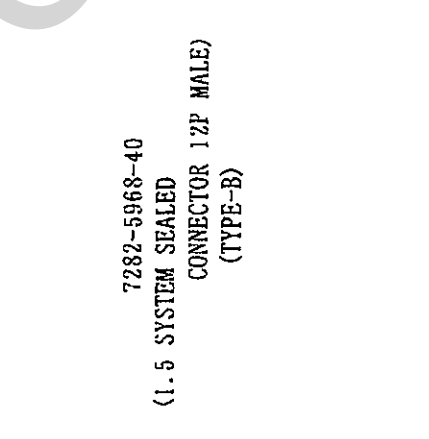
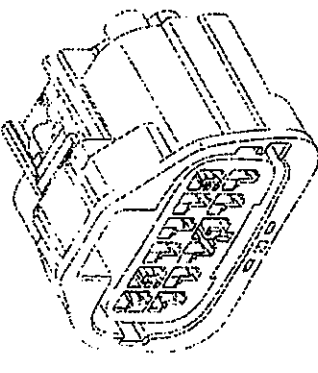
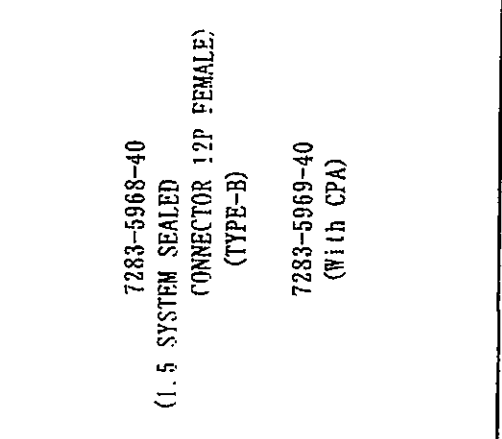
YAZAKI PART NO. (PART NAME)	SHAPE	CONSTRUCTION (PART NO. AND SHAPE)
<p>7282-5968-40 (1.5 SYSTEM SEALED CONNECTOR 12P MALE) (TYPE-B)</p>		
<p>7283-5968-40 (1.5 SYSTEM SEALED CONNECTOR 12P FEMALE) (TYPE-B)</p> <p>7283-5969-40 (With CPA)</p>		

List of Other Connectors Part Number(Isometric drawing in progress)

YAZAKI PART NO.	YAZAKI PART NAME	REMARK
7283-5548-30	1.5 SYSTEM SEALED CONN. 2P(F) TYPE-A	
7283-5549-30	1.5 SYSTEM SEALED CONN. 2P(F) TYPE-A WITH CPA	
7282-5548-30	1.5 SYSTEM SEALED CONN. 2P(M) TYPE-A	
7283-5558-10	1.5 SYSTEM SEALED CONN. 2P(F) TYPE-B	
7283-5559-10	1.5 SYSTEM SEALED CONN. 2P(F) TYPE-B WITH CPA	
7282-5558-10	1.5 SYSTEM SEALED CONN. 2P(M) TYPE-B	
7283-5689-30	1.5 SYSTEM SEALED CONN. 2P(F)	
7283-5541-30	1.5 SYSTEM SEALED CONN. 3P(F) TYPE-A	
7283-5542-30	1.5 SYSTEM SEALED CONN. 3P(F) TYPE-A WITH CPA	
7282-5541-30	1.5 SYSTEM SEALED CONN. 3P(M) TYPE-A	
7283-5691-10	1.5 SYSTEM SEALED CONN. 3P(F) TYPE-B	
7283-5880-10	1.5 SYSTEM SEALED CONN. 3P(F) TYPE-B WITH CPA	
7283-5882-80	1.5 SYSTEM SEALED CONN. 3P(F) TYPE-C	
7283-5883-80	1.5 SYSTEM SEALED CONN. 3P(F) TYPE-C WITH CPA	
7283-5885-30	1.5 SYSTEM SEALED CONN. 4P(F)	
7283-5886-30	1.5 SYSTEM SEALED CONN. 4P(F) WITH CPA	
7283-5547-30	1.5 SYSTEM SEALED CONN. 5P(F)	
7283-5550-30	1.5 SYSTEM SEALED CONN. 5P(F) WITH CPA	
7283-5946-30	1.5 SYSTEM SEALED CONN. 10P(F) TYPE-A	
7283-5947-30	1.5 SYSTEM SEALED CONN. 10P(F) TYPE-A WITH CPA	
7282-5946-30	1.5 SYSTEM SEALED CONN. 10P(M) TYPE-A	
7283-5696-30	1.5 SYSTEM SEALED CONN. 10P(F)	
7283-5697-30	1.5 SYSTEM SEALED CONN. 10P(F) WITH CPA	
7283-5698-10	1.5 SYSTEM SEALED CONN. 10P(F) WITH CPA	
7283-5694-10	1.5 SYSTEM SEALED CONN. 10P(F) WITH CPA	
7283-5694-40	1.5 SYSTEM SEALED CONN. 10P(F) WITH CPA	
7283-5948-10	1.5 SYSTEM SEALED CONN. 10P(F)	
7283-5695-10	1.5 SYSTEM SEALED CONN. 10P(F) WITH CPA	
7283-5695-30	1.5 SYSTEM SEALED CONN. 10P(F) WITH CPA	