

090 コネクタ 取扱説明書①

Handling Manual for 090 Connector①

注)

本取扱説明書は、発行先に対し連絡無しに改訂する場合がありますので、ご了承下さい。

矢崎総業株式会社

矢崎部品株式会社

改訂年月日 2018年05月18日

この度は、弊社コネクタを採用頂き有難うございます。
本説明書は、本製品をご使用頂く上で最低限必要な項目を記載したものです。
取扱の際には、本記載内容を遵守下さい。
弊社は本内容を遵守しないで起こった損害または誤使用により起こった
損害に対しては責任を負いません。

目 次

1. 090 コネクタについて	P. 2
2. 構成部品と各部名称	P. 2
2-1 構成部品	
2-2 各部名称	
3. ターミナル及びハウジングの検査	P. 4
4. 圧着作業について	P. 4
4-1 保管及び運搬	
4-2 圧着作業	
4-3 ターミナル圧着後の製品取扱い	
5. ハーネス製造作業	P. 8
5-1 ハウジングへのターミナル挿入	
5-2 ターミナルの引抜き	
6. ハーネス製品の管理について	P. 11
6-1 検査	
6-2 出荷、運搬、保管	
7. コネクタの嵌合及び取りはずし	P. 11
7-1 コネクタの嵌合	
7-2 コネクタの取りはずし	
7-3 コネクタの嵌合後の回路チェック	
8. 端子及びハウジング一覧表	別紙1～7

1. 090コネクタについて

090コネクタは従来品と比較し、性能・信頼性・作業性を低下させる事なく、小型軽量化を図る事を目的として開発されたコネクタである。

2. 構成部品と各部名称

2-1 構成部品

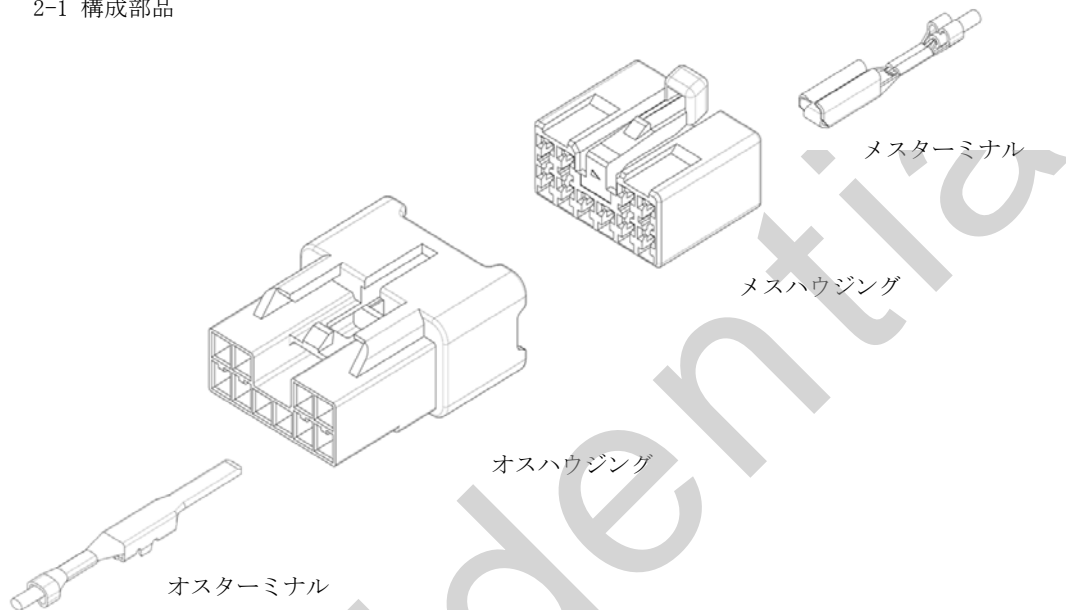

2-2 各部名称

2-2-1 オスターミナル

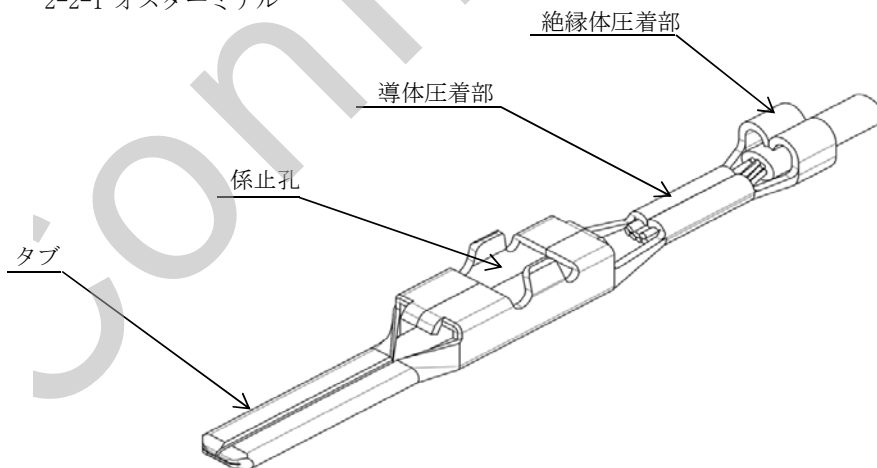

2-2-2 メスターミナル

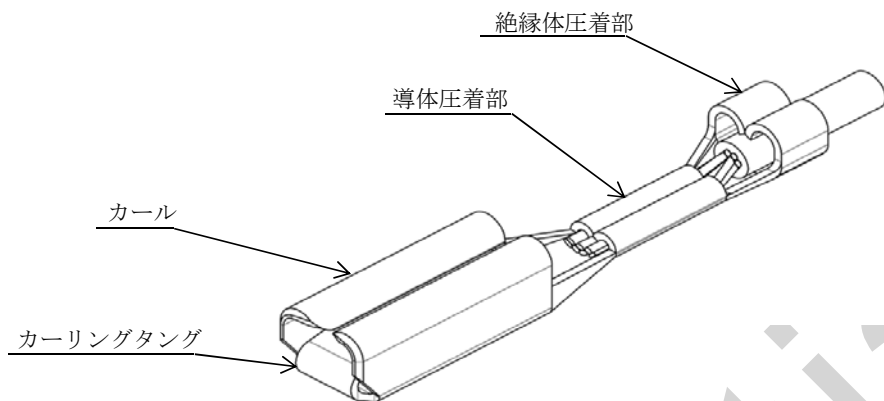

2-2-3 オスハウジング

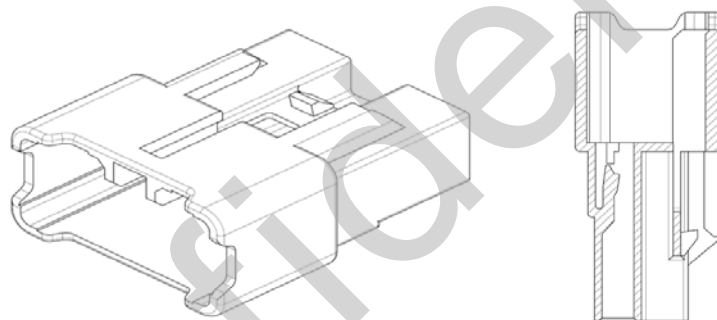

2-2-4 メスハウジング

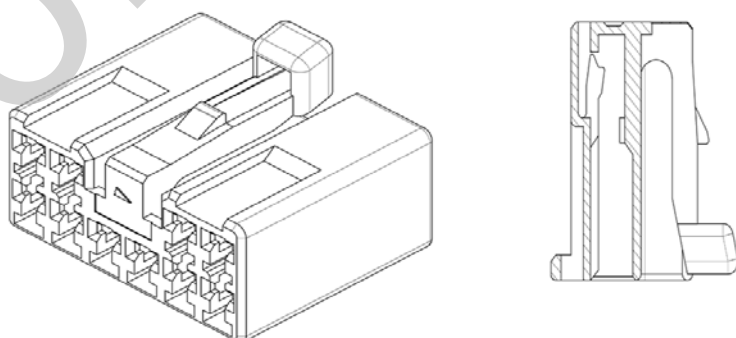

3. ターミナル及びハウジングの検査

当社検査基準に基づき、完全な検査を行なった出荷しておりますが、該当する製品の顧客用図面の内容について検査される事を望みます。

4. 圧着作業について

4-1 保管及び運搬

- ①保管は梱包箱に入れた状態にて、清浄な屋内で且つ常温常湿（5～35℃、45～85%RH）の環境下に保管願います。
- ②梱包箱より取り出して運搬する場合には、必ずリールセンターの金属部を持ちリールを縦にして運搬願います。
- ③使用を中断するリールは、リールがほどけない様に針金等にて先端をフランジに結んでおいて下さい。

4-2 圧着作業

4-2-1 適用電線

- ①自動車用低圧電線 JIS-C-3406
- ②AVS0.2H, AVS-0.3, AVS0.5, AVS0.85, AVS1.25 及び相当品の一本圧着のみに適用します。

4-2-2 注意事項

①斜め切れ

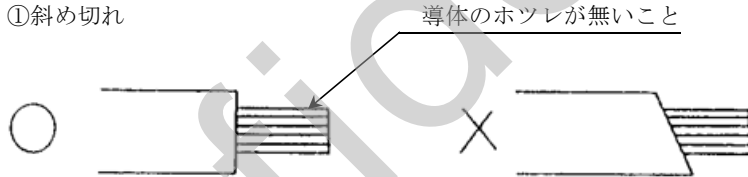

②導体切れ

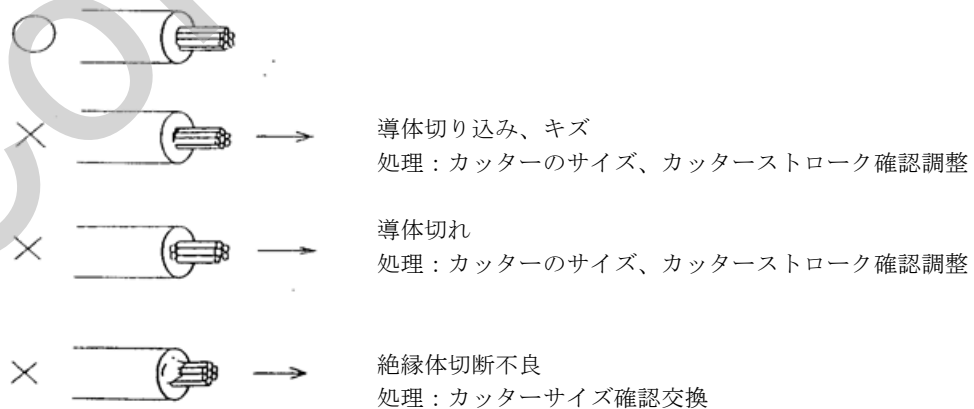

4-2-3 圧着規格

圧着規格については、適時弊社営業担当にお問い合わせ下さい。





<注意事項>

- ・圧着の際は、必ず規格内で圧着して下さい。規格外の場合、加縮部の固着力・電気抵抗が維持できず、製品の機能に支障をきたす恐れがあります。
- ・本内容については、弊社の圧着型を使用した場合に限りです。

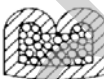
4-2-4 圧着時の注意事項と判定基準

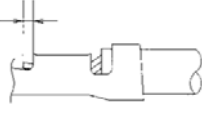
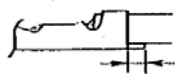
ターミナルの圧着には下記の項目について注意をし、重点管理をして下さい。

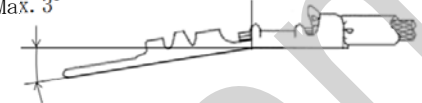
チェック項目	チェック内容	判定基準 (例)	原因と対策
ターミナル 圧着形状	導体ほつれがないかを見る。	○  ×ほつれは不可	圧着位置、導体のほつれ、クリンプ変形の確認修理
	導体圧着部バリがないかを見る。	○  × この面より出ている物は不可	クリンプワイドの幅、アンビルワイド摩耗の確認、交換
	ベルマウスの確認。	○ベルマウス部を残す ×Rのない物は不可	ターミナル送り位置、スペーサ、クリンプの位置確認、調整
	絶縁体下りがないかを見る。	○絶縁体はこの間にあること ×絶縁下りは不可	圧着位置確認、調整。 皮むき長さ確認
	絶縁体カシメがないかを見る。	○ ×前で絶縁体を圧着している物は不可	圧着位置確認、調整。 皮むき長さ確認

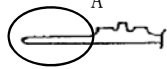
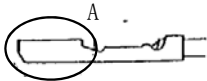
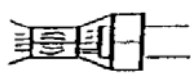
チェック項目	チェック内容	判定基準 (例)	原因と対策
ターミナル 圧着形状	芯線出すぎ、 芯線引込みが ないかを見る。	芯線出0~1mm  左図以外の 寸法は不可	圧着位置確認、 調整。 皮むき長さ確認
ターミナル つなぎ部 バリ	バリがないか を見る。	○ つなぎ長さ0~0.3mm 	切断位置、 シャープレードの 摩耗確認
上下方向 ターミナル 曲り	ターミナル曲り がないかを見る。	○ベンドアップ Max. 1°  ○ベンドダウン Max. 3° 	アンビル高さ、 変形確認
横方向 ターミナル 曲り	曲りがないか を見る。	 目視で変形が 認められるものは 使用できません。	アンビル、クリンプ 位置確認
ターミナル ねじれ	ねじれがないか を見る。	 目視でねじれの 確認できるものは 不可	ターミナル送り ガイド、クリンプ、 アンビル変形位置確認
ターミナル 変形	オスターミナル 右図A部分の 変形がないかを見る。	○  ×変形は不可	ターミナル送り面 クリンプ、 アンビル、変形、高さ 位置確認
	メスターミナル 右図A部分の 変形がないかを見る。	○  ×右図A部の変形 は不可	ターミナル送り面 クリンプ、 アンビル、変形、高さ 位置確認
圧着形状	導体見え	 ×導体が見えて は不可	ターミナルの 足の長さ、クリンプ、 ワイド確認

4-2-5 クリンプハイト、ワイドの測定方法

ターミナルと電線との固着力は適用電線毎に異り、その管理方法としてクリンプハイト（圧着高さ）の管理がある。

クリンプハイトは圧着されたターミナルの電氣的、機械的性能に影響するので、クリンプハイトが指定の寸法になっているか確認する。

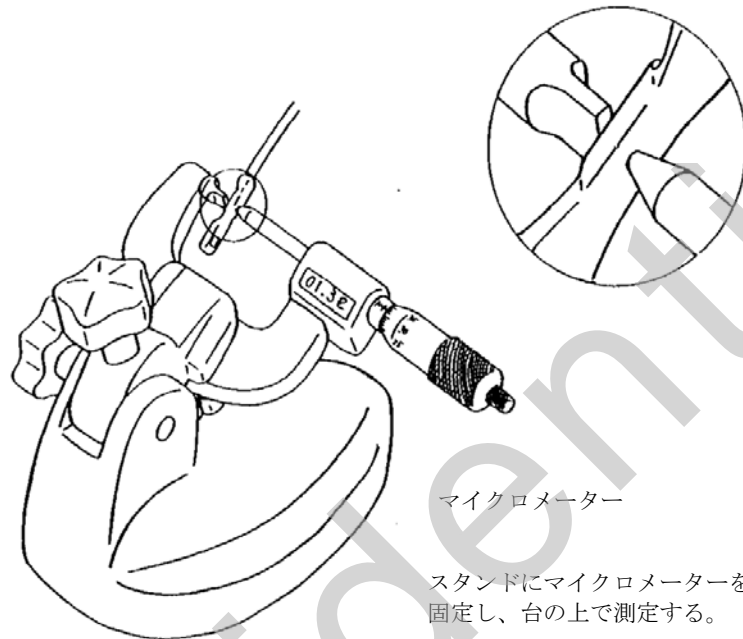

マイクロメーター

スタンドにマイクロメーターを固定し、台の上で測定する。

①クリンプハイトの測定方法

クリンプハイトは導体圧着部、絶縁体圧着部の中心を測定する。

②クリンプワイドの測定方法

クリンプワイドは導体圧着部、絶縁体圧着部下側の一番広い所を測定する。

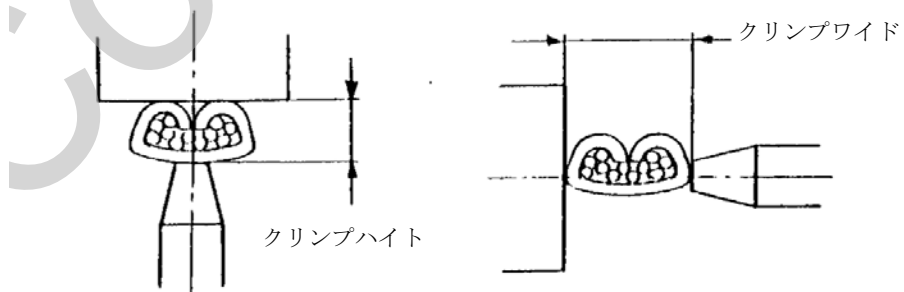

4-2-6 圧着後の確認事項

ターミナル圧着部強度（ターミナル・電線間）
約100 mmの長さの電線を圧着したターミナルを
固定し、電線を軸方向に約200 mm/minの一定
の速度で引張り、電線の破断あるいは圧着部
から電線の引き抜ける時の荷重を測定する。

測定方法

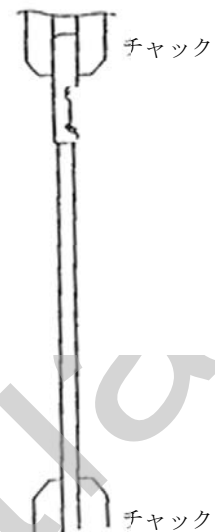

ターミナル圧着強度

電線サイズ(mm ²)	性能
0.2	68.6N 以上
0.3	78.4N 以上
0.5	88.2N 以上
0.85	127.4N 以上
1.25	176.4N 以上

4-3 ターミナル圧着後の製品取扱い

ターミナル圧着済品は、ターミナルの変形が発生しやすいため、運搬保管
には充分注意願います。

5. ハーネス製造作業

5-1 ハウジングへのターミナル挿入

- ①挿入は図の様な方向で挿入します。
- ②ターミナルの挿入は「パチン」という音がするまで確実に挿入します。
「パチン」と音がしたら軽く電線を引張り、確実に掛っていることを確認する。

オスコネクタ

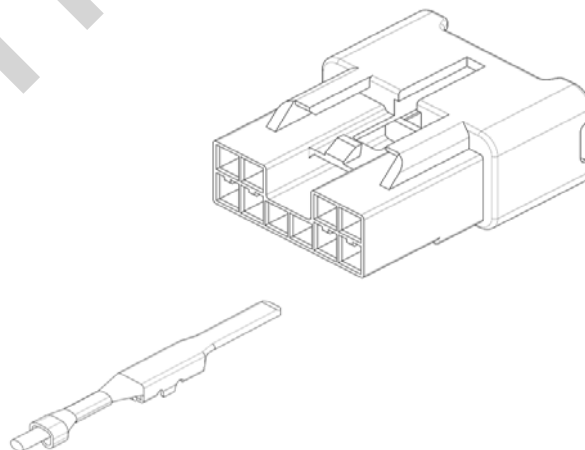

メスコネクタ

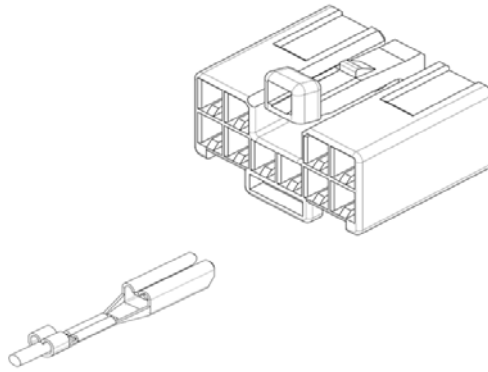

5-2 ターミナルの引き抜き

5-2-1 ターミナルの引き抜き治具

治具は矢崎部品1-08(49YA000078)を使用し、他の治具の使用は避けて下さい。

Confidential

5-2-2 ターミナルの引き抜き方

- ①ターミナルとハウジングランスの間隙に治具の先端をセットします。
- ②治具にてランスを図の様に曲げターミナルの係止孔よりピークを外し、電線を引張りターミナルを抜きます。
- ③誤って変形させたりした場合には、その多少に関係なく新しいものと交換して下さい。

オスコネクタ

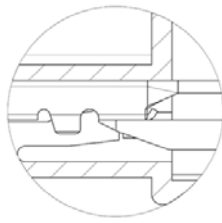
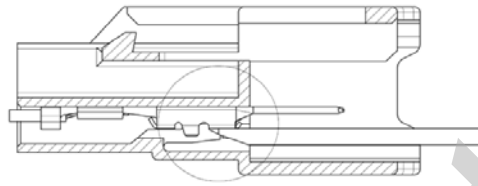

①

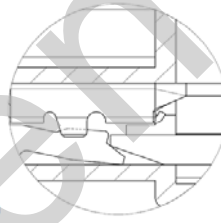

②

メスコネクタ

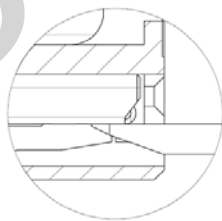
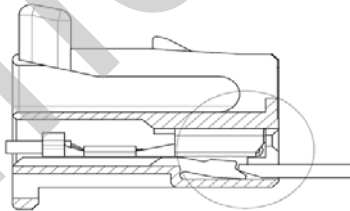

①

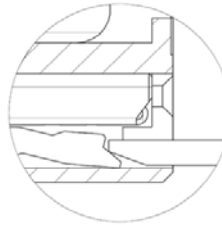

②

6. ハーネス製品の管理について

6-1 検査

- ①特定のターミナルに引張り荷重が加わらない様にテープ巻き等に注意して下さい。
- ②配線検査や導通検査に使用する治具は、コネクタがこじられない様に精度の高いガイドを設けて下さい。
- ③導通検査においてメス側に治具を挿入する時は、治具の精度をオスターミナルと同程度に管理して下さい。
- ④コネクタ、ターミナル共、変形や損傷が有った場合は、その多少に関係なく絶対に手直しを行なわないで、新しいものと交換して下さい。

6-2 出荷・運搬・保管

- ①塵芥、雨水等を防止し、丁寧に取扱う様に願います。

7. コネクタの嵌合及び取りはずし

7-1 コネクタの嵌合

- ①図の様にロッキングレバーとロッキングピットを同方向に合わせこじらない様に嵌合します。
- ②嵌合するときに、ロックを押さえた状態で嵌合すると、嵌合した時の「パチン」音が出ず半嵌合になりやすい為、ロックを押さえずに作業して下さい。
- ③ロックのかかるまで確実に挿入し、嵌合後は軽く引張ってロックがかかっている事を確認願います。

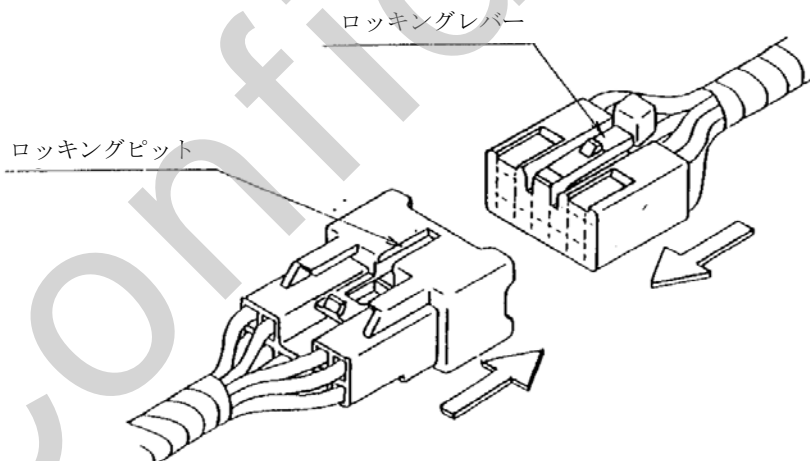

7-2 コネクタの取りはずし

- ① ロッキングキーを押してロックを解除してから、引張って取りはずして下さい。
- ② 電線を持って引張る事は避けて下さい。

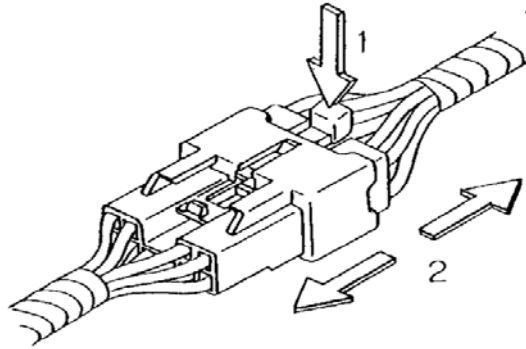





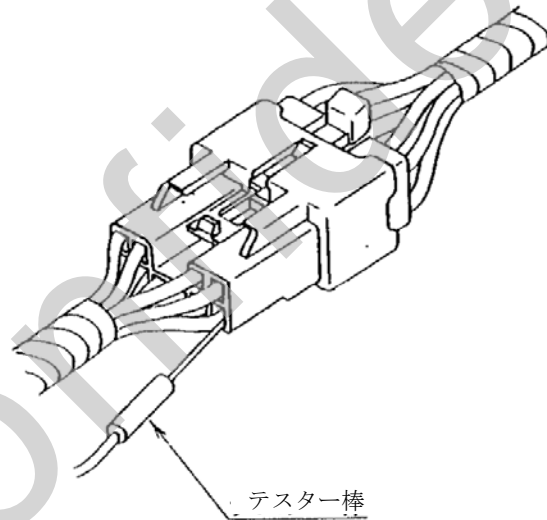







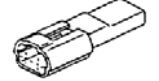
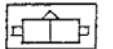

7-3 コネクタ嵌合後の回路チェック

テスター等で導通や電圧等を調べる時、テスター棒は必ず図の様に、電線側から差し込んで下さい。差し込めない場合には、同一の種類のコネクタを用意し、それを使用してチェックして下さい。

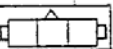

8. ターミナル及びハウジング一覧表 [I]

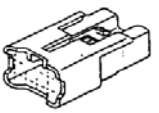
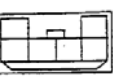
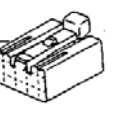
別紙-1

	オ ス					メ ス					備 考
	形 状	図示記号	トヨタ品番	矢崎品番	材質	形 状	図示記号	トヨタ品番	矢崎品番	材質	
ターミナル		—	90980-09071-A 90980-09083	7114-1170 7114-1171	黄 銅 Sn めっき		—	90980-09070 90980-09082	7116-1180 7116-1181	黄 銅 Sn めっき	
2 極	J/B	—						90980-10320-A	7123-1320 etc.	ナイロン	
セミロック 2 極			90980-10354	7122-1520 etc.	ナイロン			90980-10355	7123-1520 etc.	ナイロン	
3 極	J/B	—						90980-10420	7123-1431 etc.	ナイロン	
セミロック 3 極			90980-10364	7122-1430 etc.	ナイロン			90980-10365	7123-1430 etc.	ナイロン	
6 極			90980-10384	7122-1360 etc.	ナイロン			90980-10414	7123-1360 etc.	ナイロン	



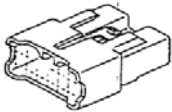
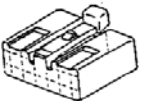
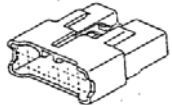
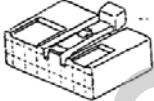
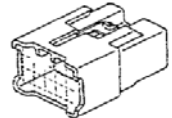
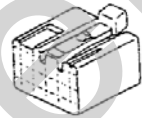
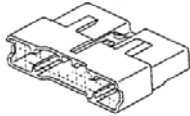
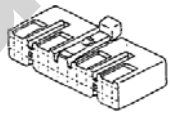
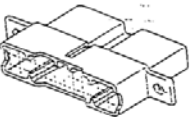
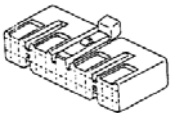
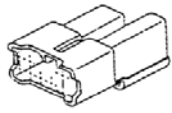
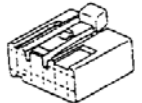

ターミナル及びハウジング一覧表 [II]

別紙-2

	オ ス					メ ス					備 考
	形 状	図示記号		矢崎品番	材質	形 状	図示記号		矢崎品番	材質	
10 極				7122-1300 etc.	ナイロン				7123-1300 etc.	ナイロン	
12 極				7122-1210 etc.	ナイロン				7123-1210 etc.	ナイロン	
13 極				7122-1330 etc.	ナイロン				7123-1330 etc.	ナイロン	
18 極				7122-1280 etc.	ナイロン				7123-1280 etc.	ナイロン	
18 極				7122-1281 etc.	ナイロン				7123-1280 etc.	ナイロン	
複合8極 090 6 + PA 2				7122-1481 etc.	ナイロン				7123-1481 etc.	ナイロン	

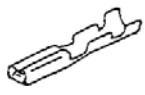
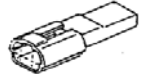



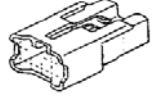
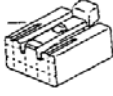
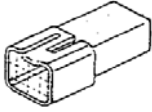
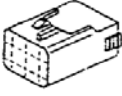
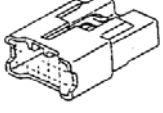
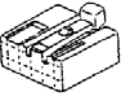





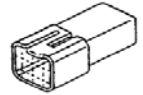

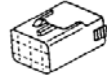
ターミナル及びハウジング一覧表 [IV]

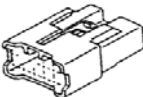
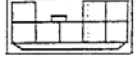
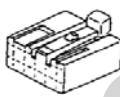
別紙-4

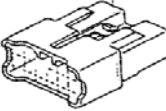
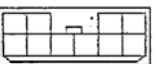
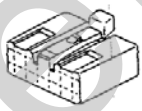
	オ ス					メ ス					備 考
	形 状	図示記号		矢崎品番	材質	形 状	図示記号		矢崎品番	材質	
ターミナル				7114-1170 7114-1171	黄 銅 Sn めっき				7116-1180 7116-1181	黄 銅 Sn めっき	
セミロック 2 極				7122-1520 etc.	ナイロン				7123-1520 etc.	ナイロン	
セミロック 3 極				7122-1430 etc.	ナイロン				7123-1430 etc.	ナイロン	
6 極				7122-1360 etc.	ナイロン				7123-1360 etc.	ナイロン	
セミロック 6 極				7122-1460 etc.	ナイロン				7123-1460 etc.	ナイロン	
8 極				7122-1480 etc.	ナイロン				7123-1480 etc.	ナイロン	

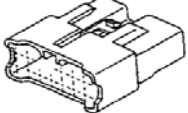
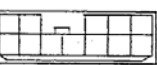
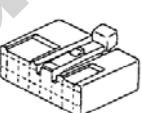

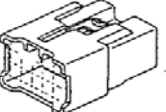
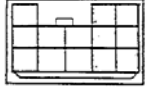
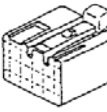
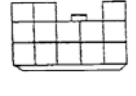
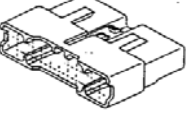

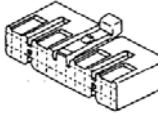
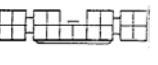

ターミナル及びハウジング一覧表 [V]

別紙-5

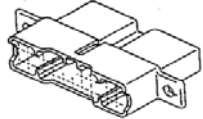
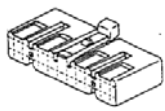
	オ ス					メ ス					備 考
	形 状	図示記号	トヨタ品番	矢崎品番	材質	形 状	図示記号	トヨタ品番	矢崎品番	材質	
セミロック 6 極			90980-10366	7122-1460 etc.	ナイロン			90980-10367	7123-1460 etc.	ナイロン	
8 極			90980-10360	7122-1480 etc.	ナイロン			90980-10321	7123-1480 etc.	ナイロン	
10 極			90980-10375	7122-1300 etc.	ナイロン			90980-10322	7123-1300 etc.	ナイロン	
12 極			_____	7122-1210 etc.	ナイロン			_____	7123-1210 etc.	ナイロン	
13 極			90980-10323	7122-1330 etc.	ナイロン			90980-10324-A	7123-1330 etc.	ナイロン	
18 極			90980-10325	7122-1280 etc.	ナイロン			90980-10326	7123-1280 etc.	ナイロン	

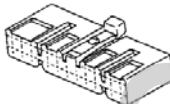
ターミナル及びハウジング一覧表 [VI]

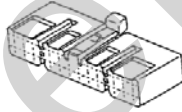
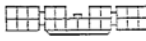
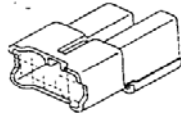
別紙-6

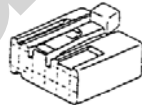
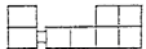
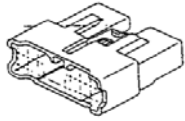
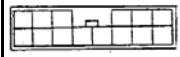
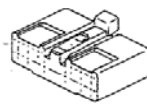
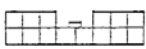
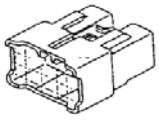
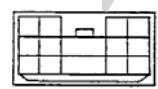
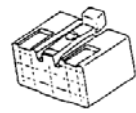
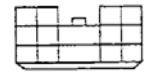
	オ ス					メ ス					備 考
	形 状	図示記号	トヨタ品番	矢崎品番	材質	形 状	図示記号	トヨタ品番	矢崎品番	材質	
18 極		—	90980-10413	7122-1281 etc.	ナイロン			90980-10326	7123-1280 etc.	ナイロン	
20 極	J/B	—						90980-10327	7123-1220 etc.	ナイロン	
22 極	J/B	—						90980-10328	7123-1420 etc.	ナイロン	
複合8極 090 6 + TODC 2			90980-10418	7122-1481 etc.	ナイロン			90980-10419	7123-1481 etc.	ナイロン	
複合12極 090 10 + 250 2			90980-10415	7122-1221 etc.	ナイロン			90980-10421	7123-1221 etc.	ナイロン	
複合14極 090 12 + 250 2			90980-10329	7122-1340 etc.	ナイロン			90980-10330	7123-1340 etc.	ナイロン	

YPES-15-042E

090 CONNECTOR
HANDLING MANUAL

Note)

This handling manual is subject to change without notice.
Please ask us for the latest version as necessary.

YAZAKI CORPORATION
YAZAKI PARTS LIMITED
May 28, 2018

Thank you for using our product.
This handling manual specifies the minimum requirements on using this product.
Please always observe all of these requirements when you handle this part.
We shall not be liable for any damage resulting from misuse or failure
to follow this handling manual.

Contents

- 1. About 090 Connector 2
- 2. Structure parts and each parts name 2
 - 2-1 Structure parts
 - 2-2 Each parts name
- 3. Inspection of terminal and housing 4
- 4. About crimping work 4
 - 4-1 Storage and transportation
 - 4-2 Crimping work
 - 4-3 Product handling after terminal crimping
- 5. Harness manufacturing work 8
 - 5-1 Terminal insertion in housing
 - 5-2 How to pull out terminal
- 6. About the management of harness product 11
 - 6-1 Inspection
 - 6-2 Shipment, transportation, storage
- 7. Mating and detaching of connector 11
 - 7-1 Mating of connector
 - 7-2 Detaching of connector
 - 7-3 Circuit check after connector mating
- 8. Terminal and housing table Attached sheet-1 to 7

1. About 090 connector

090 connectors are connectors developed deteriorating neither the performance, reliability nor the working efficiency compared with conventional parts as a purpose to attempt miniaturizing.

2. Structure parts and each parts name

2-1 Structure parts

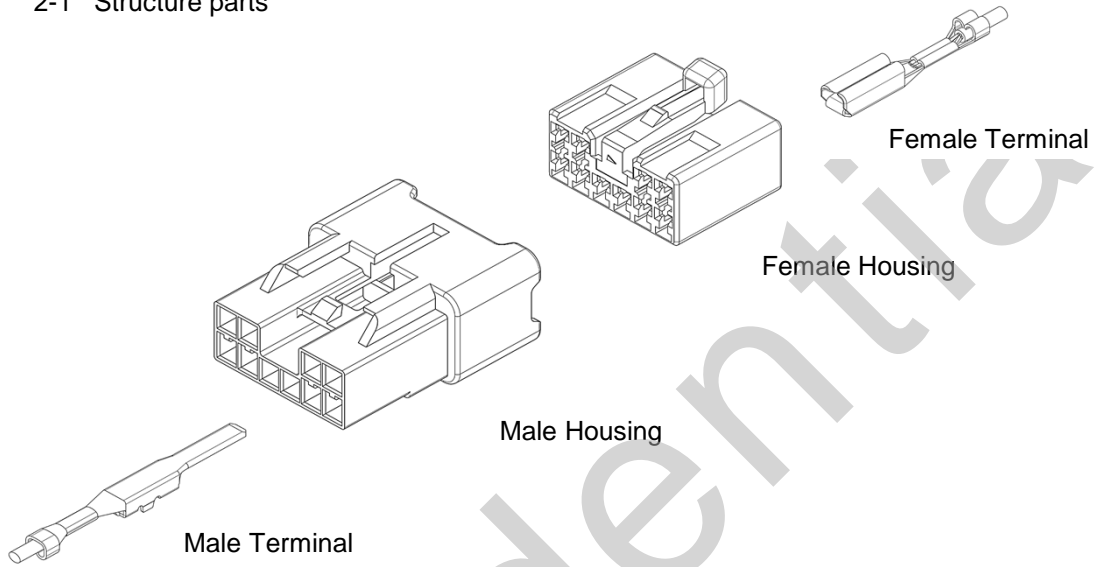

2-2 Each parts name

2-2-1 Male Terminal

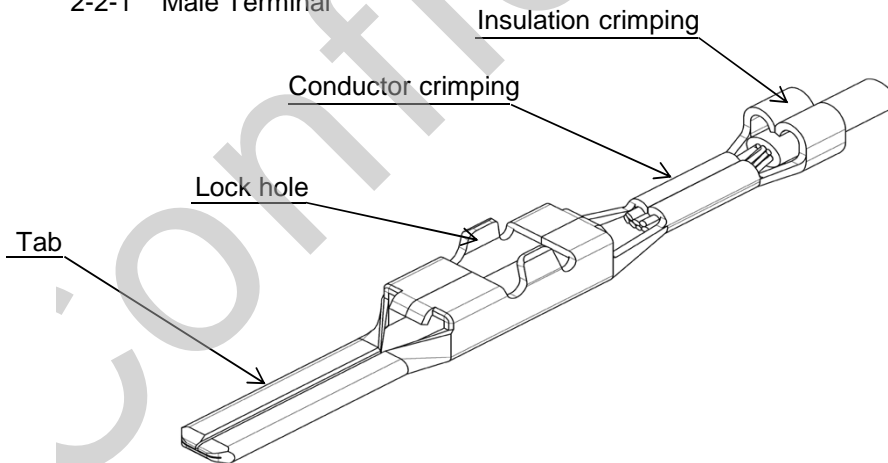

2-2-2 Female Terminal

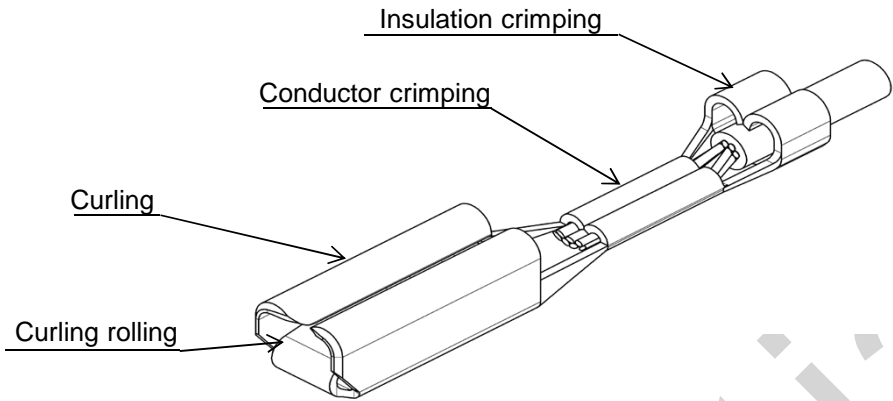

2-2-3 Male Housing

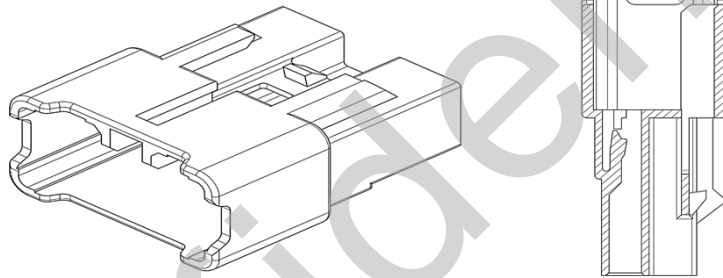

2-2-4 Female Housing

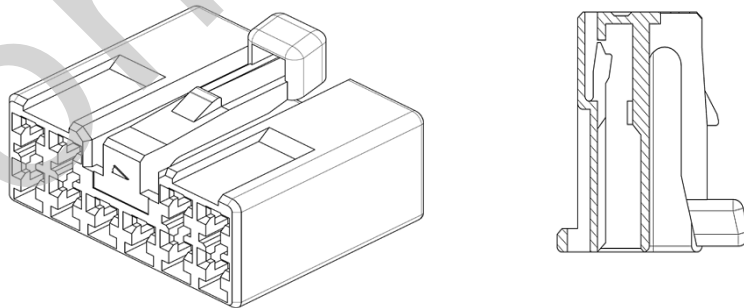

3. Inspection of terminal and housing

A complete inspection wants to be inspected the content of the drawing for the customer of the applicable product based on our company's inspection standard though already shipped.

4. About crimping work

4-1 Storage and transportation

- ① Please keep under a clean room and environment of normal temperature normal humidity (5~35°C, 45~85%RH) while put in packing box.
- ② Please have the metal part at the reel center, make the reel lengthways and transport when taking out of packing box and transporting.
- ③ Please connect the point with the flange with the wire etc. about the reel that discontinue the use so that the reel should not get loose.

4-2 Crimping work

4-2-1 Applicable wire

- ① Low-voltage cable for automobile JIS-C-3406
- ② Applies only to integral crimping of AVS 0.2 H, AVS -0.3, AVS 0.5, AVS 0.85, AVS 1.25 and equivalent products.

4-2-2 Notes

- ① Slanted cut-off

There must be no fraying of the conductor



- ② Conductor cut-off

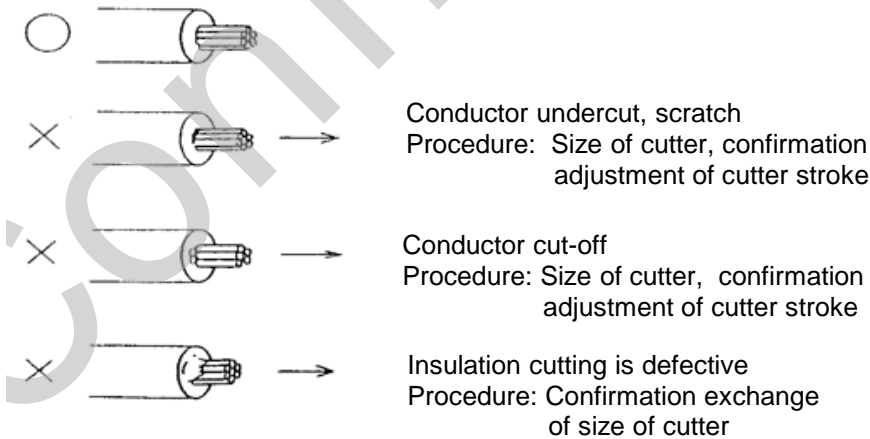

4-2-3 Crimping standard







For crimping standard, please contact our sales representative in a timely manner.



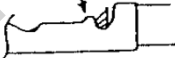
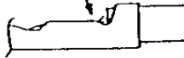
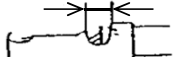

< Notes >

- When crimping, please make sure that it is within the standard. In case of non-standard, the fixing strength and electrical resistance of the crimping part cannot be maintained and it may interfere with product function.
- This content is limited only when our company's crimping tool is used.

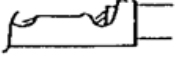
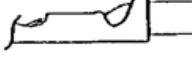
4-2-4 Notes and specific standards when crimping

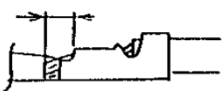
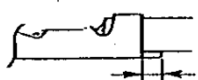
Please note and manage the important point of the following item in crimping of the terminal.

Check item	Content of check	Judgment standard (Example)	Cause and countermeasures
Terminal crimping shape	See whether there is conductor fraying.	○  × Fraying is improper. 	Confirmation repair of crimper deformation, fraying of conductor and crimping position.
	See whether there is conductor crimping burr.	○  ×  ↑ Thing that has gone out of this surface is improper.	Width of crimper wide and confirmation exchange of Anvil wide corrosion.
	Confirmation of Bell Mouth.	○ The bell mouth is left.  × Thing without P is improper. 	Adjustment and position confirmation of terminal sending position, spacer and crimper.
	See whether there is low insulation.	○ Meanwhile, there must be an insulation.  × Low insulation is improper. 	Crimping position confirmation, adjustment and stripping length confirmation.
	See whether there is insulation crimping	○  × Improper to do crimping in front of insulation 	Crimping position confirmation, adjustment and stripping length confirmation.

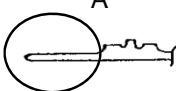
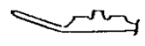
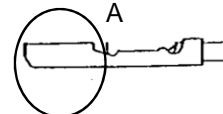
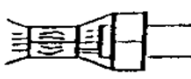
Check item	Content of check	Judgment standard (Example)	Cause and countermeasures
Terminal crimping shape	See whether there is core wire that goes out too much or no core wire withdrawn.	Core wire goes out 0~1mm  Dimension other than in left drawing are improper.	Ditto
Terminal connection burr	See whether there is no burr.	○ Tentative length 0~0.3mm 	Corrosion confirmation of cutting position and sharp blade
Bending in vertical direction terminal	See whether there is no bending in the terminal.	bend up Max. 1°  bend down Max. 3° 	Height of anvil and deformation confirmation.
Bending in side direction terminal	See whether there is no bending.	Any observable deformation by visual inspection is unacceptable 	Anvil and crimper position confirmation
Terminal twist	See whether there is no twist.	 The one that twist can be confirmed by visual is improper.	Terminal sending guide, crimper and Anvil deformation position.confirmation.
Terminal deformation	See whether the terminal male in right drawing A part is deformed.	○  × Deformation is improper. 	Terminal sending surface, crimper, Anvil, deformation and height position confirmation.
	See whether the terminal female in right drawing A part is deformed.	 Deformation of right drawing A part is improper.	Ditto
Crimping shape	Conductor is seen	 × Improper when the conductor is seen.	Crimper wide confirmation and length of foot of terminal

4-2-5 Measuring method of Crimp height and wide

Separation force of the terminal and wire is different in each applicable wire and crimp height (height of crimping) is controlled as the management method. It is confirm though crimp height becomes specified dimension because crimp height influences the electrical, mechanical performance of the terminal where crimping was done.

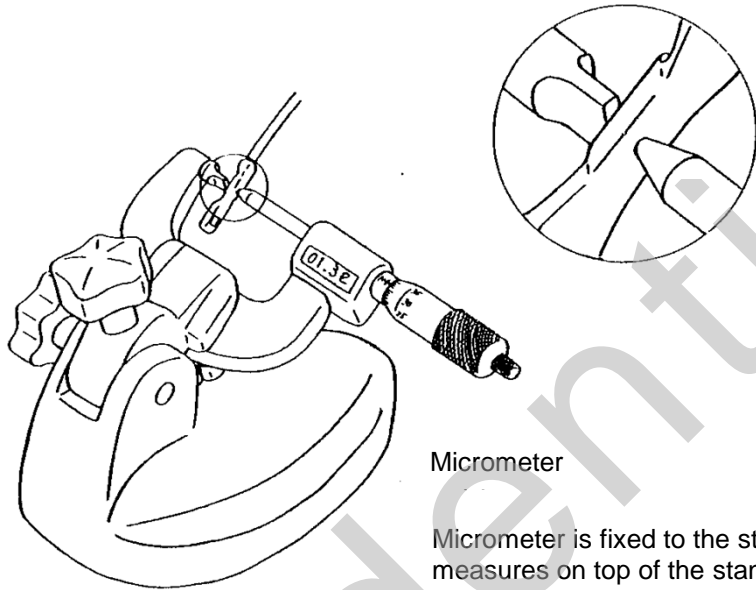

Micrometer

Micrometer is fixed to the stand and measures on top of the stand.

① Measuring method of crimp height

Crimp height measures the center of conductor crimping and insulation crimping.

② Measuring method of crimp width

Crimp width measures the widest place conductor crimping and under side insulation crimping.

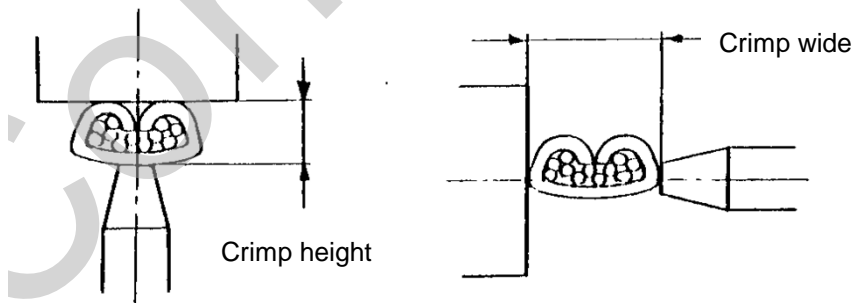

4-2-6 Confirmation item after crimping
 Terminal crimping strength (Between wires and terminals)
 The length of the wire of about 100mm is measured and the load where the terminal crimping can be fixed, when the wire is pulled axially at a constant speed of about 200mm/min, and when the wire is pulled out from breaking or crimping the wire is measured.

Terminal crimping strength

Wire size(mm ²)	Performance
0.2	68.6
0.3	78.4
0.5	88.2
0.85	127.4
1.25	176.4

(Unit : N Min.)

Measuring method

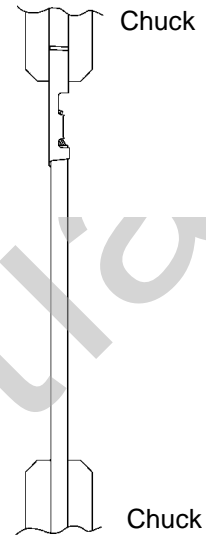

4-3 Product handling after terminal crimping
 Please take enough care when transporting and storing of finished terminal crimping products because deformation of terminal occurs easily.

5. Harness manufacturing work

5-1 Terminal insertion in housing

- ① Insertion is inserted in the direction like in the figure.
- ② The insertion of the terminal is surely inserted until the sound of「Pachin」 is heard. The wire is lightly pulled when the sound of 「Pachin」 is heard and confirm when it is surely hook.

Male Connector

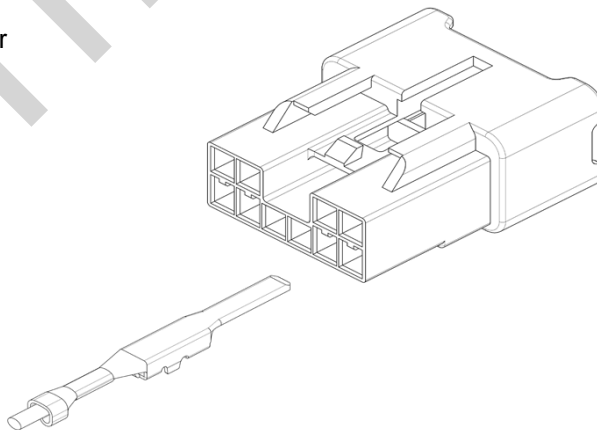

Female Connector

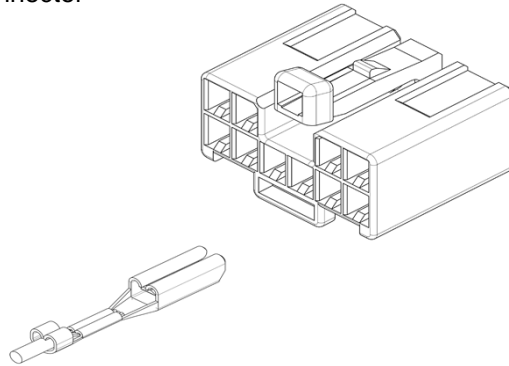

5-2 How to pull out terminal

5-2-1 Pulling tool of terminal

Please avoid the use of other tools by using
Yazaki parts number 1-08(49YA000078).

Confidential

5-2-2 How to pull out terminal

- ① The point of tool is set in the space between the terminal and the housing lance.
- ② Lance is pulled in tool and beak is removed from lock hole of the bend terminal as shown in figure, the wire is pulled and terminal is pull out.
- ③ Please exchange for a new one regardless of somewhat when deformed by mistake.

Male Connector

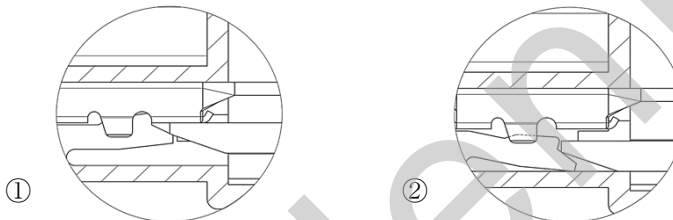
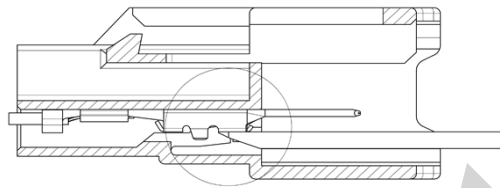

Female Connector

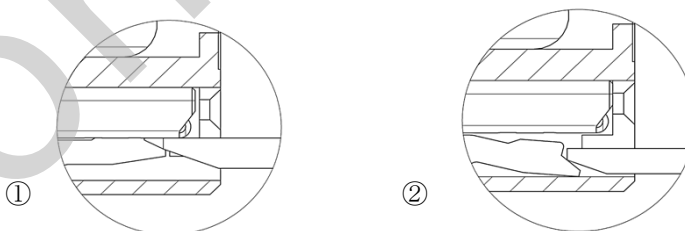
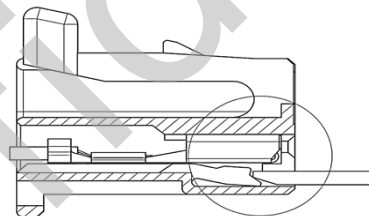

6. About the management of harness product

6-1 Inspection

- ① Please note the taping etc. so that the tension load should not join a specific terminal.
- ② Please install the guide with high accuracy so that connector should not become pry when tool is used for wiring inspection and conduction inspection.
- ③ Please control the accuracy of the tool to the same level of the male terminal when inserting tool in the female side on conduction inspection.
- ④ Please exchange for a new one and never modify regardless of somewhat when both connectors and terminals are deformed and damage.

6-2 Shipment, transportation, storage

- ① Please prevent from dust and rain water etc. and handle carefully.

7. Mating and detaching of connector

7-1 Mating of connector

- ① Locking lever and locking pit are set to the same direction and mating is done so as not to pry as shown in figure.
- ② Please work without suppressing the lock because partial mating becomes easy when the sound of 「Pachin」 comes out and when mating is done with the lock suppressed the mating is done.
- ③ Please confirm the insertion surely until it locked and pull lightly if lock is locked after mating.

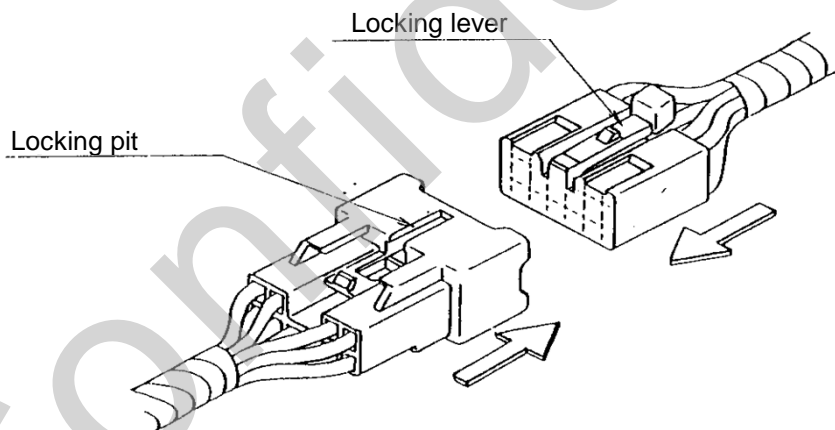

7-2 Detaching of connector

- ① Please pull and detach after releasing lock by pushing the lock key.
- ② Please avoid pulling the wire while holding.

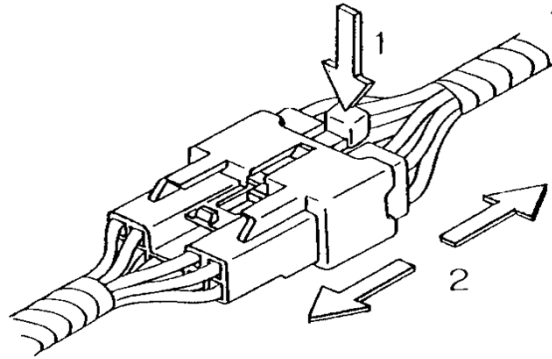





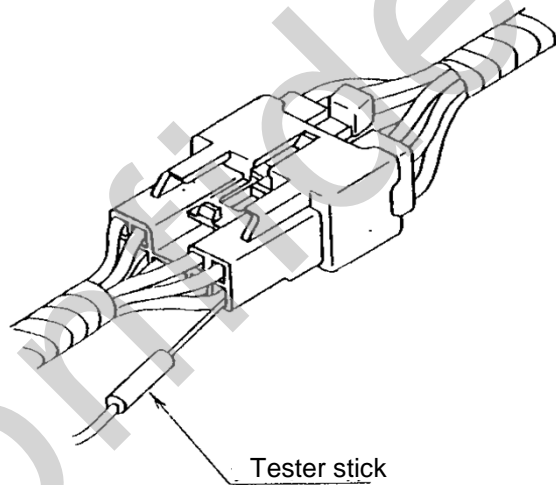

7-3 Circuit check after connector mating

Please insert the tester stick from the wire side as shown in figure when examining the conductor and voltage, etc. with the tester etc. Please check by preparing the same kind of connector and use when not possible to insert.

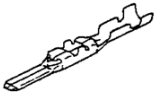
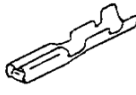
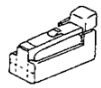

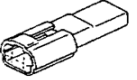
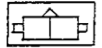

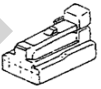
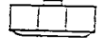
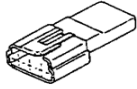
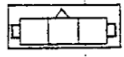

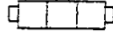
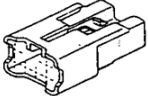
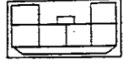
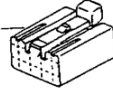
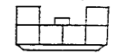
8. Terminal and housing table [I]

Attached sheet-1

	Male					Female					Remarks
	Shape	Code shown	Toyota Parts No.	Yazaki Parts No.	Material	Shape	Code shown	Toyota Parts No.	Yazaki Parts No.	Material	
Terminal		_____	90980-09071-A 90980-09083	7114-1170 7114-1171	Brass Sn plating		_____	90980-09070 90980-09082	7116-1180 7116-1181	Brass Sn Plating	
2 Poles	J/B	_____						90980-10320-A	7123-1320 etc.	Nylon	
Semi-lock 2 Poles			90980-10354	7122-1520 etc.	Nylon			90980-10355	7123-1520 etc.	Nylon	
3 Poles	J/B	_____						90980-10420	7123-1431 etc.	Nylon	
Semi-lock 3 Poles			90980-10364	7122-1430 etc.	Nylon			90980-10365	7123-1430 etc.	Nylon	
6 Poles			90980-10384	7122-1360 etc.	Nylon			90980-10414	7123-1360 etc.	Nylon	

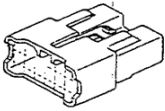
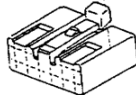
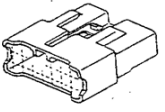
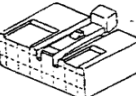
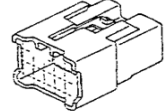
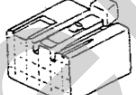

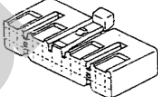

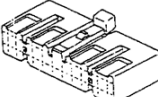
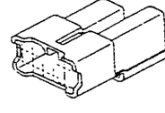
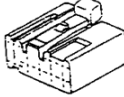

Terminal and housing table [II]

Attached sheet-2

	Male					Female					Remarks
	Shape	Code shown	Toyota Parts No.	Yazaki Parts No.	Material	Shape	Code shown	Toyota Parts No.	Yazaki Parts No.	Material	
10 Poles				7122-1300 etc.	Nylon				7123-1300 etc.	Nylon	
12 Poles				7122-1210 etc.	Nylon				7123-1210 etc.	Nylon	
13 Poles				7122-1330 etc.	Nylon				7123-1330 etc.	Nylon	
18 Poles				7122-1280 etc.	Nylon				7123-1280 etc.	Nylon	
18 Poles				7122-1281 etc.	Nylon				7123-1280 etc.	Nylon	
Multiple 8 Poles 090 10 + PA 2				7122-1481 etc.	Nylon				7123-1481 etc.	Nylon	

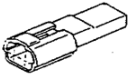

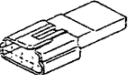

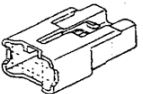
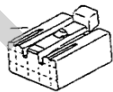
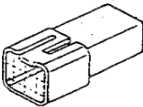
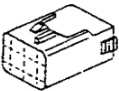
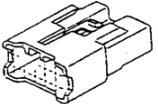
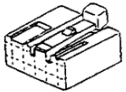

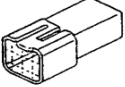

8. Terminal and housing table [IV]

Attached sheet-4

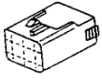
	Male					Female					Remarks
	Shape	Code shown		Yazaki Parts No.	Material	Shape	Code shown		Yazaki Parts No.	Material	
Terminal				7114-1170 7114-1171	Brass Sn Plating				7116-1180 7116-1181	Brass Sn Plating	
Semi-lock 2 Poles				7122-1520 etc.	Nylon				7123-1520 etc.	Nylon	
Semi-lock 3 Poles				7122-1430 etc.	Nylon				7123-1430 etc.	Nylon	
6 Poles				7122-1360 etc.	Nylon				7123-1360 etc.	Nylon	
Semi-lock 6 Poles				7122-1460 etc.	Nylon				7123-1460 etc.	Nylon	
8 Poles				7122-1480 etc.	Nylon				7123-1480 etc.	Nylon	

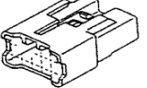
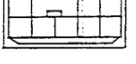
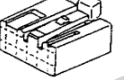

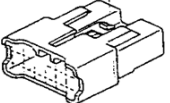
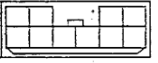
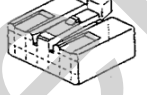

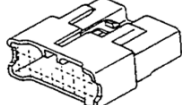
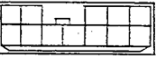
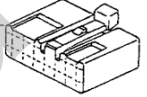
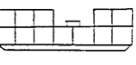
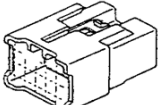
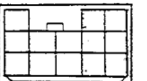
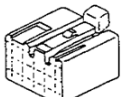
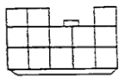
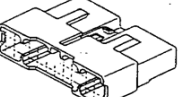
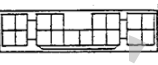
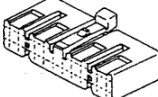
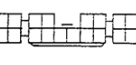
Terminal and housing table [V]

Attached sheet-5

	Male					Female					Remarks
	Shape	Code shown	Toyota Parts No.	Yazaki Parts No.	Material	Shape	Code shown	Toyota Parts No.	Yazaki Parts No.	Material	
Semi-lock 6 Poles			90980-10366	7122-1460 etc.	Nylon			90980-10367	7123-1460 etc.	Nylon	
8 Poles			90980-10360	7122-1480 etc.	Nylon			90980-10321	7123-1480 etc.	Nylon	
10 Poles			90980-10375	7122-1300 etc.	Nylon			90980-10322	7123-1300 etc.	Nylon	
12 Poles			_____	7122-1210 etc.	Nylon			_____	7123-1210 etc.	Nylon	
13 Poles			90980-10323	7122-1330 etc.	Nylon			90980-10324-A	7123-1330 etc.	Nylon	
18 Poles			90980-10325	7122-1280 etc.	Nylon			90980-10326	7123-1280 etc.	Nylon	

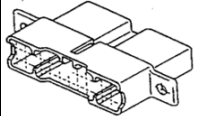
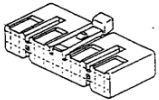
Terminal and housing table [VI]

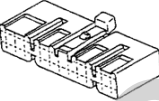
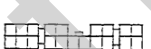
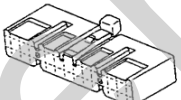
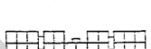
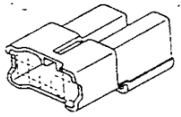
Attached sheet-6

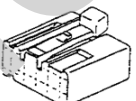
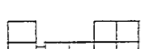
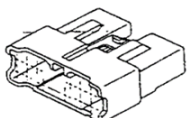
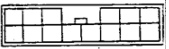
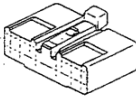
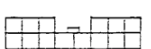
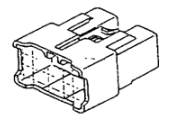
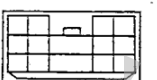
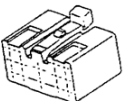
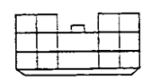
	Male					Female					Remarks
	Shape	Code shown	Toyota Parts No.	Yazaki Parts No.	Material	Shape	Code shown	Toyota Parts No.	Yazaki Parts No.	Material	
18 Poles		_____	90980-10413	7122-1281 etc.	Nylon			90980-10326	7123-1280 etc.	Nylon	
20 Poles	J/B	_____						90980-10327	7123-1220 etc.	Nylon	
22 Poles	J/B	_____						90980-10328	7123-1420 etc.	Nylon	
Multiple 8 Poles 090 6 + TODC 2			90980-10418	7122-1481 etc.	Nylon			90980-10419	7123-1481 etc.	Nylon	
Multiple 12 Poles 090 10 + 250 2			90980-10415	7122-1221 etc.	Nylon			90980-10421	7123-1221 etc.	Nylon	
Multiple 14 Poles 090 12 + 250 2			90980-10329	7122-1340 etc.	Nylon			90980-10330	7123-1340 etc.	Nylon	

