

Handling Manual  
of  
A/B Squib Connector

<NOTE>

Please be informed that the contents in this handling manual may be revised without any notice.

## INDEX

1.	Summary .....	3
2.	Component Structure .....	5
3.	Component List .....	6
4.	Parts Inspection .....	10
5.	Storage and Transportation .....	11
6.	Crimping Specification .....	12
7.	Handling of Crimped Terminals .....	16
8.	Set-Up Methods (Terminals, Spacer, Boots, Dust-Proof covers) .....	17
9.	Removal of Terminals, Spacers, Dust-Proof Covers .....	22
10.	W/H Assembly Precautions .....	25
11.	Methods of Mating and Removing Dual Lock Connector .....	26

## 1. SUMMARY

- 1-1 A/B Squib connectors are used for the airbag circuit of vehicles. To increase durability, the terminals are plated in gold. Moreover, to insert terminals and connectors correctly, double lock and dual lock systems (male housing) are used, and automatic shortage between terminals is built in male housing to prevent misfire of airbag.

The mechanics of double lock system is that already present spacers are pushed in after the terminals are inserted. The mechanics of dual lock system is that male and female connectors are locked by another locking function after the mating.

Automatic shortage between terminals has the mechanics that shortens between terminals automatically in order to prevent misfire of airbag caused by static electricity.

### 1-2 Airbag Parts No.

In order to convert from current airbag W/H connectors, components, part numbers, and new part numbers, the following table should be used. (Note: only the second position has been changed.)

PRESENT PART NO.	AIRBAG PART NO.
70** - *****	7A** - *****
71** - *****	7B** - *****
72** - *****	7C** - *****
73** - *****	7D** - *****

Used airbag part no. for airbag W/H

Prior to the usage of A/B Squib connectors, read this handling manual and handle with care.

1-3 The Mechanics of Essential Systems

1) Dual Lock System

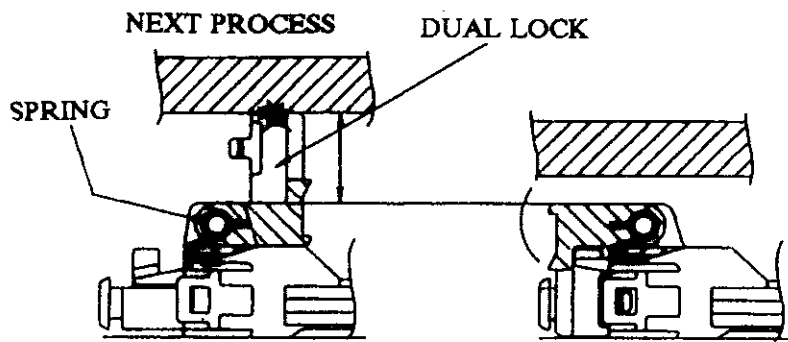

Dual lock will interfere with the following process if improper size parts are used, because it stands perpendicular by the spring. This feature will prevent operator from having a bad connection pass the check stand.

2) Short Spacing

CONNECTOR MATED

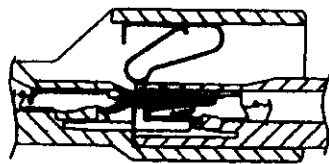

CONNECTOR REMATED

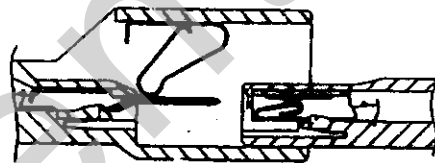

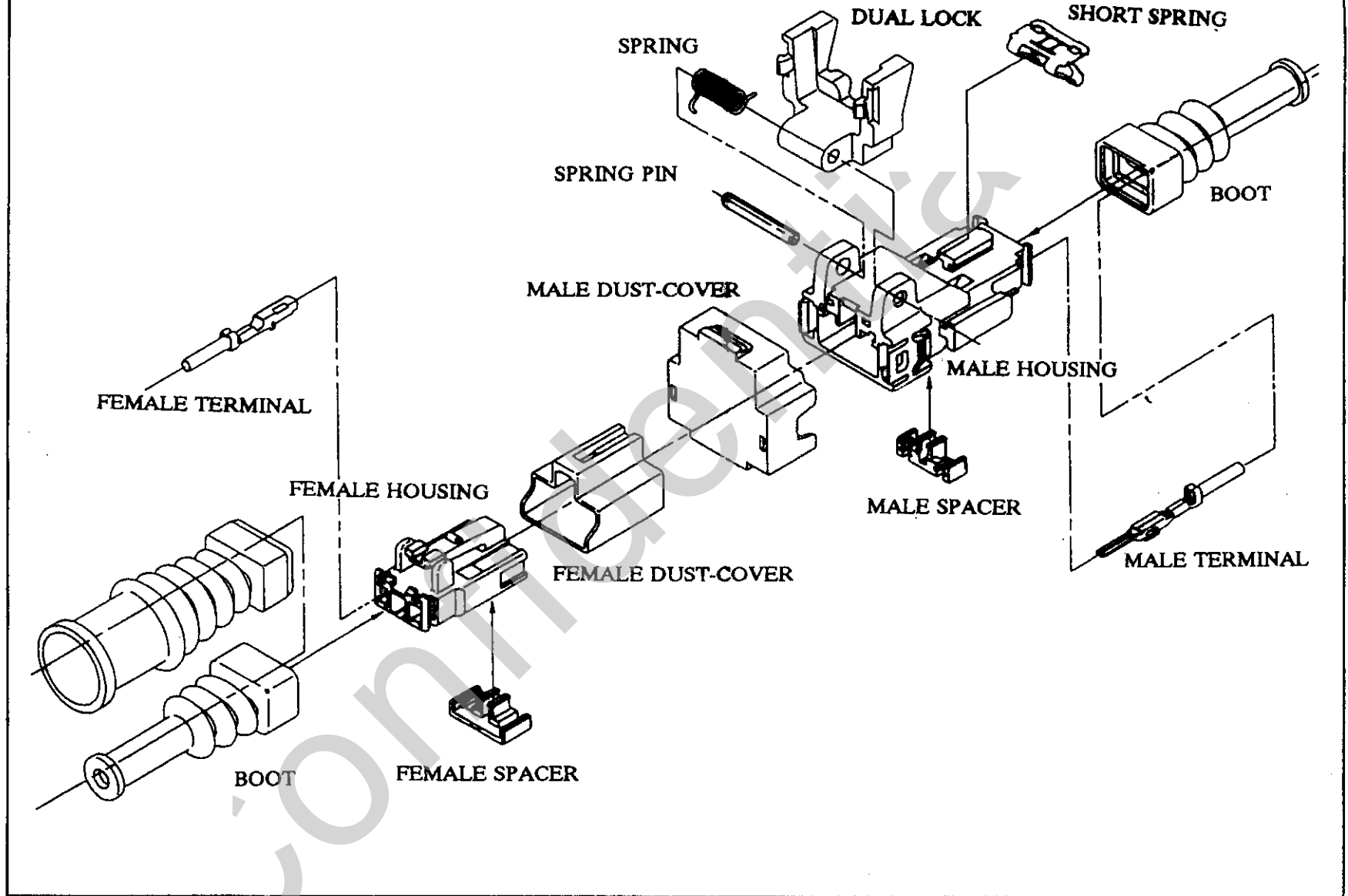

With the connector mated, the female connector pushes the short spring up. By removing the female connector, the spring goes back to the normal position and touches two male terminals. As a result, the distance between terminals is shortened. These actions prevent misfire which can occur from the current caused by static electricity between terminals.

2. COMPONENT STRUCTURE

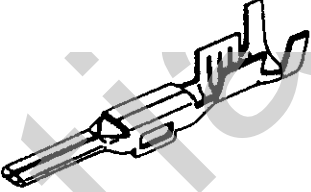

3. COMPONENT LIST

A/B Terminal

TOYOTA NUMBER	YAZAKI NUMBER	YAZAKI NAME	CONFIGURATION	MATERIAL	REMARK
90980-09315-A	7B14-1447	A/B Terminal M (090II)		c2600 t=0.30 Ni plating Partial Au plating Sn plating	
90980-09316	7B16-1460	A/B Terminal F (090II)		c2600 t=0.25 Ni plating Partial Au plating Sn plating	

A/B Male Housing

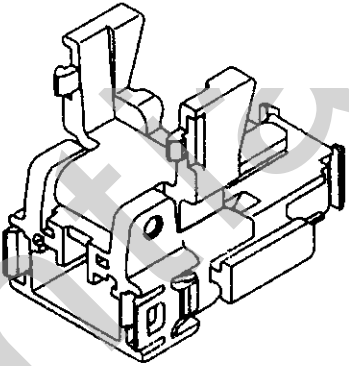
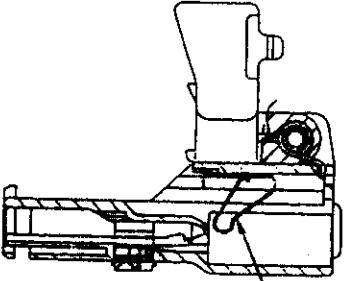
TOYOTA NUMBER	YAZAKI NUMBER	YAZAKI NAME	CONFIGURATION	MATERIAL	REMARK
90980-10849	7C82-1822-70	A/B Connector Housing 2PM-S (Sub Assy.)	   <p data-bbox="1458 1193 1637 1230">Short Spring</p>	<p data-bbox="1666 671 1778 778">PBT Color: Yellow</p> <p data-bbox="1666 858 1845 1082">Short Spring C5210 t=0.30 Ni Plating Partial Au Plating</p>	

A/B Female Housing

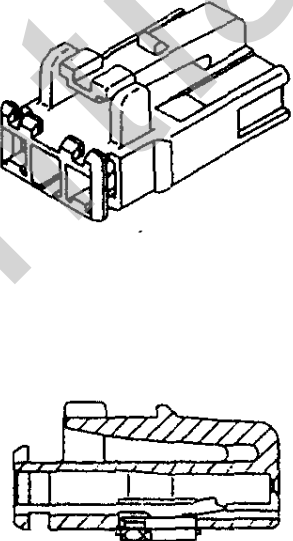
TOYOTA NUMBER	YAZAKI NUMBER	YAZAKI NAME	CONFIGURATION	MATERIAL	REMARK
90980-10850	7C83-1822-70	A/B Connector Housing 2PF-S (Sub Assy.)		PBT Color: Yellow	

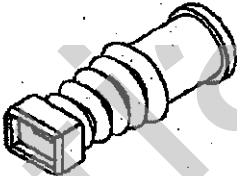
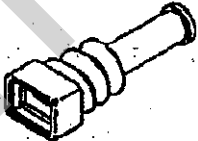
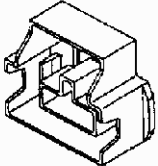
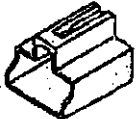
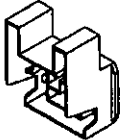

A/B Boot, Dust-Cover

TOYOTA NUMBER	YAZAKI NUMBER	YAZAKI NAME	CONFIGURATION	MATERIAL	REMARK
82821-50110	7134-2626	A/B Boot 2PF-S		EPDM Color: Black	
82821-50190	7134-2702	A/B Boot 2P-S		EPDM Color: Black	
82821-50170	7134-4290	A/B Cover 2PM-S		P.P Color: Natural	
82821-50180	7134-2635	A/B Cover 2PF-S		P.P Color: Natural	
82821-30480	7134-2991	A/B Cover 2PM-S		P.P Color: Natural	

#### 4. PARTS INSPECTION

##### 4-1 Inspection at Shipping

The inspection that complies with each specification and the complete control by lot number has been done. As a rule, the manufactured date (lot number) will be indicated on each package. The history of the parts in the manufacturing process, such as material lot, manufacturing condition, record, inspection record, etc., can be pursued by lot number. The way of indicating lot number is as follows:

##### PRESS PARTS (TERMINALS, ETC.)

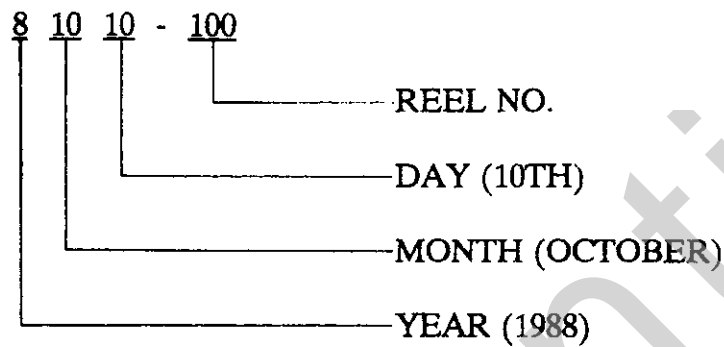

##### NON-PRESS PARTS (HOUSINGS, PACKING, ETC.)

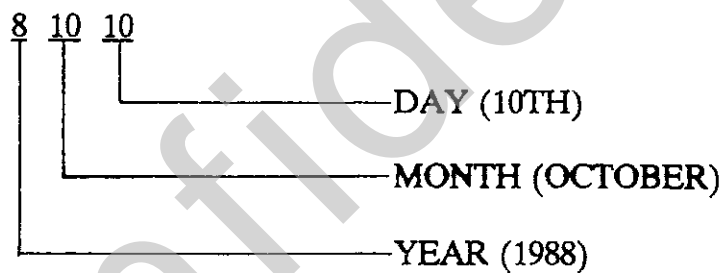

## 5. STORAGE AND TRANSPORTATION

For storing and transporting each part, follow these regulations to deformation, breakage, dirt, etc.

### 1) Terminals

1. As to the storage and transportation of terminal reel, follow the illustration below:

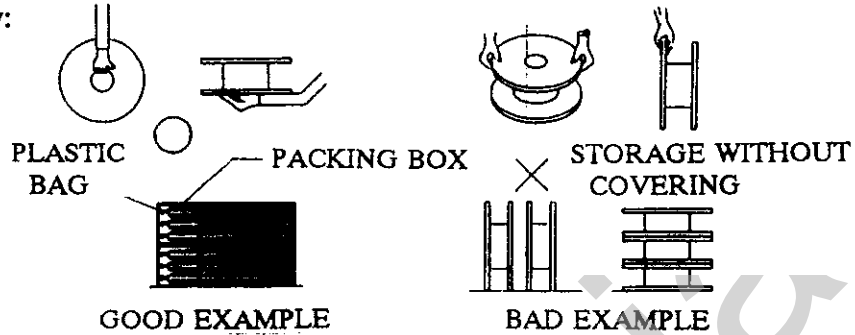

2. Store in clean room with constant temperature, low humidity, and no direct sunlight.
3. Do not store without packing box or plastic bags.  
(Protect them especially from water, oil, dirt, etc.)
4. If use of terminals is stopped at mid-point and the rest will be stored, secure terminal to the frame of the reel so terminal will not become unwound.

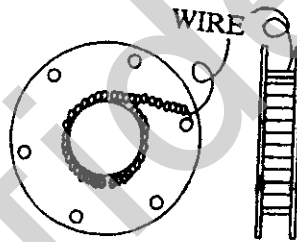

5. Take great care in transporting and storing; do not drop from heights or give any shocks.
- ### 2) Housing (including spacers)

1. Avoid external force during storage.
2. Store in clean room with constant temperature, low humidity, and no direct sunlight.
3. Do not store without packing box or plastic bags.  
(Protect them especially from water, oil, dirt, etc.)
4. Take great care in transporting and storing not to drop from heights or give any shocks.

6. CRIMPING SPECIFICATION

Refer to crimping specification table of separate publication. Be sure to crimp within the specification. Crimping out of specification may affect the performance of the products, since it cannot maintain wire pull off force with terminal and electric resistance value.

6-1 Applicable Wire

No.	DESIGNATION	SYMBOL	SIZE
1	Cross-linked vinyl chloride Insulated heat resistant Low Voltage cable for air bag	ABAVX (Sn Plate)	0.5f, 0.75f
2	Cross-linked vinyl chloride Insulated heat resistant Low voltage cable for automotive	ACFAVX	0.75f
3	Cross-linked polyethylene chloride Insulated heat resistant Low voltage cable for automotive	ACFAEX	0.75f

6-2 The measuring points of crimped area  
(Set up C/H and C/W at the median of the specification.)

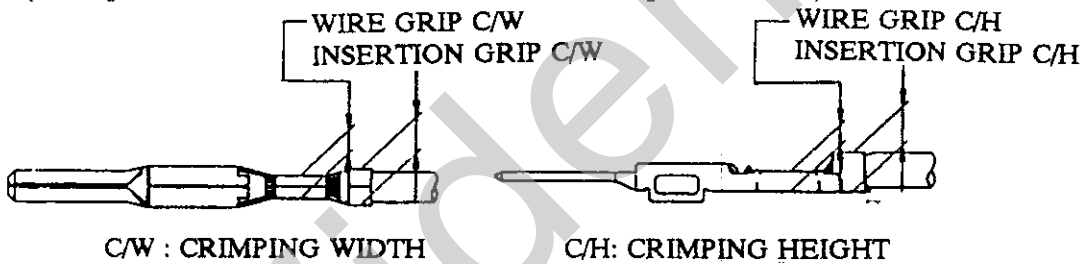

6-3 The method of measuring crimping height and crimping width.  
Measure the centers of crimped wire grip and crimped insulation grip with micrometer.

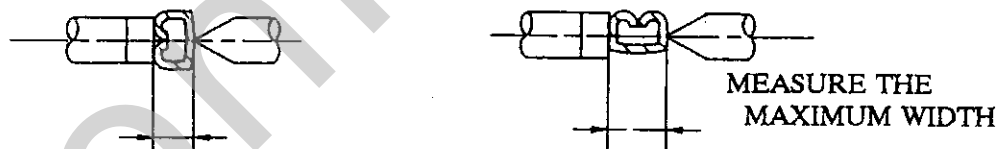

FOR MEASURING CRIMPING HEIGHT      FOR MEASURING CRIMPING WIDTH

6-4 Measuring Device

Used micrometers fixed to stands.

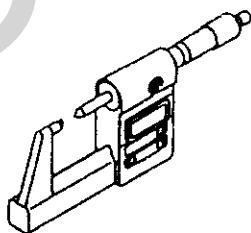

6-5 Checkpoint and judgement standard of crimping



- Crimping shall be carefully controlled, considering the following.
- When crimping, do not touch gold plating portion of terminal.
- If crimped terminals are to be stored without connector inserted, wrap crimped terminal with vinyl sack, etc., to prevent any possible damage.

	CHECK POINT	JUDGEMENT STANDARD
1. Wire	1) Oblique conductor cutting 2) Conductor 3) Oblique insulation cutting 4) Insulation insufficient cutting	<p>             NORMAL      CONDUCTOR OBLIQUE CUTTING      CONDUCTOR FRAGMENT              INSULATION OBLIQUE CUTTING      INSULATION INSUFFICIENT CUTTING           </p>
2. Conductor Grip Portion	Normal	
	1) Conductor Ravel	
	2) Bell mouth must remain in normal shape	
	3) High insulation crimping	

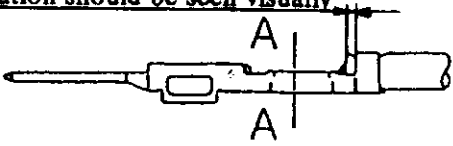
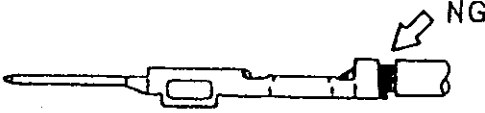
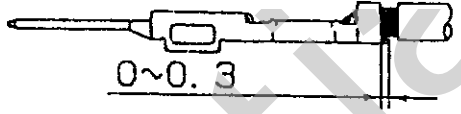
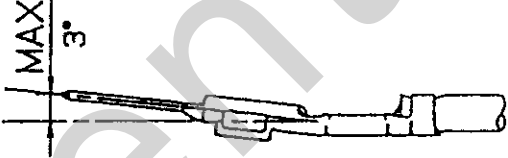
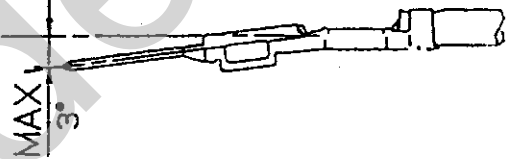
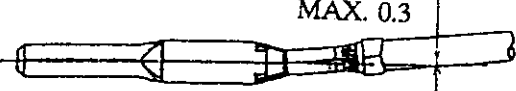
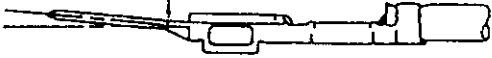
\* MALE/FEMALE IN COMMON

	CHECK POINT		JUDGEMENT STANDARD
3. Insulation Grip Portion	Normal		<u>Insulation should be seen visually</u>  *
	1) Low insulation crimping		 *
	2) Cut off tab		 *
4. Deformation	1) Vertical Direction	Bend Up	 *
		Bend Down	 *
	2) Horizontal Direction		 *
	3) Tab Deformation		No Bend From This Point, Visually 

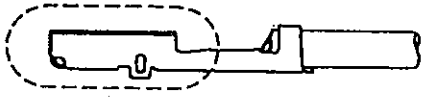
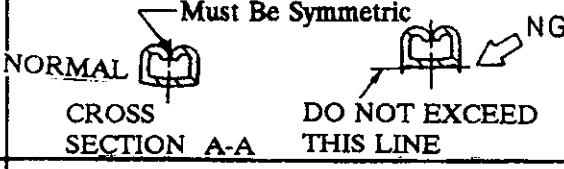
\* MALE/FEMALE IN COMMON

	CHECK POINT	JUDGEMENT STANDARD
4. Deformation (cont.)	4) Box Deformation	 <p>This portion should not be deformed</p>
	5) Burr	<p>Must Be Symmetric</p>  <p>NORMAL CROSS SECTION A-A</p> <p>DO NOT EXCEED THIS LINE</p>
	6) Twisting	 <p>NO TWISTING</p>

\* Male/Female in common

## 7. HANDLING OF CRIMPED TERMINALS

It is recommended that crimped terminals be used relatively soon. Since the crimped terminals are easily deformed (bent, crushed) during transportation and storage, care should be taken with the following items:

- 1) The number of crimped terminal wires in a bundle should be 50-100. They should be bundled with elastic bands soon. Excess numbers of crimped wires may cause entanglement and make handling difficult.
- 2) After crimping terminals, wrap them with plastic bags to protect, and keep them wrapped during transportation and storage until assembly.
- 3) Use sub-assembly wire moveable handle or poly-container for the transportation of crimped wire. Do not stack; it should have the least burden for wire and terminals.
- 4) Sub-assembly should be handled carefully at all times.

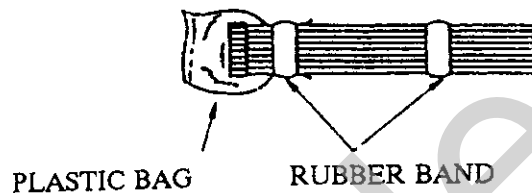

<THE EXAMPLE OF HANDLING CRIMPED WIRE>

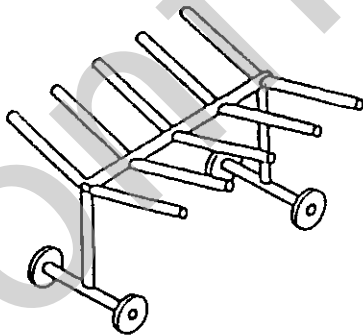

<SUB-ASSEMBLY WIRE MOVABLE HANGER>

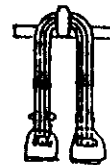

<SHORT>

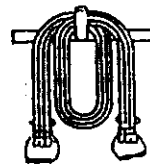

<LONG>



## 8. SET-UP METHODS (TERMINAL, SPACER, BOOT, DUST-PROOF COVER)

### 8-1 Terminal Insertion

#### 1) Male Terminal

Insertion of male terminal must conform to following method in order to avoid hitting and damaging short spring or terminal by the point of male terminal.

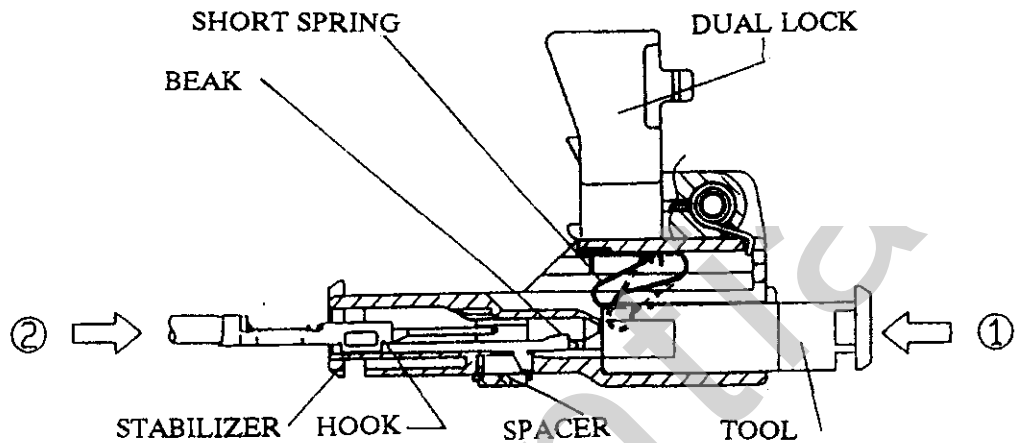

1. Female housing or equivalent tool to be connected to male housing.
2. Terminal stabilizer must face opposite to dual lock. Insert straight, without wrenching (see above picture).
3. For proper insertion, hook should be completely inserted and lock to the beak with a "click".
4. Pull wire slightly and make sure beak is completely locked on the hook.
5. Remove female housing or equivalent tool.
6. Insert spacer (5. & 6. can be reversed).
7. Confirm that male terminal and short spring are contact by circuit check.

#### **PRECAUTION**

- Procedure 1 must be carried out first, so that short spring will not be damaged.
- If the female housing is used as a tool, shave off the projection of lock. If other tools are used, make sure there are no scratches on surface of short spring, and no deformities.
- Do not touch gold plated point (mating point) of terminal.

- Make sure there is no dirt or strings stuck on terminal.
- This process must be done in a clean environment where there is no possibility of putting dirt or other substance between short spring and male terminal.
- When terminal insertion is very stiff, check the inserting direction and the locking condition of spacer, since terminal may be inserted in reverse direction, or spacer might have been locked.

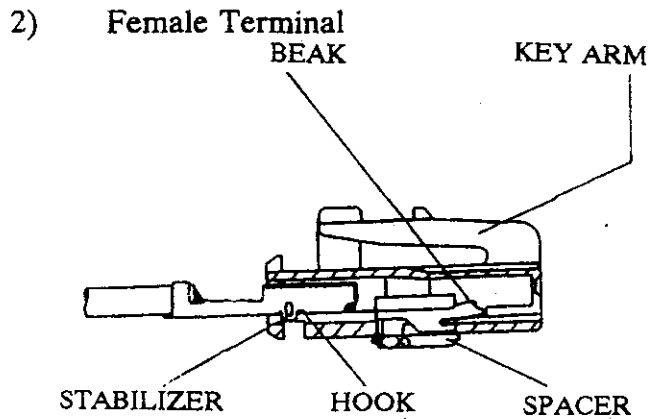

1. Terminal stabilizer must face opposite to key arm and be inserted straight with no wrenching.
2. Upon insertion, beak should lock to the hook with a "click."
3. Pull wire slightly and make sure it is completely locked on the hook.
4. Insert spacer.

**PRECAUTION**

- Do not touch gold plated point (mating point) of terminal.
- Make sure there is no dirt or strings stuck on terminal.
- When terminal insertion is stiff, check the insertion direction and the locking condition of spacer, since terminal may be inserted in reverse direction, or spacer might have been locked.

## 8-2 Spacer Insertion (male/female in common)

To prevent terminal push-outs, terminal must be double locked

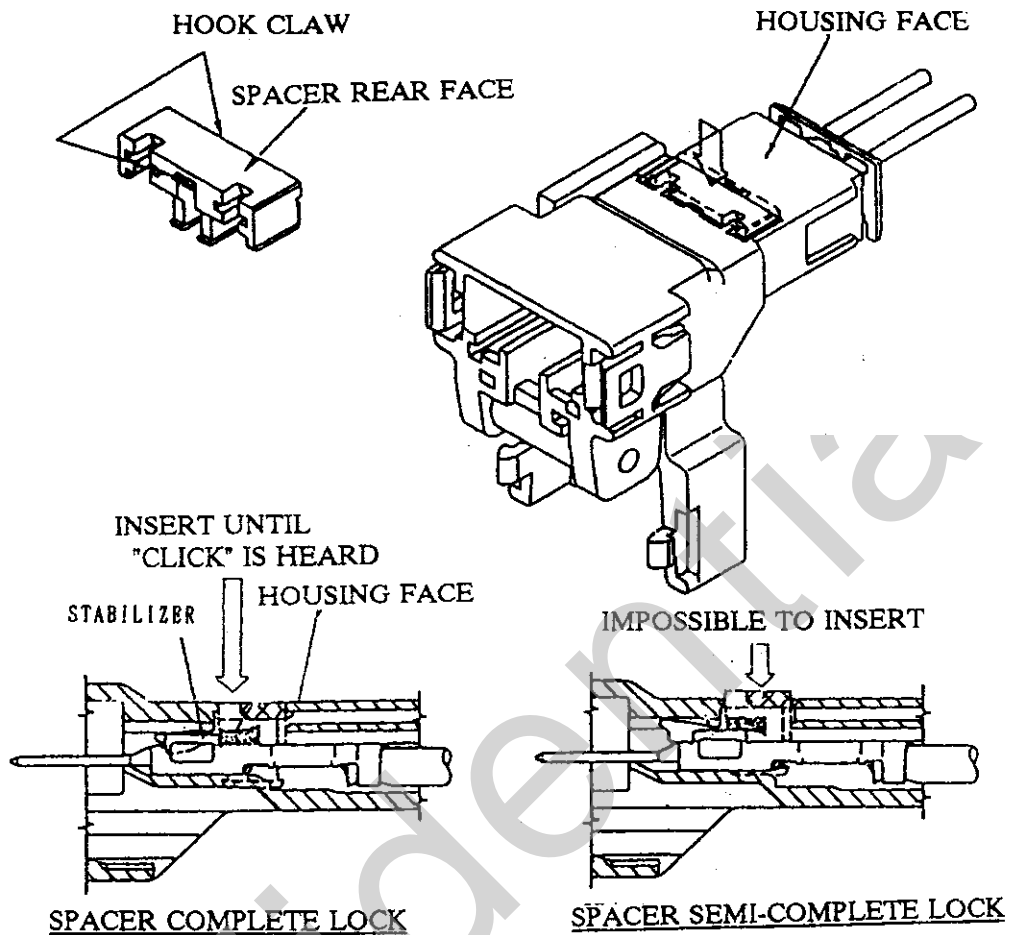

- 1) Spacer in semi-complete position to be completely inserted with a "click".

### Remarks:

- Both spacer hook claws are to be locked.
- When properly locked, spacer rear face is to be below housing face.
- If spacer insertion is hard or not possible, make sure that terminal is completely and correctly inserted (see above picture).

### 8-3 Boot Insertion (male/female in common)

This is inserted to prevent dirt and dust or wire vibration

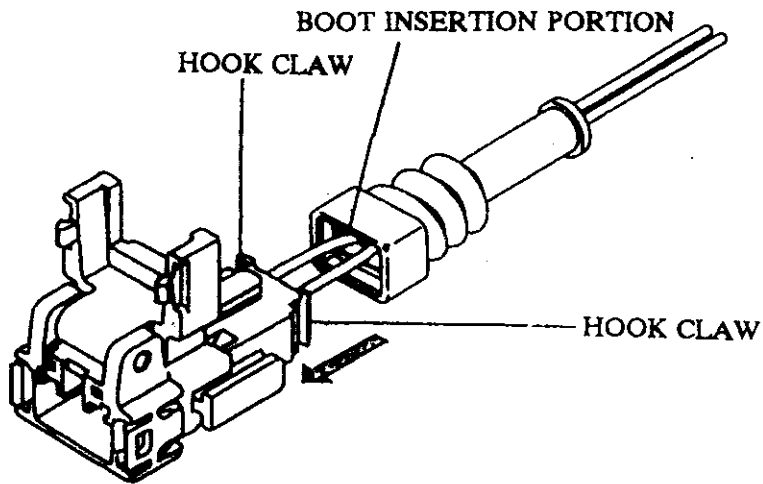

- 1) Pass boot through wire before terminal insertion.
- 2) Put boot insertion portion over boot hook claw.
- 3) Pull boot slightly in vertical and horizontal direction, making sure that boot is correctly inserted.

#### **PRECAUTION**

- Make sure that boot hook is not damaged.

#### 8-4 Set-up Method of Dust-Proof Cover

Dust-proof cover is put on to prevent dirt and dust from coming in, and will be removed before connector mating.

##### 1) Male Cover

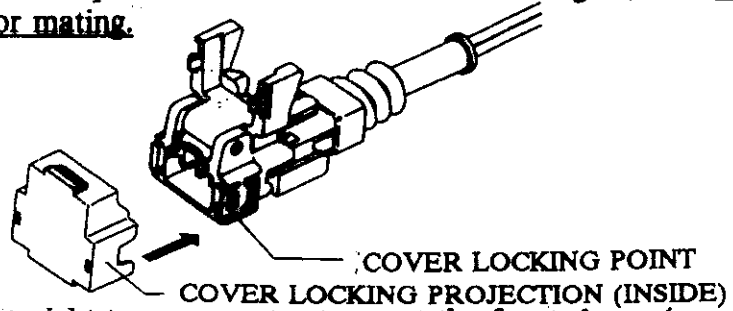

1. Put the cover on straight to a connector to meet the front shape (see above illustration).
2. To complete covering, insert it until "click" sound is heard.
3. Pull the cover lightly to ensure it is locked.

#### PRECAUTION

- Make sure both sides are locked.

##### 2) Female Cover

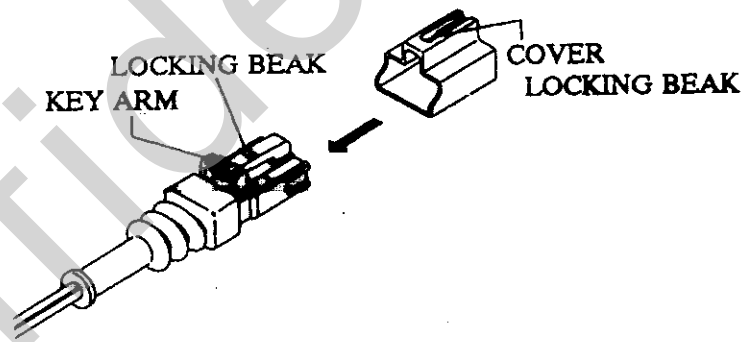

1. Put the cover on straight to a connector to meet the front shape (see above illustration).
2. To complete covering, insert it until "click" sound is heard.
3. Pull the cover lightly to ensure it is locked.

#### PRECAUTION

- Do not push key arm and put on cover at the same time.

## 9. REMOVAL OF TERMINAL, SPACER, AND DUST-PROOF COVER

If a terminal is to be removed because of mis-insertion, do so with care as described below. Only the well-trained and qualified should do this work. Use the designated tools for removal.

### 9-1 Tools

Terminal and Spacer Removal Operation (male and female in common)

TOOL

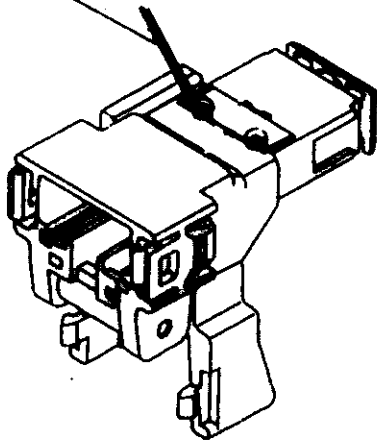

1. To begin: move spacer, then raise to primary locking position.

Put a tool in gap between housing and spacer (O mark) and push the spacer up, using leverage.

SPACER

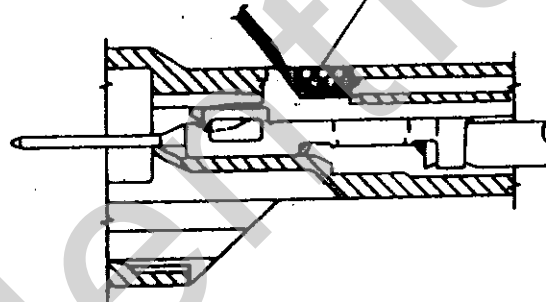

#### PRECAUTION

- Do not push a spacer too much, as it may break lock.

2. Insert tip of tool into the gap between terminal and elastic arm.

ELASTIC ARM

SPACER IS PRIMARY  
LOCKING POSITION

TOOL

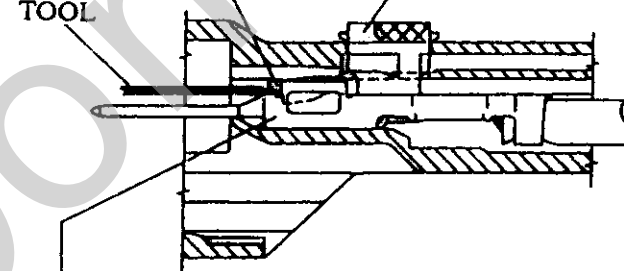

TERMINAL

3. Bend elastic arm with tool as illustrated below. Remove beak from hook of terminal, then pull wire and take the terminal off.

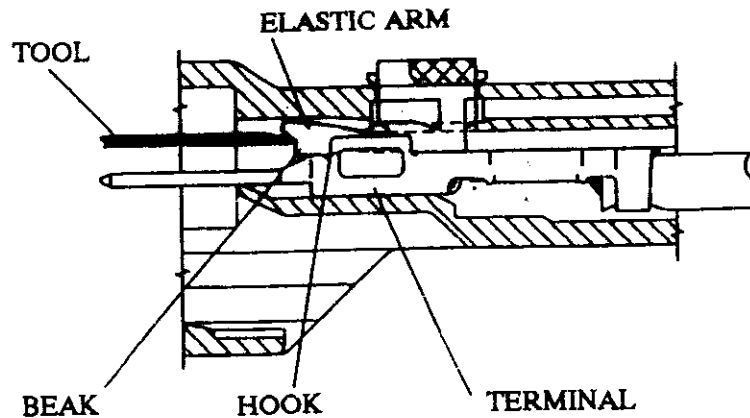

**PRECAUTION**

- Before performing this procedure, make sure that the point of tool is between the terminal and elastic arm.
- Use care to avoid damage to other parts when pushing elastic arm downwards.
- When pulling out female terminal, do not insert tool into terminal spring area. If tool is mis-inserted, replace terminal.

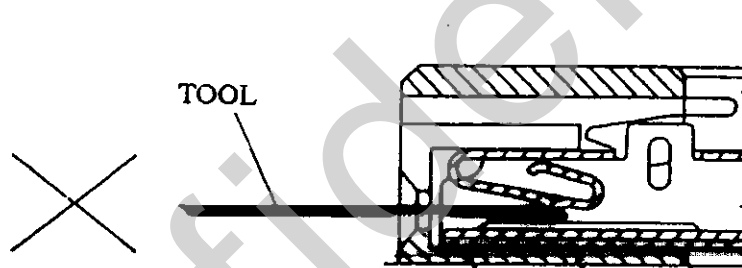

- If terminal removal is difficult, repeat the above procedure.
- After removing terminal, check both terminal and housing for deformities or scratches. Any parts in suspect condition are to be replaced with new ones.

### 9-3 Removal of Dust-Proof Cover

#### 1) Male Cover

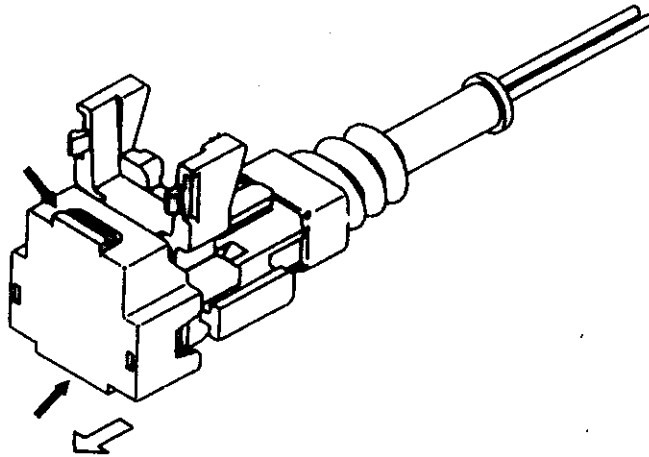

1. Hold black arrow part and connector, then pull it.

#### **PRECAUTION**

- Do not pull wires!

#### 1) Female Cover

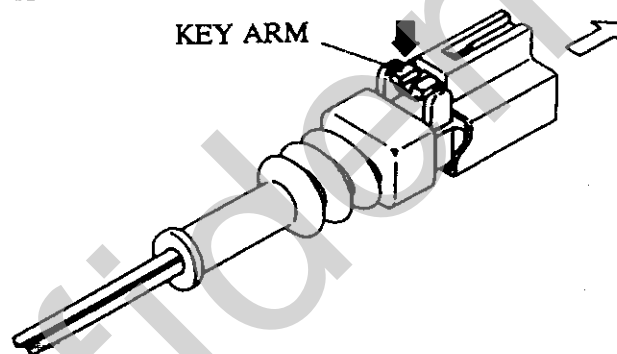

1. Hold dust-proof cover and connector; then remove it by pushing key arm.

#### **PRECAUTION**

- Do not pull wires!



## 10. W/H ASSEMBLY PRECAUTIONS

### 10-1 Primary Assembly Precautions

- 1) Take care that terminal does not get caught on anything.
- 2) Do not trail terminal along on the ground, which may cause it to get dirty or damaged in some way.
- 3) When assembling terminal to housing, do not squeeze wires to straighten them.

### 10-2 Tape Application Precautions

- 1) When rolling up wires with tape, wire should not be stretched; tensile force will concentrate on that wire and effect its quality. Make sure that tensile force is applied uniformly.

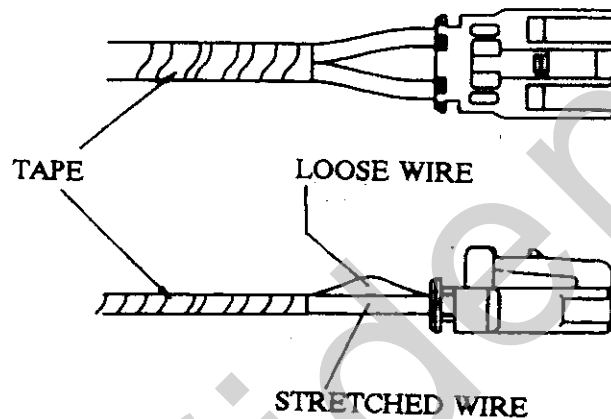

### 10-3 Circuit Check Precautions

- 1) Prepare a guide with high accuracy for tool to be used in distribution check or circuit check in order to prevent connector from wrenching.
- 2) If tool is mated to female connector at circuit check, control accuracy of tool in the same manner as when checking male connector.
- 3) If damage or deformity is found on terminal or housing, replace it with a new one.
- 4) Confirm that short spring and terminal of male terminal are in contact by circuit check.

## 11. METHODS OF MATING AND REMOVING DUAL LOCK CONNECTOR

### 11-1 Connection to Connector

- 1) Remove dust-proof cover.
- 2) Make sure that the connector is inserted correctly.
- 3) Connector should be connected with a "click".
- 4) Pull connector slightly and make sure locking arm is completely locked on.
- 5) Dual lock is to be located to the connection face and locked on the male connector.

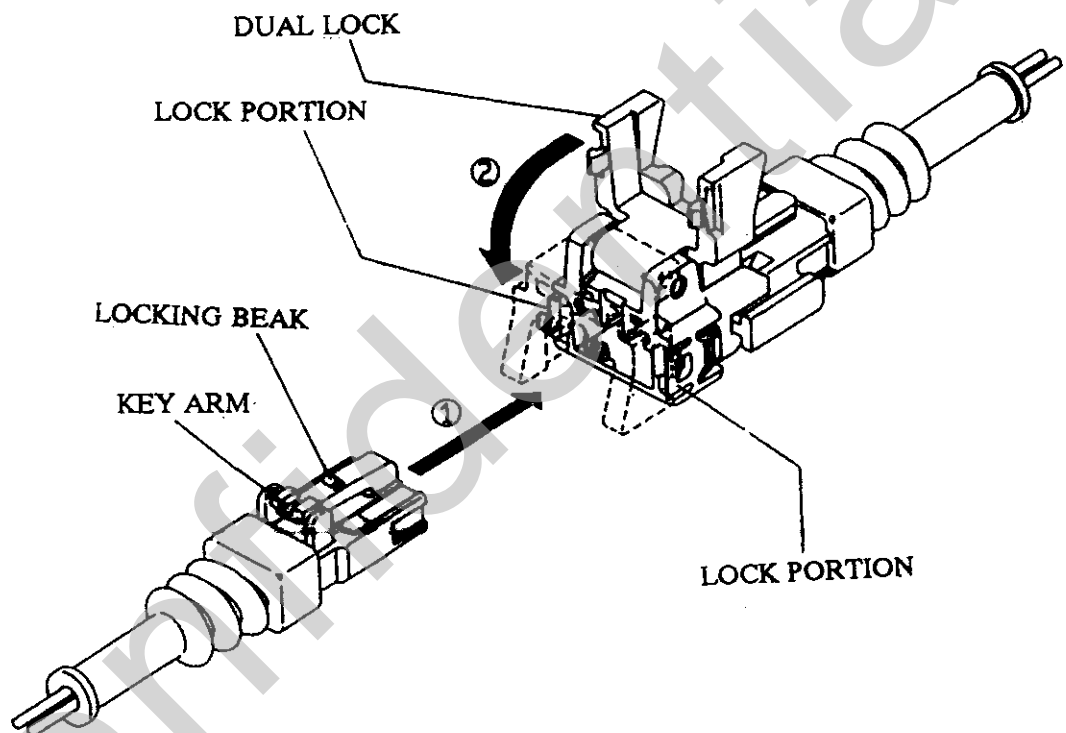

#### PRECAUTION

- Connector is to be connected by pressing key arm.
- If locking does not occur, make sure that connector is correctly connected.
- Make sure that both locks are secure.

## 11-2 Connector Removal

- 1) Release lock, pressing release portion.
- 2) Remove connector, pressing key arm and hold male/female connector.

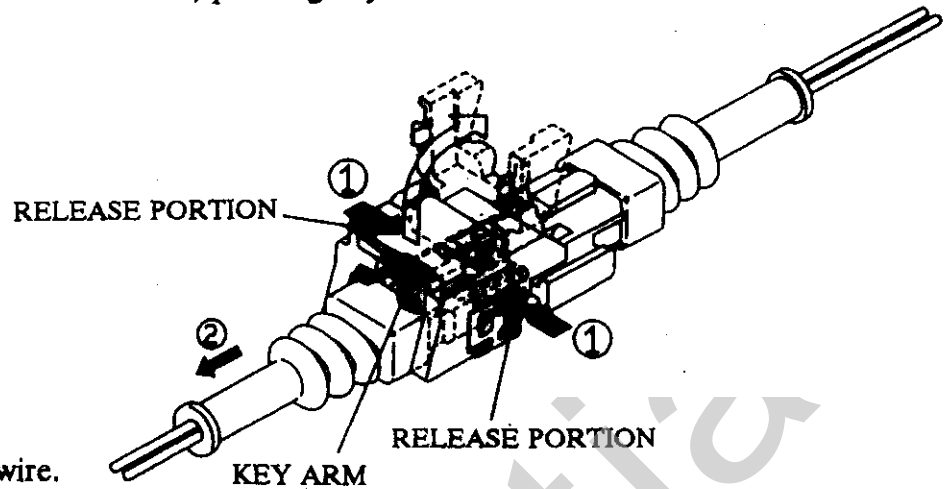

### REMARKS:

- Never pull wire.
- When lock is released, make sure that lock returns to upper front position.
- Make sure lock, hinge, and lock portion are not damaged.

## 2 POLE CONNECTOR FOR SQUIB (Reference)

1 Semi-Lock Position  
(Double Lock is Upper Front-  
Position)

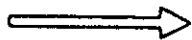

2 Lock Position  
(Ready for  
Double Locking)

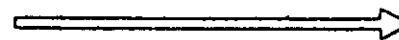

3 Double Lock Position  
(Double Lock Completed)

