

注記

1. かん合相手スライダー品番 : 7173-1471-30

NOTES

1. MATING SLIDER PART No. : 7173-1471-30

TABLE

ASSEMBLY PART NO. AND CH. CODE	NO.	PART NO. AND CH. CODE	MATERIAL	COLOR	QTY.
7325-4222	①	7125-4222	LCP-6	NATURAL	1
	②	7125-1578-08	PHOSPER BRONZE FOR SPRING GOLD PLATING	-	40
	③	7173-1466-08	BRASS TIN PLATING	-	2

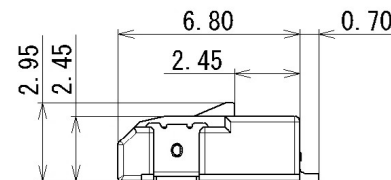
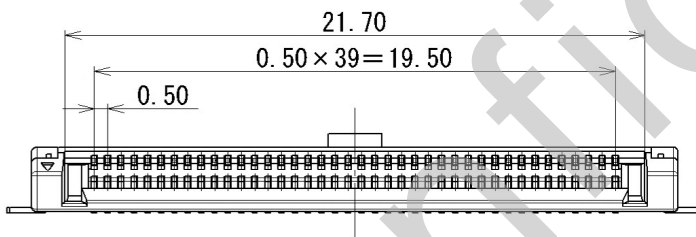
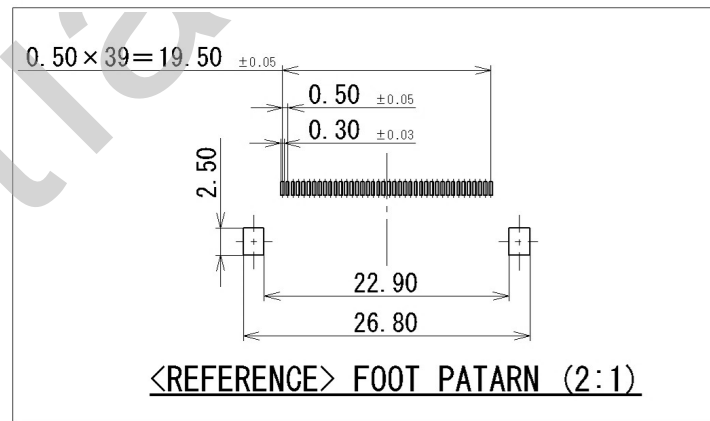
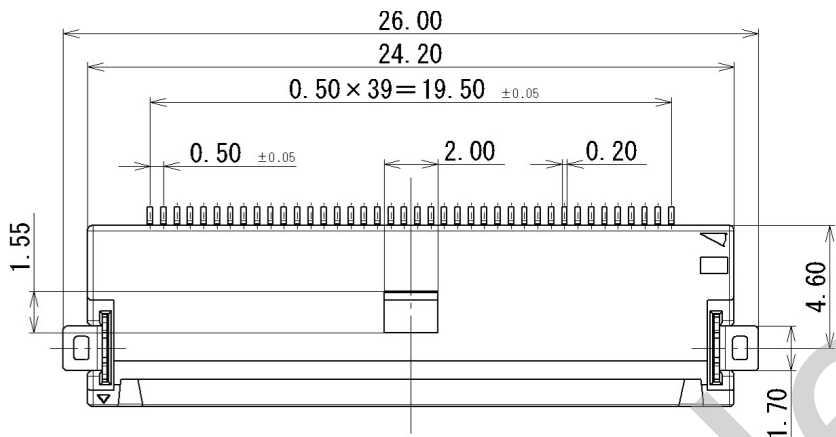

ISSUE MARK

				CUSTOMER				MATL. SPEC.				SEE TABLE		TREAT. & FIN.			
				CUSTOMER PART NO.				CUSTOMER DWG NO.				NAME		YFC05 II (40)			
2010/03/16				NEW				C10-124				K. O		OFFICE			
LET				DATE				REVISION RECORD				NO.		TRIAL PART NO.			
				GENERAL TOLERANCE				VENDOR				VENDOR NO.					
		IOMAX		50MAX		IOMAX		250MAX		2500VR		ANGLE		ECCENT			
A		±0.15		±0.2		±0.3		±0.5		±0.75		±30'		0.1			
B		±0.2		±0.3		±0.55		±0.95		±1.4		±30'		0.1			
C		±0.3		±0.5		±0.8		±1.4		±2		±30'		0.15			
SPECIFIED				MASS				DWG TYPE				R		NEW			
				g				APPROVED		CHECKED		CHECKED		DESIGN		DRAWN	
								T. OSHIMA		K. JINNO				K. OHYAMA		K. OHYAMA	
								2010/03/16		2010/03/16				2010/03/16		2010/03/16	
								DWG DATE				2010/03/16		UNIT		mm	
								SCL				5:1		ANGLE		3	
								PART NO. CH. CODE				7325-4222					
								DWG NO.				7325-4222:R					
								SET DWG NO.									
YAZAKI CORPORATION																	