

GENERAL TOLERANCE											
	10 MAX	50 MAX	100 MAX	250 MAX	250 OVR	R5 MAX	R10 MAX	R20 MAX	R20 OVR	ANGLE	ECCENT
A	±0.15	±0.2	±0.3	±0.5	±0.75					±3°	0.1
B	±0.2	±0.3	±0.55	±0.95	±1.4	±0.2	±0.3	±0.5	±2.5	±3°	0.1
C	±0.3	±0.5	±0.8	±1.4	±2					±3°	0.15

SUB ASSEMBLY PART NO. AND CH. CODE		NO.	YAZAKI PART NO. AND CH. CODE	PART NAME	MATERIAL	COLOR	QTY.
7288-3436		①	7188-3436	0.64 22P HOUSING MALE	PBT	NATURAL	1
		②	7172-0977	0.64 22P SPACER MALE	PBT	NATURAL	1
7288-3437-30		①	7188-3437-30	0.64 22P HOUSING MALE	PBT	BLACK	1
		②	7172-0977	0.64 22P SPACER MALE	PBT	NATURAL	1
7288-3438-40		①	7188-3438-40	0.64 22P HOUSING MALE	PBT	LIGHT GRAY	1
		②	7172-0977	0.64 22P SPACER MALE	PBT	NATURAL	1

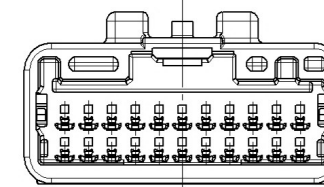
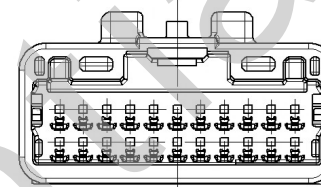
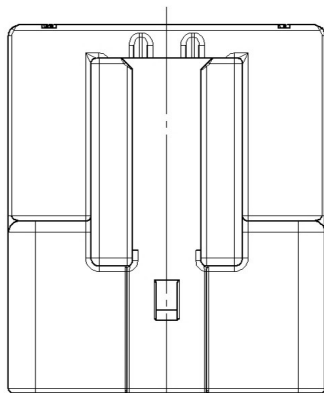

7288-3437-30

7288-3438-40

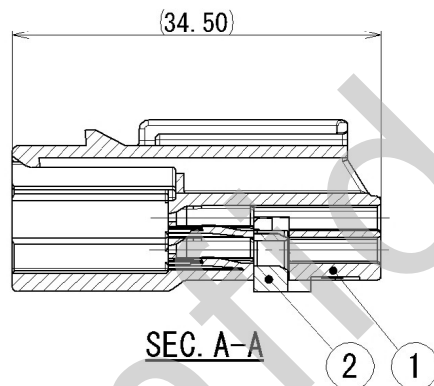
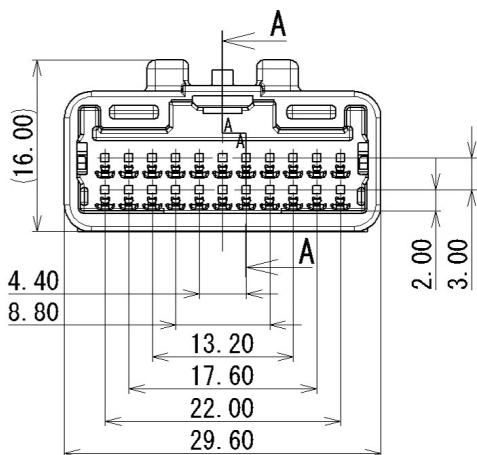

注記

1. かん合相手品番 : 7289-3439、7289-3440-30、7289-3441-40
2. 適用端子品番 : 7195-0157-02

NOTES

1. MATING PART NO. : 7289-3439, 7289-3440-30, 7289-3441-40
2. APPLICABLE TERMINAL NO. : 7195-0157-02

ISSUE MARK

				CUSTOMER				MATL. SPEC.				SEE TABLE		TREAT. & FIN.	
				CUSTOMER PART NO.				CUSTOMER DWG NO.				NAME			
2014/07/15				NEW				C14-Z416				0.64 22P HOUSING MALE			
LET				DATE				REVISION RECORD				SUB ASSEMBLY			
				NO.				J. L				OFFICE			
				CHKD				TRIAL PART NO.				X41386-PR69, X41386-PR75.			
				VENDOR				VENDOR NO.				X41386-PR81			
				GENERAL TOLERANCE				DWG TYPE				PART NO.			
				2014/07/15				R				7288-3436 ETC.			
				NEW				DWG SOURCE				CH. CODE			
				C14-Z416				NEW				7288-3436 ETC.			
				J. L				2014/07/15				DWG NO.			
				CHKD				2014/07/15				7288-3436:R			
				NO.				UNIT				SET DWG NO.			
				NEW				mm							
				2014/07/15				SCL				YAZAKI CORPORATION			
				2014/07/15				2:1							
				2014/07/15				ANGLE							
				±30'				3							
				0.1				APPROVED							
				0.1				S. CHIBA							
				±30'				Y. WADA							
				0.15				K. MATSUSHITA							
				MASS				K. MATSUSHITA							
				2014/07/15				J. LEGASPI							
				2014/07/15				2014/07/15							
				2014/07/15				2014/07/04							
				2014/07/15				2014/07/15							