

SUB ASS'Y PART NO. & C. C.	NO.	PART NO.	MATERIAL	COLOR	QTY.
7283-5590-40. \square	①	7183-5590-40	HPA	LIGHT GRAY	1
	②	7158-4210	HPA	NATURAL	1

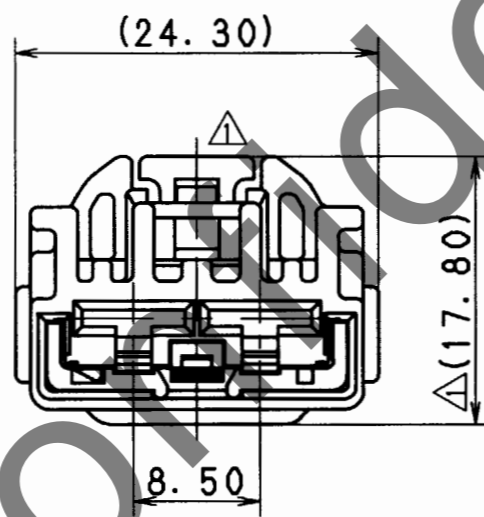
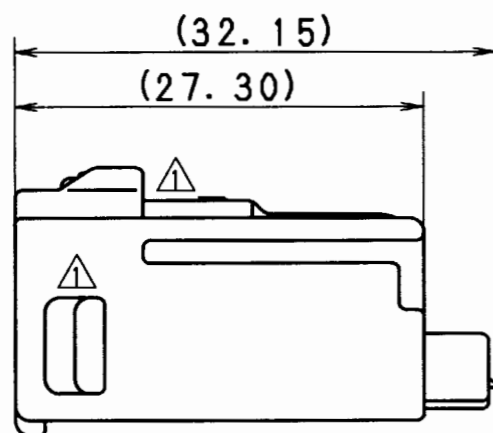
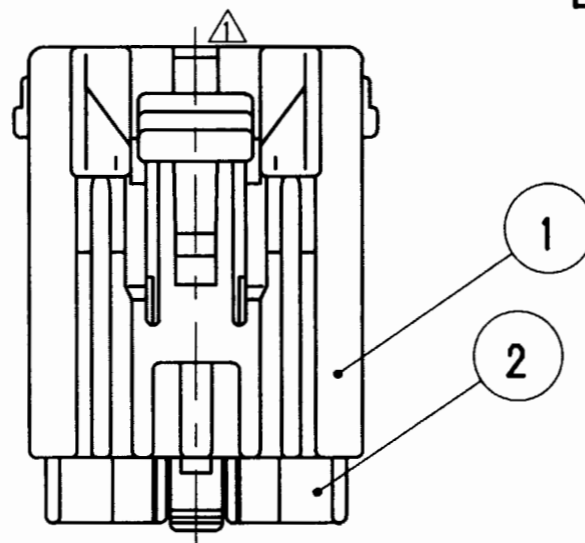

注記

- 1. 適用端子品番 : 7116-4120-02 ETC.
- 2. 嵌合相手品番 : 7282-5590-40

NOTES

- 1. APPLICABLE TERMINAL PART NO. : 7116-4120-02 ETC.
- 2. MATING PART NO. : 7282-5590-40

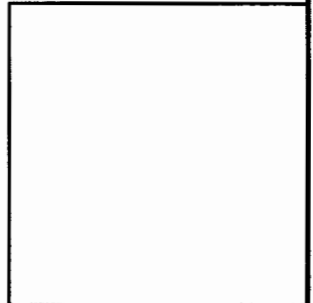

ISSUE MARK

				CUSTOMER				MATL. SPEC. SEE TABLE				TREAT. & FIN.			
				CUSTOMER PART NO.				CUSTOMER DWG NO.							
\triangle	97.03.24	CHANGED FORM. \square		C97-L504	H. K						NAME 6.3 SYSTEM CONNECTOR				
	95.08.28	NEW		C95-M157	I. I						2P (F) SUB ASS'Y				
LET	DATE	REVISION RECORD		NO.	CHKD		VENDOR				PART NO. 7283-5590-40. \square				
GENERAL TOLERANCE								VENDOR NO.				CH. CODE			
	10MAX	50MAX	100MAX	250MAX	250QVR	ANGLE	ECCENT	DWG TYPE	DWG SOURCE	DWG DATE	UNIT	SCL	ANGLE	DWG NO. 7283-5590-40:R	
A	± 0.15	± 0.2	± 0.3	± 0.5	± 0.75	$\pm 30'$	0.1	R	NEW	95.08.28	mm	2/1	3	SET DWG NO.	
B	± 0.2	± 0.3	± 0.55	± 0.95	± 1.4	$\pm 30'$	0.1	APPROVED	CHECKED	CHECKED	DESIGN	DRAWN		YAZAKI CORPORATION	
©	± 0.3	± 0.5	± 0.8	± 1.4	± 2	$\pm 30'$	0.15	SAWAYANAGI		SATOH					
SPECIFIED						MASS		g		197.03.28		97.03.27		97.03.27	
										95.06.13		97.03.24			