

SUB ASS'Y NO. & C. C	NO.	PART NO.	MATERIAL	COLOR	QTY.
7283-5563-40, B	①	7183-5563-40	HPA	LIGHT GRAY	1
	②	△ 7158-4186-50	HPA	△ ORANGE	1

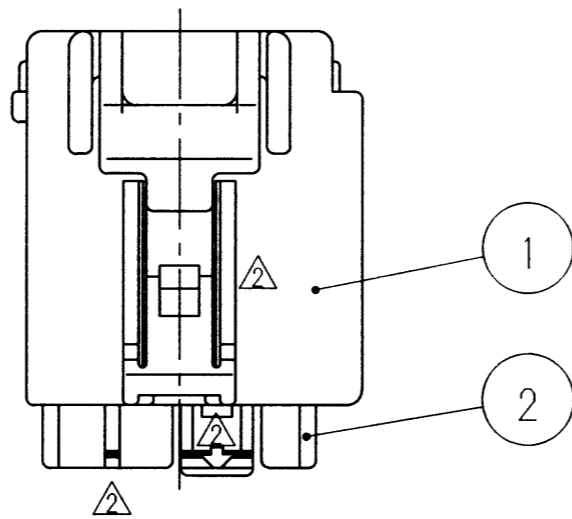

注記

- 1. 適用端子品番： 7116-4110-02 ETC.
- 2. 嵌合相手品番： 7282-5563-40

NOTES

- 1. APPLICABLE TERMINAL PART NO. : 7116-4110-02 ETC.
- 2. MATING PART NO. : 7282-5563-40

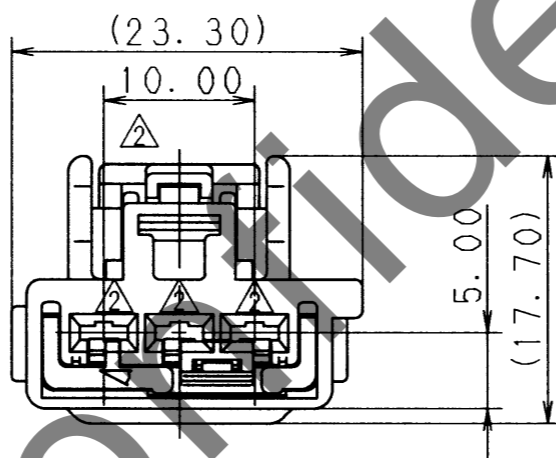
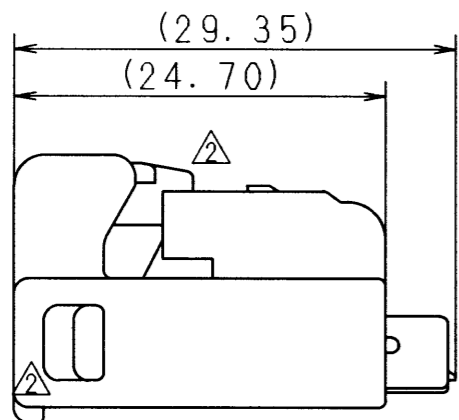

ISSUE MARK

△ 97.04.07		CHANGED FORM. B	C97-L646	H. K	CUSTOMER		MATL. SPEC.		SEE TABLE	TREAT. & FIN.				
△ 97.02.17		CHANGED PART NO. A	C97-L393	H. K	CUSTOMER PART NO.		CUSTOMER DWG NO.		NAME					
95.10.17		NEW	C95-M683	Y. Y	OFFICE		TRIAL PART NO.		2.8 SYSTEM CONNECTOR					
LET	DATE	REVISION RECORD	NO.	CHKD	VENDOR		VENDOR NO.		3P (F) SUB ASS'Y					
GENERAL TOLERANCE							DWG TYPE	DWG SOURCE	DWG DATE	UNIT	SCL	ANGLE		
A	±0.15	±0.2	±0.3	±0.5	±0.75	±30'	0.1	R	NEW	95.10.17	mm	2/1	3	
B	±0.2	±0.3	±0.55	±0.95	±1.4	±30'	0.1	APPROVED	CHECKED	CHECKED	DESIGN	DRAWN	PART NO.	
③	±0.3	±0.5	±0.8	±1.4	±2	±30'	0.15	蓮藤	植	花崎	HANAZAKI	TAKEUCHI	7283-5563-40, B	
SPECIFIED							MASS	97.04.14		97.04.14	97.04.10	95.10.05	97.04.07	CH. CODE
							9	197.04.14		97.04.14	97.04.10	95.10.05	97.04.07	DWG NO.
														7283-5563-40:R
														SET DWG NO.
														YAZAKI CORPORATION