

1

2

3

TABLE 1

SUB ASSEMBLY PART NO. AND CH. CODE	NO.	PART NO. AND CH. CODE	MATERIAL	COLOR	QTY.
△ 7283-1020 ETC.	①	SEE TABLE 2	△ SEE TABLE 2	SEE TABLE 2	1
	②	7157-4092 △ (7B57-4092)	△ HPA	△ NATURAL	1

TABLE 2

SUB ASSEMBLY PART NO. AND CH. CODE	PART NO. AND CH. CODE	△ MATERIAL	COLOR
7283-1020, △ △ (7C83-1020, △)	7183-1020 △ (7B83-1020)	△ HPA	NATURAL
7283-1020-10, △	△ 7183-1020-10	△ HPA	DARK GRAY
7283-1020-30, △	△ 7183-1020-30	△ HPA	BLACK
7283-1020-40, △	△ 7183-1020-40	△ HPA	LIGHT GRAY
7283-1020-50, △	△ 7183-1020-50	△ HPA	ORANGE
7283-1020-60, △	△ 7183-1020-60	△ HPA	GREEN
7283-1020-70, △ △ (7C83-1020-70, △)	△ 7183-1020-70 △ (7B83-1020-70)	△ HPA	YELLOW
7283-1020-80, △	△ 7183-1020-80	△ HPA	BROWN
7283-1020-90, △	△ 7183-1020-90	△ HPA	BLUE

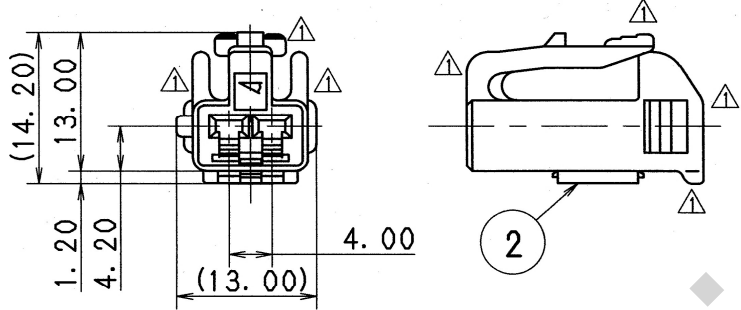
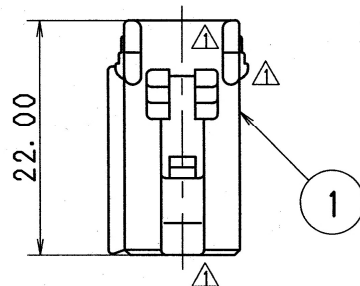

NOTES

- △ 1. MATING PART NO. : 7282-1020 ETC. (7C82-1020 ETC.)
- 2. APPLICABLE TERMINAL NO. : 7116-4020 ETC.
- △ 3. PART NUMBERS IN PARENTHESIS SHALL BE USED FOR AIR BAG (A/B) CIRCUITS AND OTHER CIRCUITS DESIGNATED FOR SPECIAL MONITOR.

注記

- △ 1. 嵌合相手品番 : 7282-1020 ETC. (7C82-1020 ETC.)
- 2. 適用端子品番 : 7116-4020 ETC.
- △ 3. () 内品番はA/B回路及び特別管理回路に使用すること。

△	05/03/24	CHANGED MATERIAL, ETC.	C05-Z525	N. T
△	99/02/03	CHANGED NOTE	C99-L178	T. M
△	96/12/02	ADDED A/B PART NO.	C96-N180	H. K
△	95/03/20	CHANGED MATERIAL, △	C95-L362	M. K
△	93/10/30	CHANGED MATERIAL & ADDED COLOR NO.	C93-P174	C. M
△	90/11/10	CHANGED SPACER COLOR.	C90-M203	M. H
△	90/05/11	ADDED PART NO.	C90-L481	H. Y
△	90/03/28	CHANGED FORM & SPACER PART NO. & RENEW	C90-L338	K. O
△	88/12/24	NEW	C89-L005	K. J
LET	DATE	REVISION RECORD	NO.	CHKD

CUSTOMER		MATL. SPEC.	SEE TABLE 1	TREAT. & FIN.
CUSTOMER PART NO.		CUSTOMER DWG NO.		
OFFICE		TRIAL PART NO.		
VENDOR		VENDOR NO.		

NAME △ 2. 3 II (090 II) 2P CONNECTOR	
SUB ASSEMBLY FEMALE	

GENERAL TOLERANCE					
	10MAX	50MAX	100MAX	250MAX	2500VR
A	±0.15	±0.2	±0.3	±0.5	±0.75
B	±0.2	±0.3	±0.55	±0.95	±1.4
◎	±0.3	±0.5	±0.8	±1.4	±2
SPECIFIED					MASS
					g

DWG TYPE	DWG SOURCE	DWG DATE	UNIT	SCL	ANGLE
R	NEW	89/01/13	mm	2:1	3
APPROVED	CHECKED	CHECKED	DESIGN	DRAWN	
Y. OHTA	Y. OHTA	D. GABRIEL	ROMEL GALVA		
'05.03.24	'05.03.24	'05.03.24	88/04/15	05/03/24	

PART NO. 7283-1020 ETC. (7C83-1020 ETC.) △	CH. CODE
DWG NO. 7283-1020:R	SET DWG NO.
YAZAKI CORPORATION	

1

2

3

