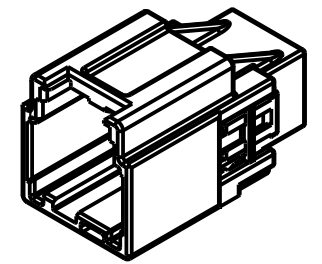
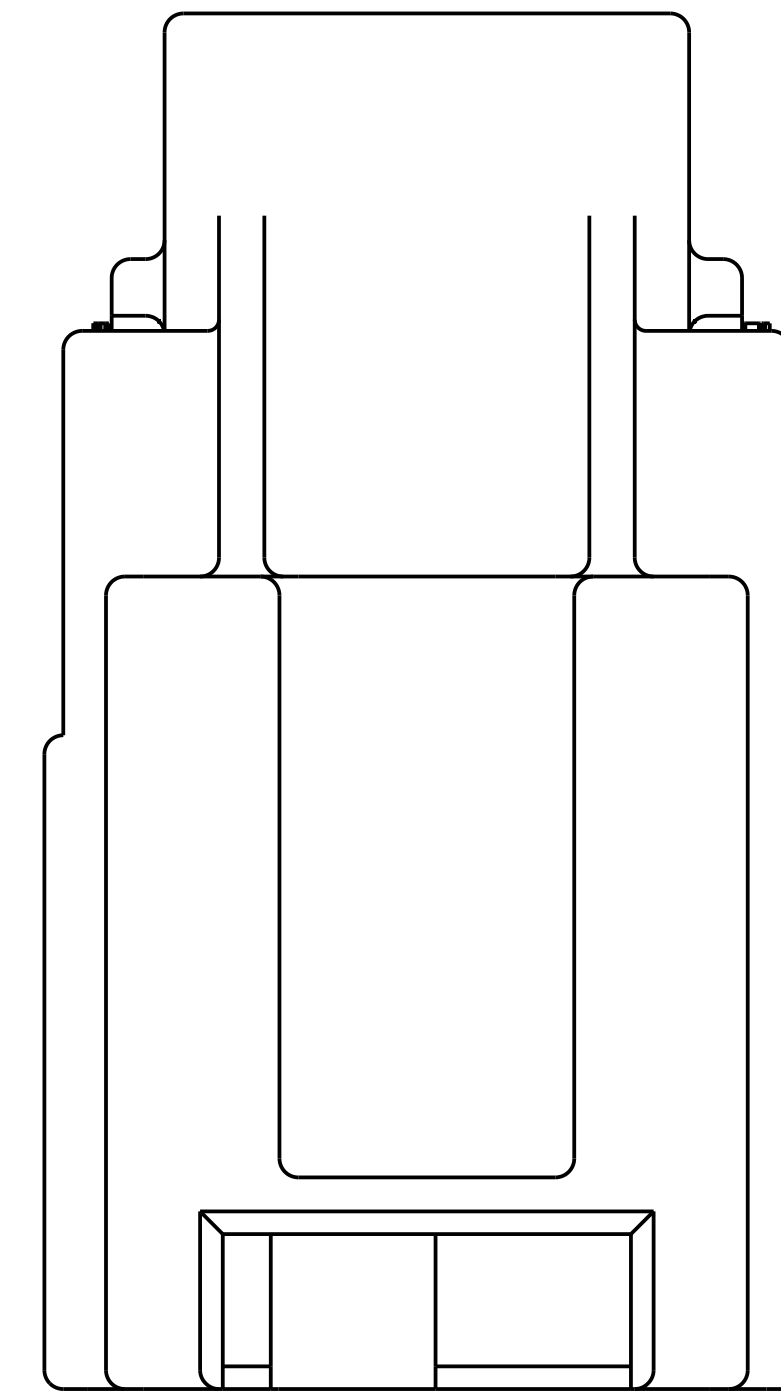
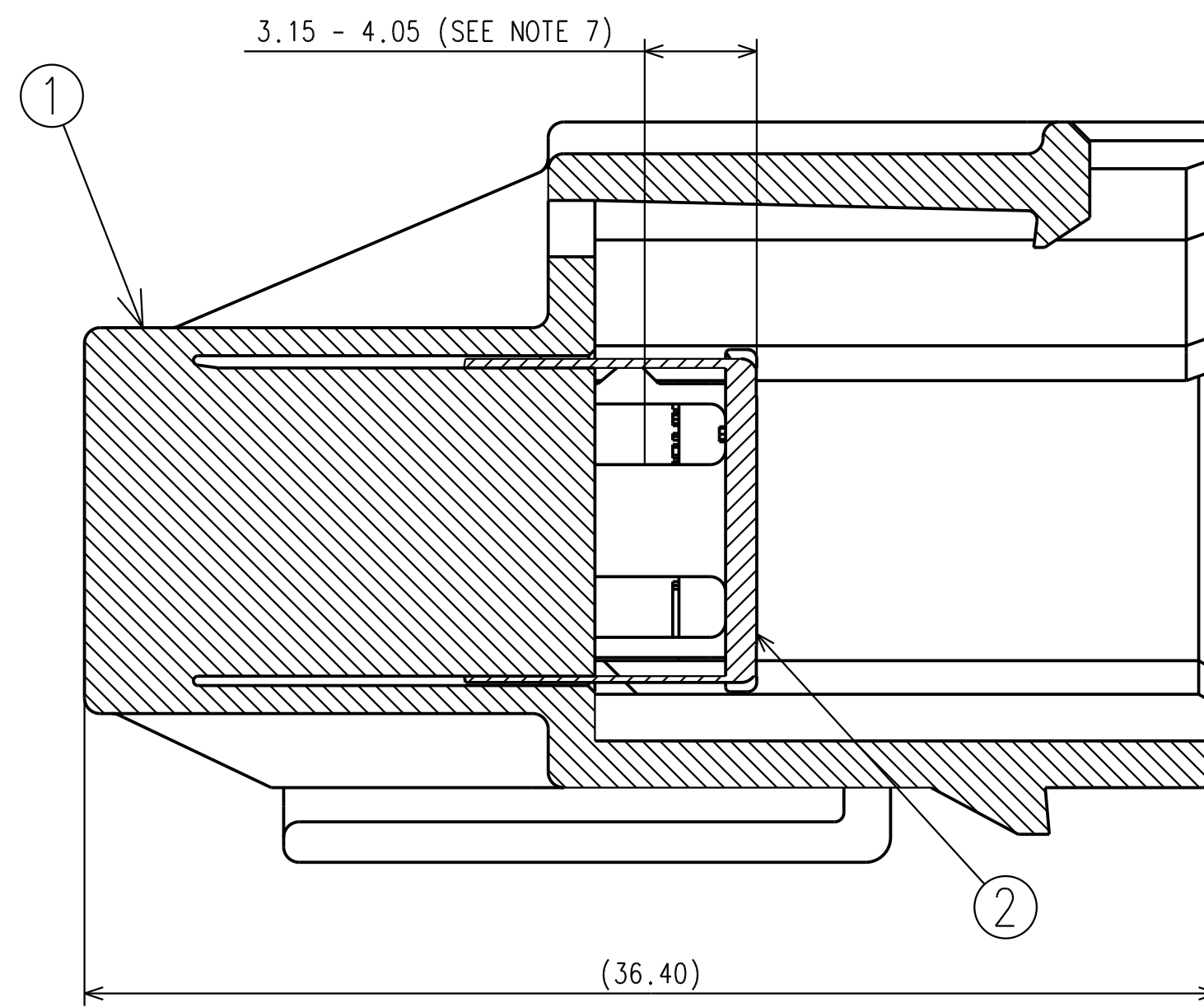
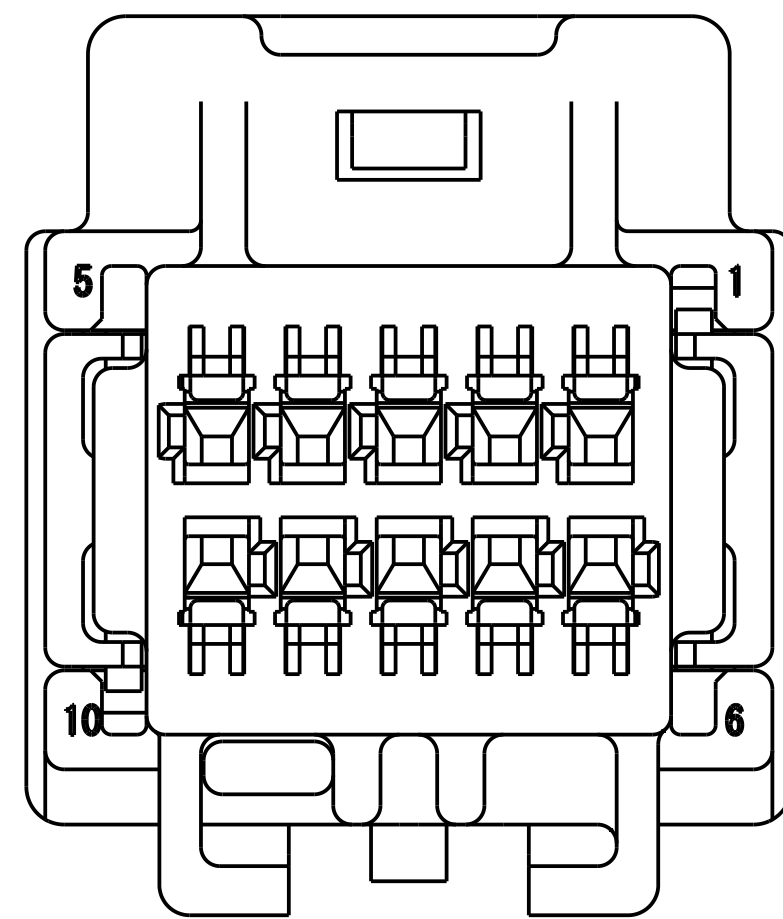

TABLE 1	SUB ASSEMBLY PART NUMBER	NO.	PART NUMBER	PART NAME	MATERIAL	COLOR	QUANTITY
7282-9040-30 ETC.		①	7182-9034-30	10P 0.64 YESC KAIZEN UNSEALED MALE HOUSING	PBT+GF	BLACK	1
		②	7158-6945	10P 0.64 YESC KAIZEN UNSEALED MALE TPA	PBT+GF	NATURAL	1

- NOTES:
- PARTS MUST BE PURCHASED FROM YAZAKI.
 - PARTS MUST BE FREE OF FLASH AND IMPERFECTIONS THAT AFFECT FUNCTION.
 - APPLICABLE TERMINAL: SEE 7114-4618-02:R DRAWING. (0.64 YESC KAIZEN)
 - MATING PART NUMBER: SEE TABLE 2
 - PART SATISFIES USCAR-2, REV. 3 DATED 4/2001, CLASS 2 WITH THE FOLLOWING EXCEPTIONS:
 - SECTION 5.4.2 LOCK DEFLECTION FORCE 70N MAX.
 - PART TO COMPLY WITH YPES-31-038 REQUIREMENTS.
 - THIS DIMENSION SHOWS THE PRE-SET POSITION OF THE TPA.
 - THIS DRAWING IS TO BE USED FOR INTERNAL YAZAKI PSW SUBMISSION.



(1/1)



SECTION A-A

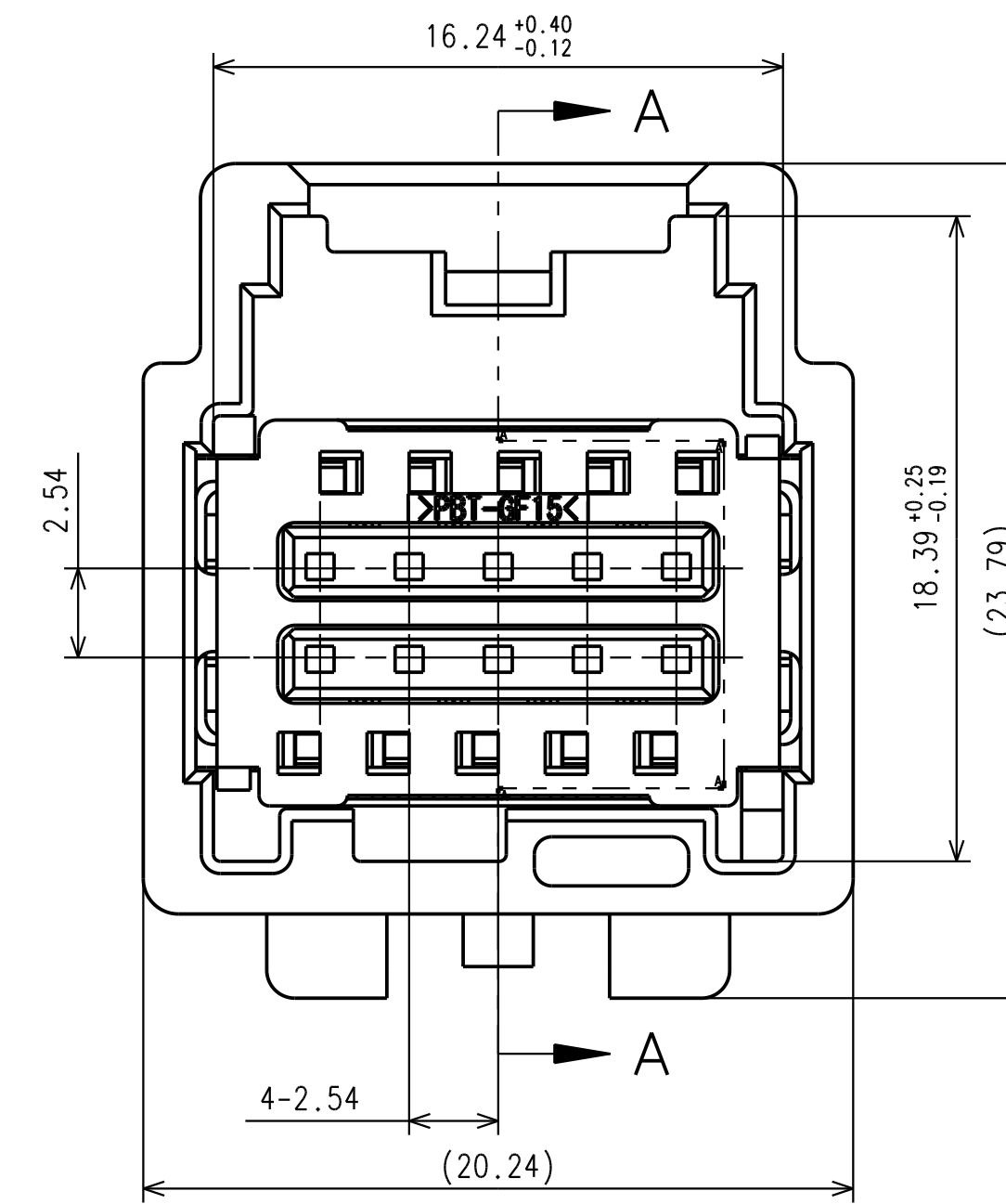

ISSUE MARK

CUSTOMER		MATERIAL SPEC: SEE TABLE 1		TREAT. & FIN: N/A	
CUSTOMER PART NO.		CUSTOMER DWG NO.		NAME 10P 0.64 YESC KAIZEN UNSEALED	
OFFICE YNA		TRIAL PART NO.		MALE SUB-ASSEMBLY	
VENDOR		VENDOR NO.		PART NO. 7282-9040-30	
VENDOR NO.		DWG SOURCE		DWG NO. 7282-9040-30:R	
DWG DATE		UNIT		SCL	
06-03-2014		mm		5/1	
APPROVED		CHECKED		DESIGN	
J. JACKSON		J. JACKSON		DRAWN	
GERWATOWSKI		MATHESON		10-05-2005	
06-03-2014		06-03-2014		YAZAKI CORPORATION	

GENERAL TOLERANCE								
	10MAX	50MAX	100MAX	250MAX	2500VR	ANGLE	ECCENT	
A	±0.15	±0.2	±0.3	±0.5	±0.75	±30'	0.1	
B	±0.2	±0.3	±0.55	±0.95	±1.4	±30'	0.1	
©	±0.3	±0.5	±0.8	±1.4	±2	±30'	0.15	
SPECIFIED							WEIGHT	g

LET	DATE	REVISION	RECORD	NO.	CHKD
-	06-03-2014	NEW		C14-A067	JM