

TABLE 1

SUB ASSEMBLY PART NO. AND CH. CODE	NO.	PART NO. AND CH. CODE	MATERIAL	COLOR	QTY.
7282-8922 ETC.	①	SEE TABLE 2	△ HPA	SEE TABLE 2	1
	②	7157-4091	△ HPA	NATURAL	1

TABLE 2

SUB ASSEMBLY PART NO. AND CH. CODE	PART NO. AND CH. CODE	COLOR
7282-8922.□	7182-8922	NATURAL
7282-8922-30.□	7182-8922-30	BLACK
7282-8922-40.□	7182-8922-40	GRAY
7282-8922-90.□	7182-8922-90	BLUE

△ 注記

- 適用端子番 : 7114-4020 (AVSS 0.3~AVS 0.5)
7114-4021 (AVS 0.5~AVS 1.25)
7114-4022 (AVSS 2)
- 嵌合相手番 : 7283-8922 ETC.

NOTES

- APPLICABLE TERMINAL NO. : 7114-4020 (AVSS 0.3~AVS 0.5)
7114-4021 (AVS 0.5~AVS 1.25)
7114-4022 (AVSS 2)
- MATING PART NO. : 7283-8922 ETC.

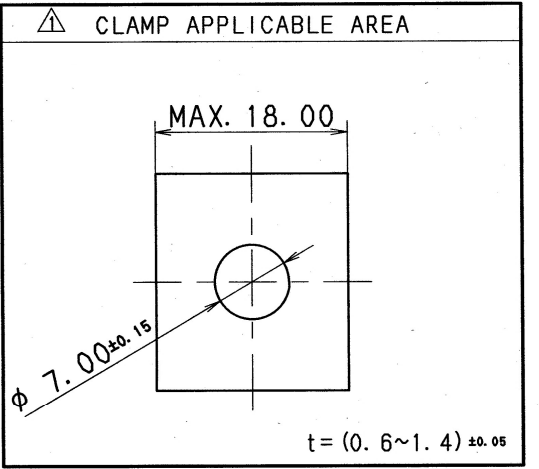

ISSUE MARK

				CUSTOMER				MATT. SPEC. SEE TABLE 1			TREAT. & FIN.	
				CUSTOMER PART NO.				CUSTOMER DWG NO.			NAME △ 2.3Ⅱ (090Ⅱ) 2P CONNECTOR	
△ 05/02/22 CHANGED MATERIAL ETC. □ C05-Z384 T. H				OFFICE				TRIAL PART NO.			SUB ASSEMBLY MALE	
93/01/09 NEW C93-L056 M. H				VENDOR				VENDOR NO.			PART NO. 7282-8922 ETC.	
LET DATE REVISION RECORD NO. CHKD				DWG TYPE				DWG SOURCE			DWG NO. △ 7282-8922 : R	
GENERAL TOLERANCE				APPROVED				DESIGN			DRAWN	
10MAX 50MAX 100MAX 250MAX 2500VR ANGLE ECCENT				R NEW 93/01/09 mm 2:1 3				TE. SUZUKI			A. PACABIS	
A ±0.15 ±0.2 ±0.3 ±0.5 ±0.75 ±30' 0.1				CHECKED				05.02.22			ROMEL GHUZA	
B ±0.2 ±0.3 ±0.55 ±0.95 ±1.4 ±30' 0.1				MASS				91/02/12			05/02/22	
C ±0.3 ±0.5 ±0.8 ±1.4 ±2 ±30' 0.15				g				05.02.22			05/02/22	
SPECIFIED											YAZAKI CORPORATION	