

1

2

3

YAZAKI SUB ASS'Y PART NO.	NO.	YAZAKI PART NO.	MATERIAL	COLOR	QTY.
7282-8631	①	7182-8631	PBT	NATURAL	1
	②	△7157-6770	PBT	△NATURAL	1
△7282-8631-30	①	7182-8631-30	PBT	BLACK	1
	②	△7157-6770	PBT	△NATURAL	1

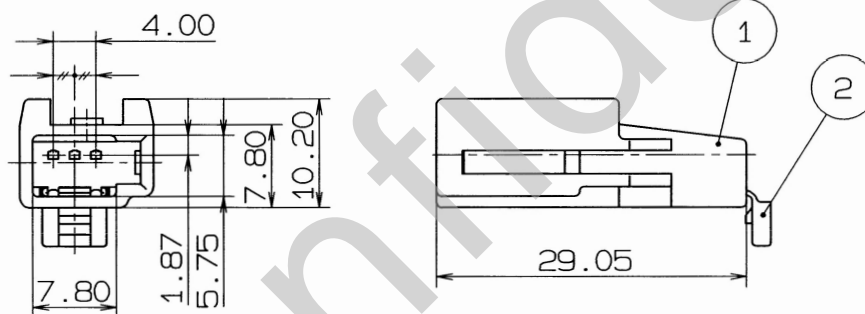
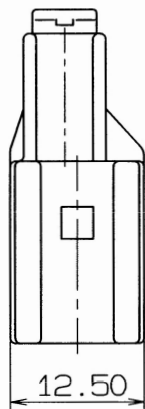

注記

1. 嵌合相手品番 : 7283-8630

△ : 7283-8630-30

△ 2. 使用ターミナル品番 : 7114-1670-02, 7114-1670-08
7114-1800-02

NOTES

1. MATING PART NO.: 7283-8630

△ : 7283-8630-30

△ 2. APPLICABLE TERMINAL NO.: 7114-1670-02
7114-1670-08
7114-1800-02

ISSUE MARK

LET	DATE	REVISION RECORD	NO.	CHKD	CUSTOMER	CUSTOMER PART NO.	CUSTOMER DWG NO.	MATL. SPEC.	TREAT. & FIN.
△	96.03.22	ADDED PART NO.	C96-L475	H.K	CUSTOMER			SEE TABLE 1	
△	94.11.18	CH.REAR HOLDER COLOR	C94-M537	O.S					
	93.06.21	NEW	C93-6755	T.Y					
GENERAL TOLERANCE					VENDOR			NAME	
					VENDOR NO.			A TYPE CONNECTOR 3P-P (M)	
								SUB ASS'Y	
	10MAX	50MAX	100MAX	250MAX	2500VR	ANGLE	ECCENT	PART NO.	△ 7282-8631 ETC.
A	±0.15	±0.2	±0.3	±0.5	±0.75	±30'	0.1	CH.CODE	
B	±0.2	±0.3	±0.55	±0.95	±1.4	±30'	0.1	DWG NO.	7282-8631: R
©	±0.3	±0.5	±0.8	±1.4	±2	±30'	0.15	YAZAKI CORPORATION	
SPECIFIED					MASS	g			
					96.03.26	96.3.26		93.06.21 96.03.22	

1

2

3