

2		3			
SUB ASS'Y PART NO. & C. C	NO.	PART NO.	MATERIAL	COLOR	QTY.
7282-5590-40. A	①	7182-5590-40	HPA	LIGHT GRAY	1
	②	7158-4212	HPA	NATURAL	1

注記

- 1. 通用端子番 : 7114-4120-02 ETC.
- 2. 嵌合相手番 : 7283-5590-40

NOTES

- 1. APPLICABLE TERMINAL PART NO. : 7114-4120-02 ETC.
- 2. MATING PART NO. : 7283-5590-40

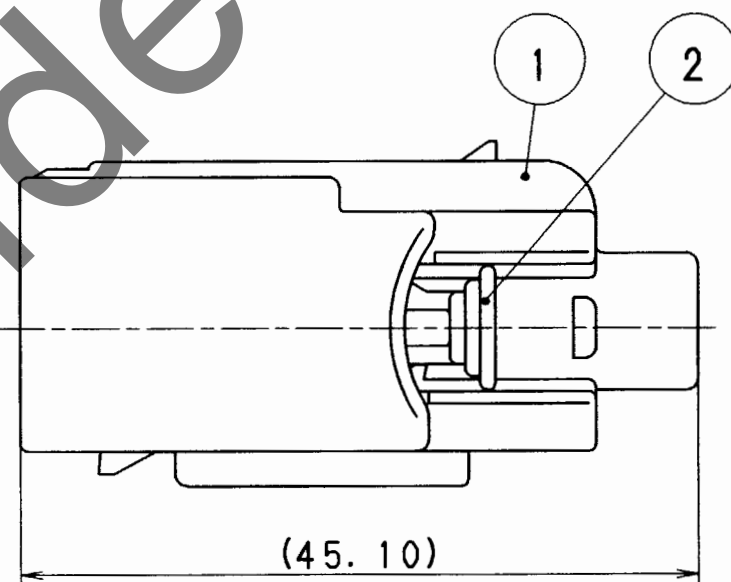

ISSUE MARK

		CUSTOMER				MATERIAL SPEC. SEE TABLE				TREAT. & FIN.						
		CUSTOMER PART NO.		CUSTOMER DWG NO.												
△	97.03.12	CHANGED FORM. A	C97-L500	H. K					NAME △ 6.3 SYSTEM CONNECTOR							
	95.08.28	NEW	C95-M157	I. I					2P (M) SUB ASS'Y							
LET	DATE	REVISION RECORD	NO.	CHKD	VENDOR				PART NO. 7282-5590-40. A							
GENERAL TOLERANCE					VENDOR NO.				CH. CODE 7282-5590-40:R							
	10MAX	50MAX	100MAX	250MAX	2500VR	ANGLE	ECCENT	DWG TYPE	DWG SOURCE	DWG DATE	UNIT	SCL	ANGLE	DWG NO. 7282-5590-40:R		SET DWG NO.
A	±0.15	±0.2	±0.3	±0.5	±0.75	±30'	0.1	R	NEW	95.08.28	mm	2/1	3			
B	±0.2	±0.3	±0.55	±0.95	±1.4	±30'	0.1	APPROVED	CHECKED	CHECKED	DESIGN	DRAWN				
©	±0.3	±0.5	±0.8	±1.4	±2	±30'	0.15	東藤	植	木村	SAWAYANAGI	AOYAMA				
SPECIFIED					MASS								YAZAKI CORPORATION			
					g											