

SUB ASSEMBLY PART NUMBER	NO.	PART NUMBER	PART NAME	MATERIAL	COLOR	QUANTITY
7282-3440-40	①	7182-3440-40	3P KAIZEN YESC 1.5mm UNSEALED MALE HOUSING	PBT + GF	LIGHT GRAY	1
	②	7158-6191	3P KAIZEN YESC 1.5mm UNSEALED MALE TPA	PBT	NATURAL	1

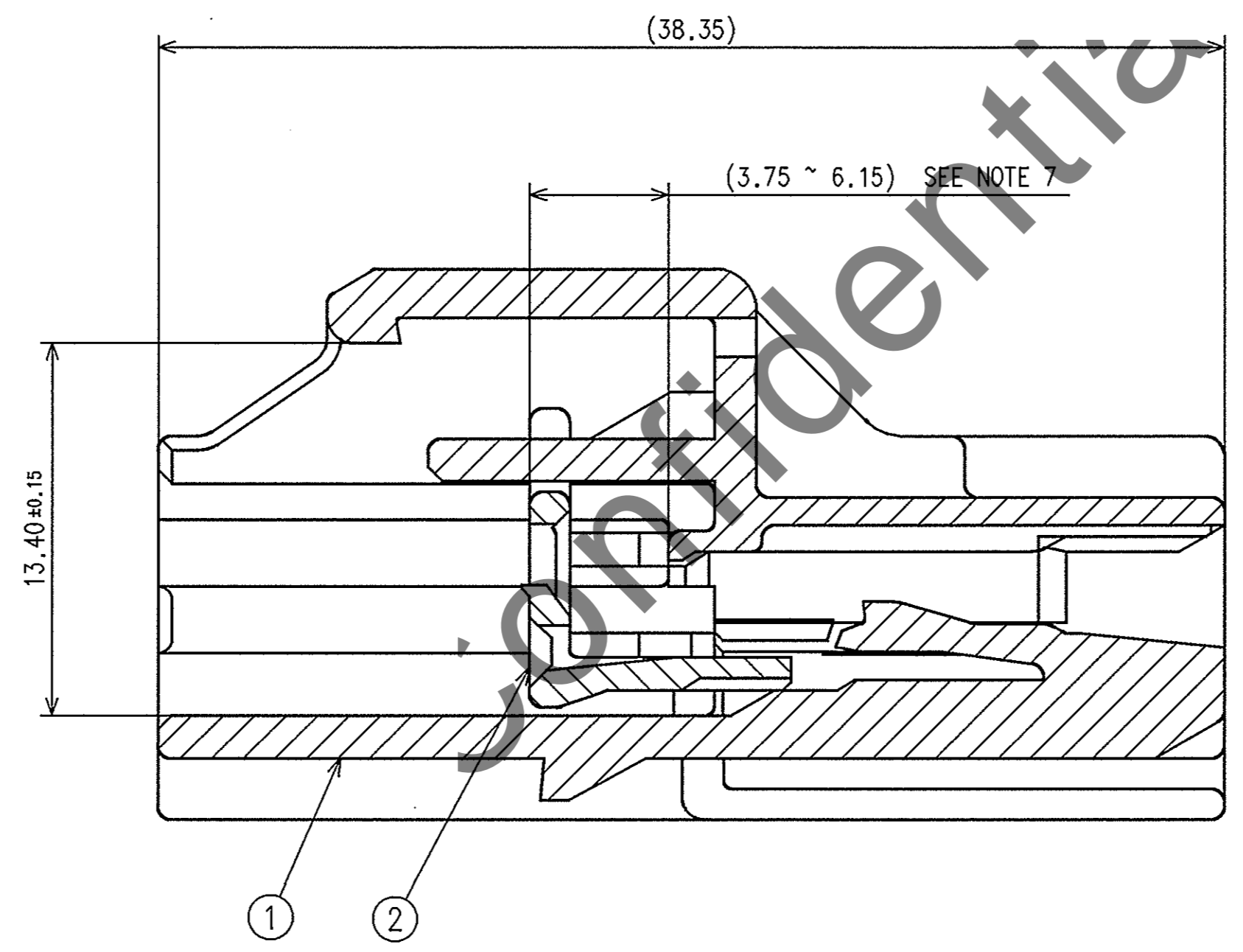

SECTION A-A

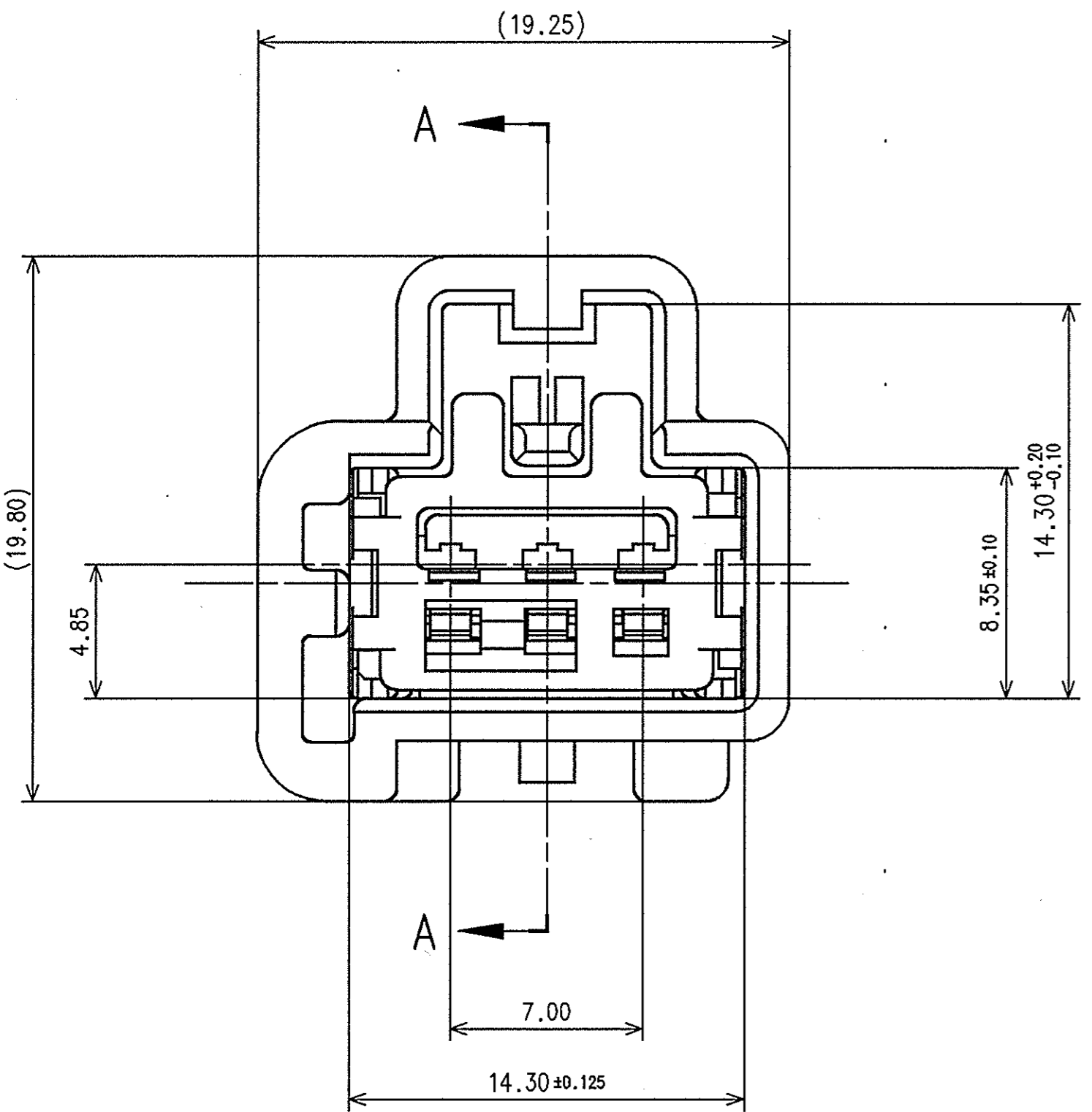
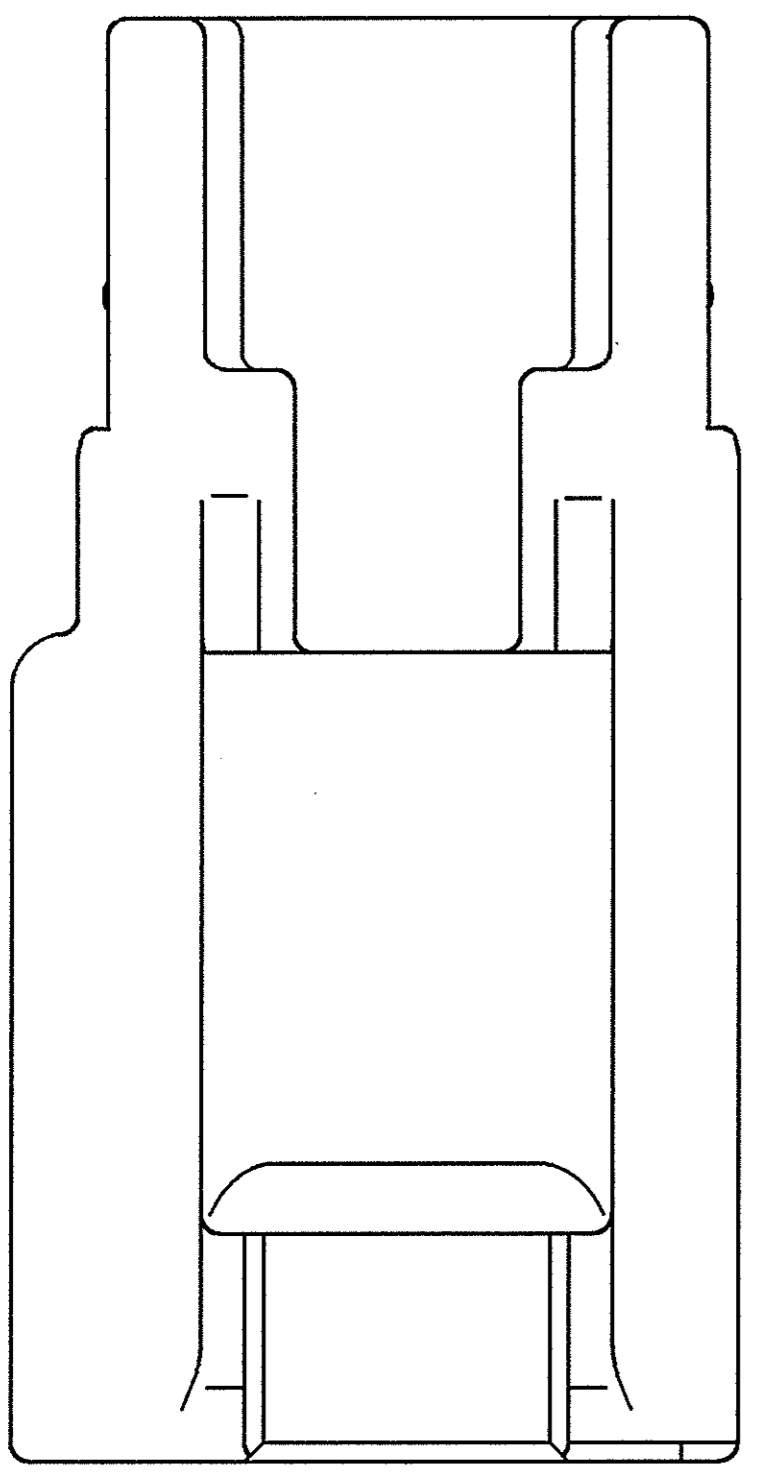
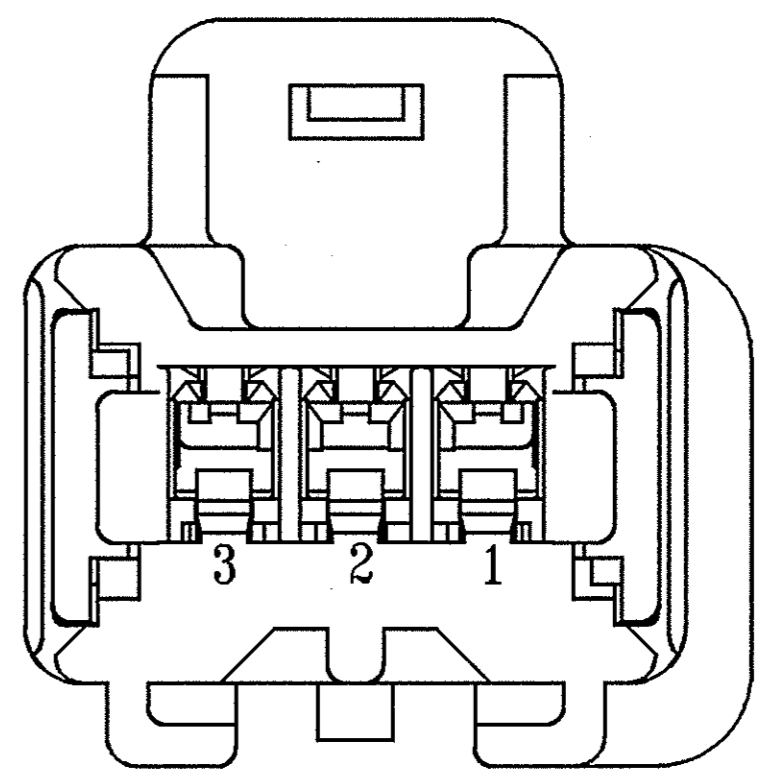

- NOTES:
- PARTS MUST BE PURCHASED FROM YAZAKI.
  - PARTS MUST BE FREE OF FLASH AND IMPERFECTIONS THAT AFFECT FUNCTION.
  - APPLICABLE TERMINAL: SEE 7114-4100-02:R DRAWING. (1.5mm)
  - MATING PART NUMBER: 7283-3440-40 OR EQUIVALENT
  - PART DESIGNED TO SATISFY USCAR-2, REVISION 3, APRIL 2001, CLASS 2.
  - PART TO COMPLY WITH YPES-31-038 REQUIREMENTS.
  - THIS DIMENSION SHOWS THE PRE-SET POSITION OF THE TPA.
  - THIS DRAWING IS TO BE USED FOR INTERNAL YAZAKI PSW SUBMISSION.

LET	DATE	REVISION RECORD	NO.	CHKD
-	09.22.09	NEW	C09-A679	MMR

GENERAL TOLERANCE		APPROVED		CHECKED		DESIGN		DRAWN		PART NO.				
A	±0.15	±0.2	±0.3	±0.5	±0.75	±30'	0.1	R	7282-3440-40:M	09.22.09	mm	5/1	3	7282-3440-40
B	±0.2	±0.3	±0.55	±0.95	±1.4	±30'	0.1	APPROVED	CHECKED	CHECKED	DESIGN	DRAWN		7282-3440-40:R
Ⓞ	±0.3	±0.5	±0.8	±1.4	±2	±30'	0.15				DESIGN	ONG		YAZAKI CORPORATION
SPECIFIED		WEIGHT		g		09.30.09		09.29.09		10.11.02		09.28.09		

ISSUE MARK