

SEC. A-A

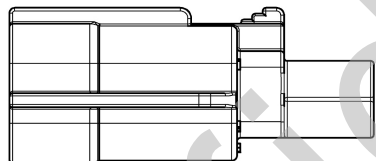
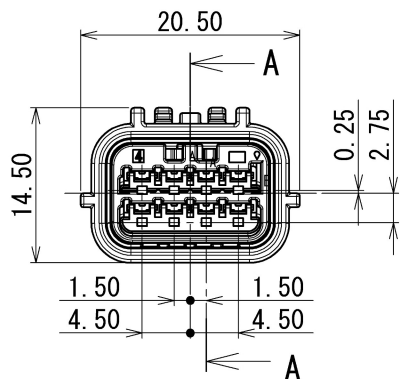

TABLE 1	SUB ASSEMBLY PART NO. AND CH. CODE	NO.	YAZAKI PART NO. AND CH. CODE	MATERIAL	COLOR	QTY.
△	7282-2148-30 ETC.	①	SEE TABLE 2	PBT	SEE TABLE 2	1
		②	7158-6348	PBT-G	NATURAL	1

TABLE 2	SUB ASSEMBLY PART NO. AND CH. CODE	YAZAKI PART NO. AND CH. CODE	COLOR
△	7282-2148-10	7182-2148-10	DARK GRAY
	7282-2148-30	7182-2148-30	BLACK

NOTES

- △ 1. MATING PART NO. : 7283-2148-30 ETC.
- 2. APPLICABLE TERMINAL NO. : 7114-4415-02, 7114-4416-02, 7114-4417-02.
- 3. APPLICABLE SEAL RUBBER NO. : 7158-3165-90, 7158-3166-60, 7158-3167-80, 7158-3168-80
- 4. APPLICABLE UNUSED CAVITY PLUG: 7158-3169-40

注記

- △ 1. かん合相手品番 : 7283-2148-30 ETC.
- 2. 適用端子品番 : 7114-4415-02, 7114-4416-02, 7114-4417-02
- 3. 適用ゴム栓品番 : 7158-3165-90, 7158-3166-60, 7158-3167-80
7158-3168-80
- 4. 適用防水栓品番 : 7158-3169-40

ISSUE MARK

△2	10/11/15	CHANGED PART NAME	C10-ZA97	J. C	CUSTOMER	MATL. SPEC.	SEE TABLE	TREAT. & FIN.
△1	05/09/29	ADDED COLOR PART NO., ETC.	C05-ZD46	K. N	CUSTOMER PART NO.	NAME △ HS 025 8P SEALED HOUSING		
	04/02/27	NEW	C04-X160	K. N	CUSTOMER DWG NO.	SUB ASSEMBLY MALE		
LET	DATE	REVISION RECORD	NO.	CHKD	OFFICE	PART NO. CH. CODE △ 7282-2148-30 ETC.		
GENERAL TOLERANCE					VENDOR	DWG NO. 7282-2148-30:R		
	10MAX	50MAX	100MAX	250MAX	2500VR	ANGLE	ECCENT	DWG TYPE
A	±0.15	±0.2	±0.3	±0.5	±0.75	±30'	O.1	R
B	±0.2	±0.3	±0.55	±0.95	±1.4	±30'	O.1	NEW
◎	±0.3	±0.5	±0.8	±1.4	±2	±30'	O.15	DWG DATE
SPECIFIED					APPROVED	CHECKED	CHECKED	DESIGN
MASS					S. MIZUSE	_____	R. CABANGAL	K. NI IHO
g					10/11/15	_____	10/11/15	J. CANDO
					UNIT	SCL	ANGLE	SET DWG NO.
					mm	2:1	3	7282-2148-30:R
					YAZAKI CORPORATION			