

1

2

3

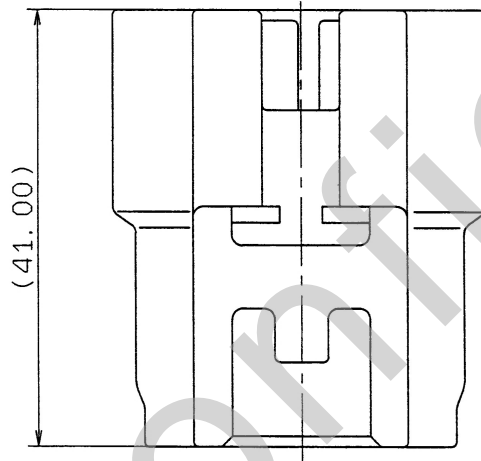
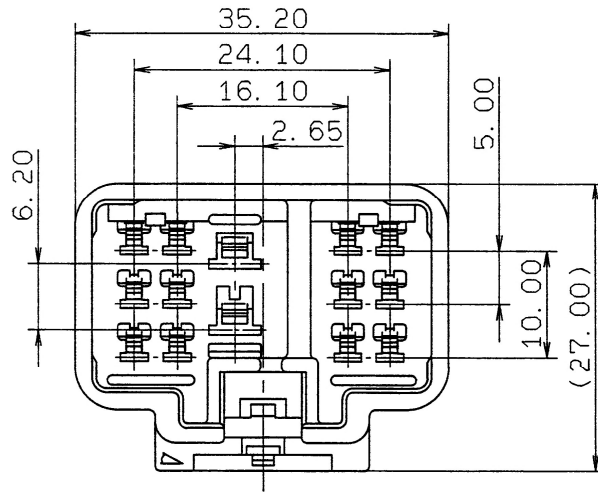
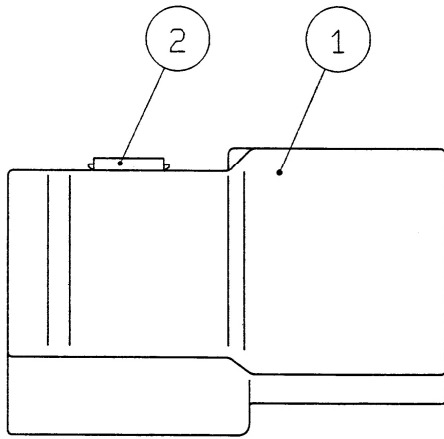

TABLE 1

YAZAKI SUB ASSEMBLY PART NO.	NO.	YAZAKI PART NO.	MATERIAL	COLOR	QTY.
7282-1148 ETC.	①	SEE TABLE 2	PBT	SEE TABLE 2	1
	②	7157-4055	PBT	NATURAL	1

TABLE 2

YAZAKI SUB ASSEMBLY PART NO.	YAZAKI PART NO.	COLOR
7282-1148	7182-1148	NATURAL
7282-1148-10	7182-1148-10	DARK GRAY
7282-1148-30	7182-1148-30	BLACK
7282-1148-40	7182-1148-40	LIGHT GRAY
7282-1148-50	7182-1148-50	ORANGE
7282-1148-60	7182-1148-60	GREEN
7282-1148-80	7182-1148-80	BROWN
7282-1148-90	7182-1148-90	BLUE

注記

1. 嵌合相手品番: 7283-1148 ETC.

NOTE

1. MATING PART NO. : 7283-1148 ETC.

ISSUE MARK

CUSTOMER										MATL. SPEC.			TREAT. & FIN.			
CUSTOMER PART NO.					CUSTOMER DWG NO.					SEE TABLE 1						
97.09.17 NEW C97-M978 M. T OFFICE										NAME			090II 12P 187 2P HYBRID			
LET DATE REVISION RECORD NO. CHKD VENDOR										TRIAL PART NO.			-----			
GENERAL TOLERANCE										VENDOR NO.					CONNECTOR SUB ASSEMBLY MALE	
	10MAX	50MAX	100MAX	250MAX	250OVR	ANGLE	ECCENT	DWG TYPE	DWG SOURCE	DWG DATE	UNIT	SCL	ANGLE	PART NO.	7282-1148 ETC.	
A	±0.15	±0.2	±0.3	±0.5	±0.75	±30'	0.1	R	NEW	97.09.17	mm	2/1	3	CH. CODE	7282-1148 ETC.	
B	±0.2	±0.3	±0.55	±0.95	±1.4	±30'	0.1	APPROVED	CHECKED	CHECKED	DESIGN	DRAWN	DWG NO.	7282-1148:R	SET DWG NO.	
©	±0.3	±0.5	±0.8	±1.4	±2	±30'	0.15	加藤 山梨 栄田		Y. OHTA	ITOH 田中 34		YAZAKI CORPORATION			
SPECIFIED						MASS		g		97.09.25	97.09.24	97.09.22	89.08.18	97.09.17		

1

2

3