

B

B

A

A

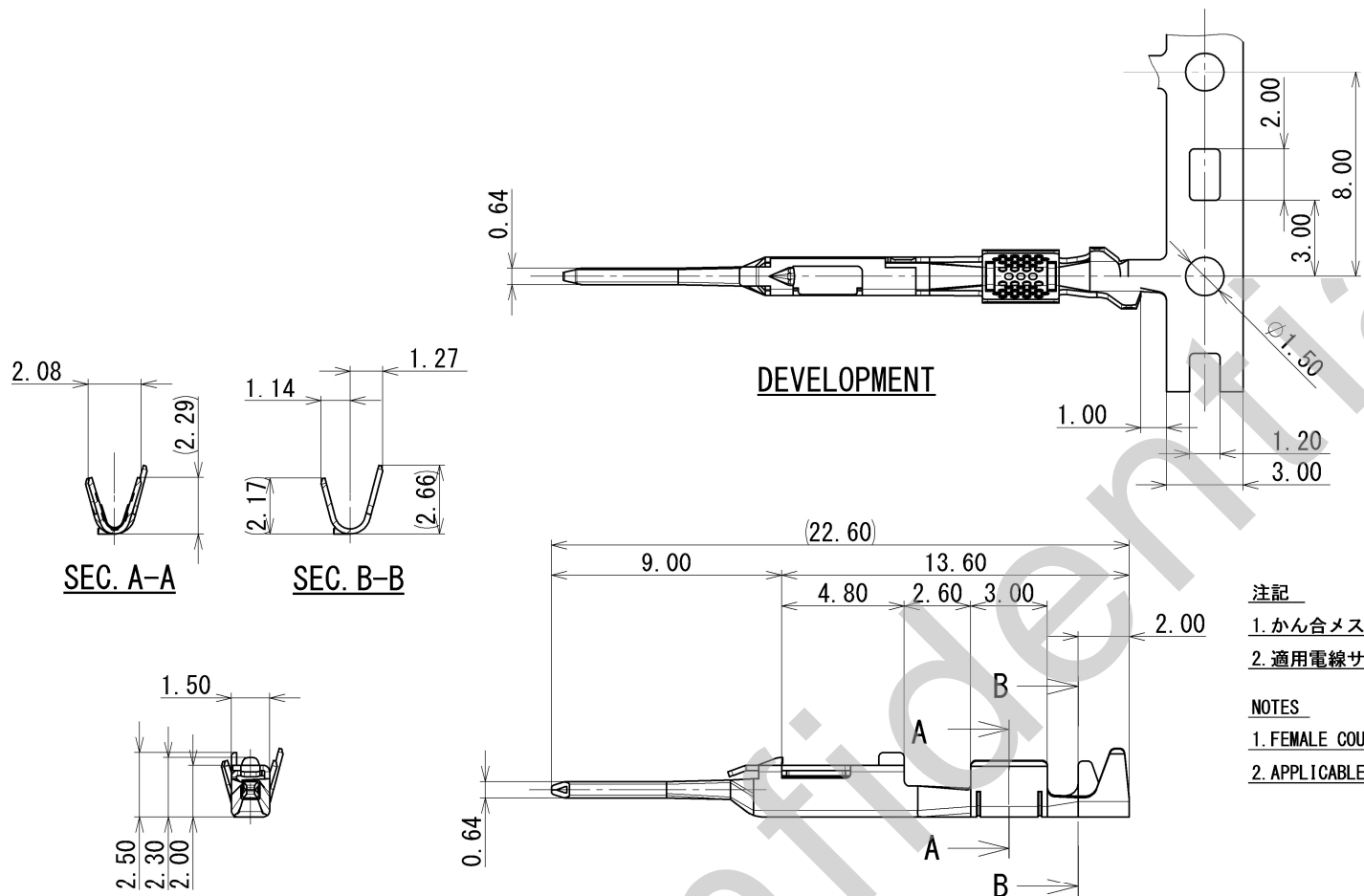

DEVELOPMENT

注記

- 1. かん合メス端子品番 : 7196-0158-02
- 2. 適用電線サイズ : CAVUS 0.3~CAVS 0.5

NOTES

- 1. FEMALE COUNTERPART NO. : 7196-0158-02
- 2. APPLICABLE WIRE SIZE : CAVUS 0.3 ~ CAVS 0.5

GENERAL TOLERANCE											
	10 MAX	50 MAX	100 MAX	250 MAX	250 OVR	R5 MAX	R10 MAX	R20 MAX	R20 OVR	ANGLE	ECCENT
A	±0.15	±0.2	±0.3	±0.5	±0.75					±3°	0.1
B	±0.2	±0.3	±0.55	±0.95	±1.4	±0.2	±0.3	±0.5	±2.5	±3°	0.1
◎	±0.3	±0.5	±0.8	±1.4	±2					±3°	0.15

ISSUE MARK

				CUSTOMER				MATL. SPEC.				TREAT. & FIN.																							
				CUSTOMER PART NO.				BRASS (t=0.20)				TIN PLATING																							
				CUSTOMER DWG NO.				NAME 0.64 TERMINAL MALE																											
2014/08/27				NEW				C14-P174				D. J																							
LET				DATE				REVISION RECORD				NO.																							
GENERAL TOLERANCE												VENDOR NO.																							
												DWG TYPE				DWG SOURCE				DWG DATE				UNIT				SCL				ANGLE			
A												R				NEW				2014/08/27				mm				5:1				3			
B												APPROVED				CHECKED				DESIGN				DRAWN											
C												S. CHIBA				Y. WADA				Y. WADA				D. JIN											
SPECIFIED												2014/08/27				2014/08/27				2014/07/01				2014/08/27											
MASS																																			
												PART NO. 7195-0157-02				DWG NO. 7195-0157-02:R				SET DWG NO.															
												YAZAKI CORPORATION																							