

RUBBER PART GENERAL TOLERANCE				
PART DIM.	1	2	③	
0 TO 3	± 0.2	± 0.3	± 0.4	
3 TO 6	± 0.2	± 0.4	± 0.5	
6 TO 10	± 0.3	± 0.5	± 0.6	
10 TO 18	± 0.3	± 0.6	± 0.8	
18 TO 30	± 0.4	± 0.8	± 1.0	
30 TO 50	± 0.5	± 1.0	± 1.5	
50 TO 80	± 0.6	± 1.2	± 2.0	
80 TO 120	± 0.7	± 1.4	± 2.5	
120 TO 180	± 0.8	± 1.6	± 3.0	
180 TO 250	± 1.0	± 2.0	± 4.0	
250 TO 315	± 1.2	± 2.5	± 5.0	
315 TO 400	± 1.5	± 3.0	± 6.0	
400 TO 500	± 1.8	± 3.5	± 7.0	
500 OVER	± 0.4 %	± 0.8 %	± 1.5 %	

PART NO. AND CH. CODE	NO.	PART NO. AND CH. CODE	MATERIAL	COLOR	QTY.
7158-3180-80	①	7158-4042-40	PBT	LIGHT GRAY	1
	②		SILICONE RUBBER	BROWN	1

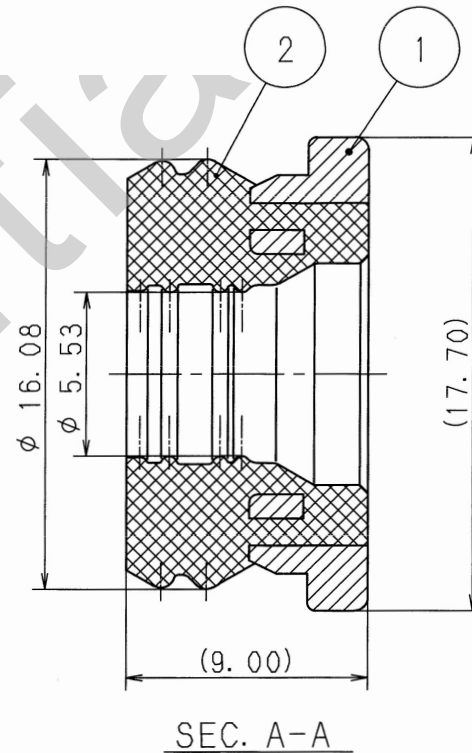
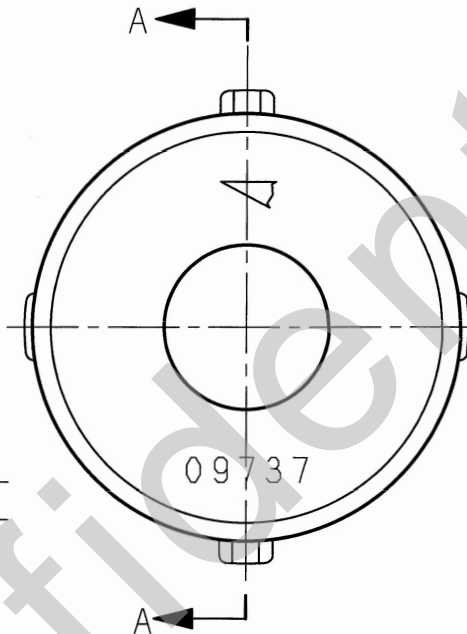

注記

1. 適用電線サイズ : AVX, AVXF 15sq
(標準仕上り外形φ7.00~φ8.00)

NOTE

1. APPLICABLE WIRE SIZE : AVX, AVXF 15sq
(NOMINAL DIAMETER OF FINISHED CABLE φ7.00~φ8.00)

ISSUE MARK

				CUSTOMER		MATL. SPEC.		TREAT. & FIN.							
				CUSTOMER PART NO.		SEE TABLE									
				CUSTOMER DWG NO.		NAME T9.5 (375) SEALED									
01.06.28	NEW	C01-X637	S. K	OFFICE	TRIAL PART NO.	REAR HOLDER+RUBBER STOPPER (L)									
LET	DATE	REVISION RECORD	NO.	CHKD	VENDOR										
GENERAL TOLERANCE				VENDOR NO.											
10MAX	50MAX	100MAX	250MAX	2500VR	ANGLE	ECCENT	DWG TYPE	DWG SOURCE	DWG DATE	UNIT	SCL	ANGLE	PART NO.		
±0.15	±0.2	±0.3	±0.5	±0.75	±30'	0.1	R	NEW	01.06.28	mm	5/1	3	7158-3180-80		
±0.2	±0.3	±0.55	±0.95	±1.4	±30'	0.1	APPROVED	CHECKED	CHECKED	DESIGN	DRAWN		DWG NO.		
±0.3	±0.5	±0.8	±1.4	±2	±30'	0.15	加藤	山梨	鳥居	H. TANISHITA	OHKUBO		7158-3180-80:R		
SPECIFIED				MASS		01.07.06		01.07.04		01.07.02		96.09.19		01.06.28	
				g		01.07.06		01.07.04		01.07.02		96.09.19		01.06.28	
												YAZAKI CORPORATION			