

1

2

3

RUBBER PART GENERAL TOLERANCE			
PART DIM.	1	2	③
0 TO 3	± 0.2	± 0.3	± 0.4
3 TO 6	± 0.2	± 0.4	± 0.5
6 TO 10	± 0.3	± 0.5	± 0.6
10 TO 18	± 0.3	± 0.6	± 0.8
18 TO 30	± 0.4	± 0.8	± 1.0
30 TO 50	± 0.5	± 1.0	± 1.5
50 TO 80	± 0.6	± 1.2	± 2.0
80 TO 120	± 0.7	± 1.4	± 2.5
120 TO 180	± 0.8	± 1.6	± 3.0
180 TO 250	± 1.0	± 2.0	± 4.0
250 TO 315	± 1.2	± 2.5	± 5.0
315 TO 400	± 1.5	± 3.0	± 6.0
400 TO 500	± 1.8	± 3.5	± 7.0
500 OVER	± 0.4%	± 0.8%	± 1.5%

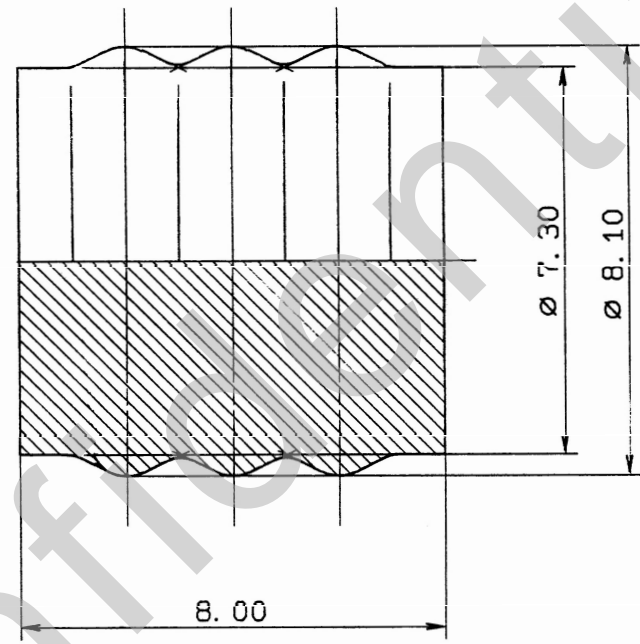
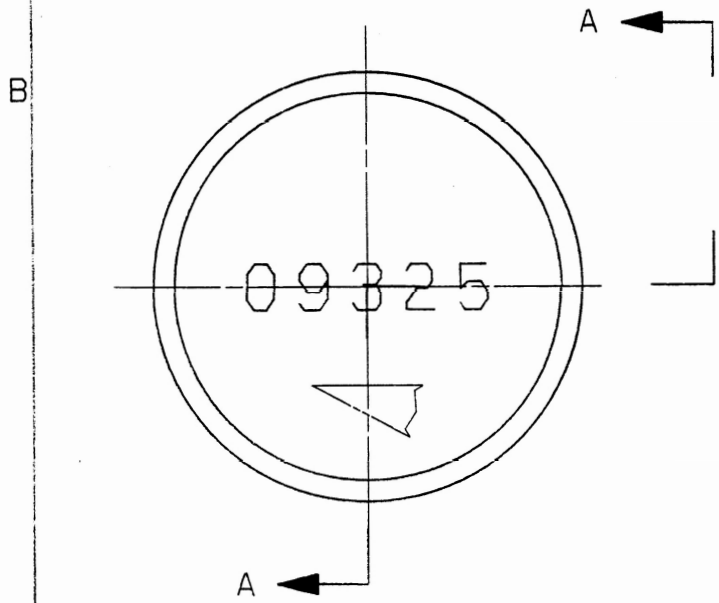

注記

- 1. 色：濃灰色トスル。
- 2. 材料：含油NBR

NOTES

- 1. COLOR : DARK GRAY
- 2. MATI & SPEC ; SELF-LUBRICATING. NBR

ISSUE MARK

				CUSTOMER				MATT. SPEC.				TREAT. & FIN.			
				CUSTOMER PART NO.				SEE NOTES							
				CUSTOMER DWG NO.				NAME				187 PLUGGING RUBBER			
90.10.01				NEW				C90-M079 T. S				STDLIB NO.			
LET	DATE	REVISION RECORD	NO.	CHKD	VENDOR				STOPPER						
GENERAL TOLERANCE								VENDOR NO.							
10MAX	50MAX	100MAX	250MAX	250OVR	ANGLE	ECCENT	DWG TYPE	DWG SOURCE	DWG DATE	UNIT	SCL	ANGLE	PART NO.		
A	±0.15	±0.2	±0.3	±0.5	±30'	0.1	R	NEW	90.10.01	mm	10/1	3	7157-8763		
B	±0.2	±0.3	±0.55	±0.95	±30'	0.1	APPROVED	CHECKED	CHECKED	DESIGN	DRAWN	DWG NO.			
C	±0.3	±0.5	±0.8	±1.4	±30'	0.15				M. TSUJI	T. MAKITA	7157-8763:R			
SPECIFIED				WEIGHT				YAZAKI CORPORATION				TRIAL PART NO.			
RUBBER PART GENERAL TOLERANCE 3				g				90.11.02 90.11.02 90.10.31 90.10.01							

1

2

3