

1

2

3

⚠	PART NO. AND CH. CODE	MATERIAL	COLOR	APPLICABLE PART NO.
	7157-6520-80	PA66	BROWN	7122-1824-40 ETC. 7223-1824-40 ETC.

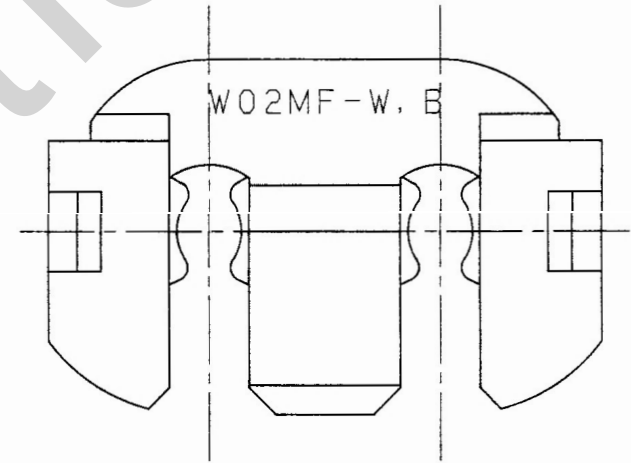
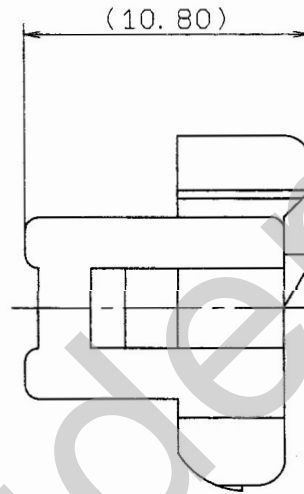
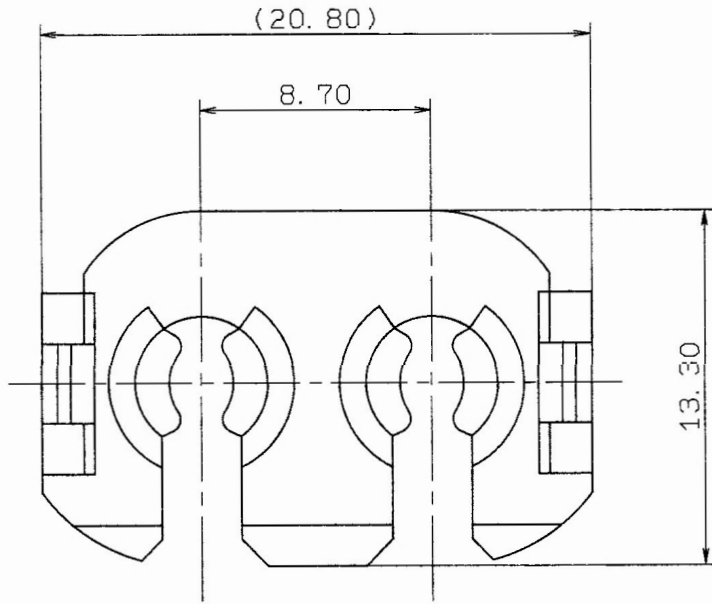

ISSUE MARK

⚠	99.09.16	ADDED APPLICABLE PART NO.	C99-M404	H. K	CUSTOMER	CUSTOMER PART NO.	CUSTOMER DWG NO.	MATL. SPEC.	SEE TABLE	TREAT. & FIN.						
	88.12.12	NEW	8MC-3185	T. M	OFFICE	TRIAL PART NO.		NAME	REAR HOLDER FOR							
LET	DATE	REVISION RECORD	NO.	CHKD	VENDOR				W TYPE CONNECTOR 2PM. FW, B							
GENERAL TOLERANCE					VENDOR NO.											
	10MAX	50MAX	100MAX	250MAX	250OVR	ANGLE	ECCENT	DWG TYPE	DWG SOURCE	DWG DATE	UNIT	SCL	ANGLE	PART NO.	7157-6520-80	
A	±0.15	±0.2	±0.3	±0.5	±0.75	±30'	0.1	R	NEW	88.10.24	mm	5/1	3	CH. CODE		
B	±0.2	±0.3	±0.55	±0.95	±1.4	±30'	0.1	APPROVED	CHECKED	CHECKED	DESIGN	DRAWN	DWG NO.	7157-6520-80:R	SET DWG NO.	
©	±0.3	±0.5	±0.8	±1.4	±2	±30'	0.15				SATOH	MIYAZAKI				
SPECIFIED					MASS	g		99.09.28		99.09.20			84.11.29	99.09.16	YAZAKI CORPORATION	

1

2

3