

NO.	YAZAKI PART NO.	COLOR
1	7157-6023-90	LIGHT BLUE
2	7157-6023-30	BLACK

注記

△ 1) 適用ハウジング品番: 7123-1629-90 ETC.

NOTE

△ 1) APPLICABLE HOUSING NO. : 7123-1629-90 ETC.

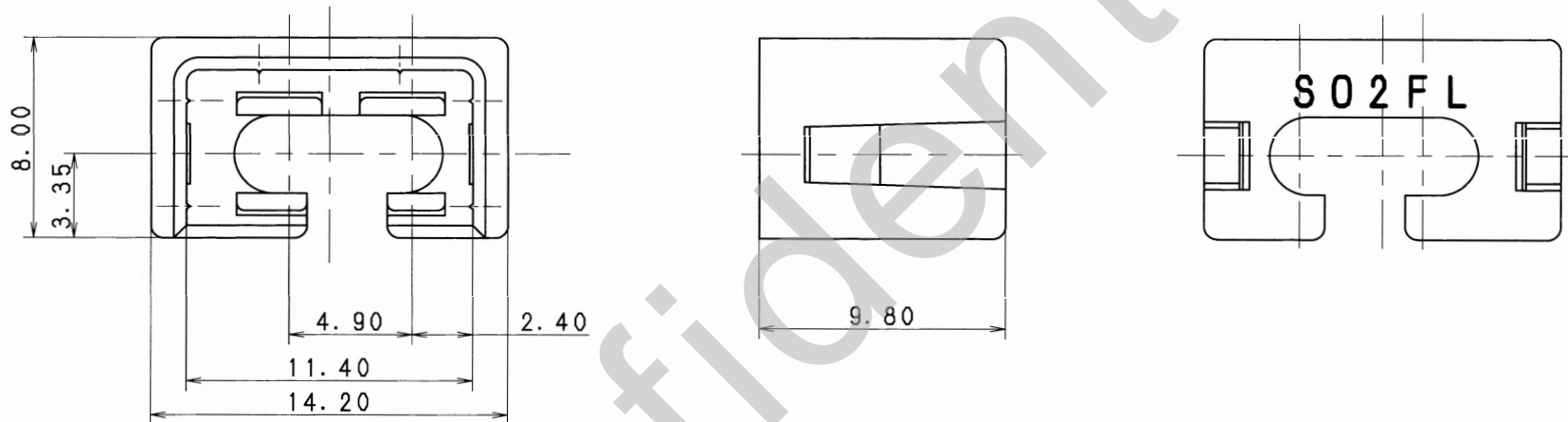

ISSUE MARK

			CUSTOMER				MATL. SPEC. NYLON 6				TREAT. & FIN.				
			CUSTOMER PART NO.				CUSTOMER DWG NO.								
△	96.09.30	ADDED PART NO.	C96-M822	H. K					NAME REAR HOLDER						
	88.11.01	NEW	8MC-3164	T. M	OFFICE				TRIAL PART NO.						
LET	DATE	REVISION RECORD	NO.	CHKD	VENDOR				FOR S02FL						
GENERAL TOLERANCE					VENDOR NO.										
	10MAX	50MAX	100MAX	250MAX	2500VR	ANGLE	ECCENT	DWG TYPE	DWG SOURCE	DWG DATE	UNIT	SCL	ANGLE	PART NO.	△7157-6023-90 ETC.
A	±0.15	±0.2	±0.3	±0.5	±0.75	±30'	0.1	R	NEW	88.10.15	mm	5/1	3	CH. CODE	
B	±0.2	±0.3	±0.55	±0.95	±1.4	±30'	0.1	APPROVED	CHECKED	CHECKED	DESIGN	DRAWN		DWG NO.	7157-6023-90:R
©	±0.3	±0.5	±0.8	±1.4	±2	±30'	0.15	神田		渡辺	SAKAI	MOTOHASHI		YAZAKI CORPORATION	
SPECIFIED					MASS		g	96.10.4		96.10.3	82.08.02	96.10.3			