

SEC. A-A

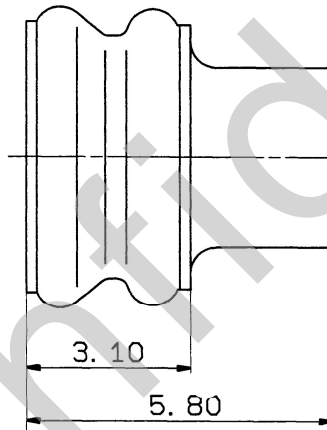

RUBBER PART GENERAL TOLERANCE			
PART DIM.	1	2	③
0 TO 3	± 0.2	± 0.3	± 0.4
3 TO 6	± 0.2	± 0.4	± 0.5
6 TO 10	± 0.3	± 0.5	± 0.6
10 TO 18	± 0.3	± 0.6	± 0.8
18 TO 30	± 0.4	± 0.8	± 1.0
30 TO 50	± 0.5	± 1.0	± 1.5
50 TO 80	± 0.6	± 1.2	± 2.0
80 TO 120	± 0.7	± 1.4	± 2.5
120 TO 180	± 0.8	± 1.6	± 3.0
180 TO 250	± 1.0	± 2.0	± 4.0
250 TO 315	± 1.2	± 2.5	± 5.0
315 TO 400	± 1.5	± 3.0	± 6.0
400 TO 500	± 1.8	± 3.5	± 7.0
500 OVER	± 0.4 %	± 0.8 %	± 1.5 %

注記

- 1) 色; ライトグ* リーン
- 2) 材料; 含油NBR
- 3) 適用電線サイズ*; 仕上り外径 ϕ 1.40~ ϕ 2.00トスル.

NOTES

- 1) COLOR: LIGHT GREEN
- 2) MATL&SPEC; SELF-LUBRICATING, NBR.
- 3) APPLICABLE WIRE SIZE; DIAMETER OF FINISHED CABLE ϕ 1.40~ ϕ 2.00

ISSUE MARK

										CUSTOMER				MATL. SPEC. SEE NOTES		TREAT. & FIN.	
										CUSTOMER PART NO.				CUSTOMER DWG NO.			
- 92.07.23 NEW C92-6506 H. Y										OFFICE				TRIAL PART NO.			
LET DATE REVISION RECORD NO. CHKD										VENDOR				VENDOR NO.			
GENERAL TOLERANCE										DWG TYPE				DWG SOURCE			
										R				NEW			
										92.07.23				mm			
10MAX 50MAX 100MAX 250MAX 250QVR ANGLE ECCENT										DWG DATE				UNIT			
A ±0.15 ±0.2 ±0.3 ±0.5 ±0.75 ±30' 0.1										92.07.23				mm			
B ±0.2 ±0.3 ±0.55 ±0.95 ±1.4 ±30' 0.1										APPROVED				DESIGN			
C ±0.3 ±0.5 ±0.8 ±1.4 ±2 ±30' 0.45										CHECKED				DRAWN			
SPECIFIED										E. SUZUKI				矢部			
MASS										92.7.27				92.7.24			
										92.07.23				91.12.23			
										92.07.23				92.07.23			
										7157-3857-60				7157-3857-60:R			
										YAZAKI CORPORATION							