

1

2

3

| RUBBER PART GENERAL TOLERANCE | | | | |
|-------------------------------|---------|---------|---------|--|
| PART DIM. | 1 | 2 | ③ | |
| 0 TO 3 | ± 0.2 | ± 0.3 | ± 0.4 | |
| 3 TO 6 | ± 0.2 | ± 0.4 | ± 0.5 | |
| 6 TO 10 | ± 0.3 | ± 0.5 | ± 0.6 | |
| 10 TO 18 | ± 0.3 | ± 0.6 | ± 0.8 | |
| 18 TO 30 | ± 0.4 | ± 0.8 | ± 1.0 | |
| 30 TO 50 | ± 0.5 | ± 1.0 | ± 1.5 | |
| 50 TO 80 | ± 0.6 | ± 1.2 | ± 2.0 | |
| 80 TO 120 | ± 0.7 | ± 1.4 | ± 2.5 | |
| 120 TO 180 | ± 0.8 | ± 1.6 | ± 3.0 | |
| 180 TO 250 | ± 1.0 | ± 2.0 | ± 4.0 | |
| 250 TO 315 | ± 1.2 | ± 2.5 | ± 5.0 | |
| 315 TO 400 | ± 1.5 | ± 3.0 | ± 6.0 | |
| 400 TO 500 | ± 1.8 | ± 3.5 | ± 7.0 | |
| 500 OVER | ± 0.4 % | ± 0.8 % | ± 1.5 % | |

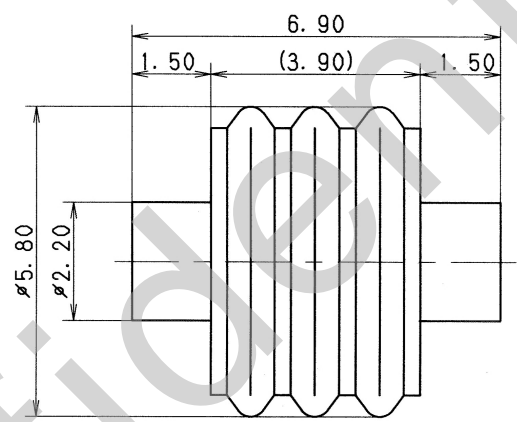
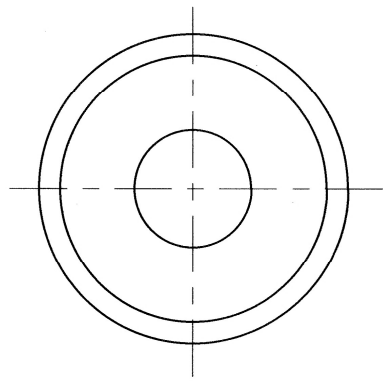

注記

1) 本製品は、SWPコネクタのメクラ栓として使用する。

△ NOTE

1) THIS PRODUCT IS USED AS A DUMMY PLUG OF SWP CONNECTOR.

ISSUE MARK

| | | | | | | | | | | | | | | | | | | | | | | | | | | | | | | | | | | | | | | | | | | | | |
|--------------------|--|--|--|--|-------------------------------|--|--|--|--|--|--|--|--|--|------------------------|--|--|--|--|----------|--|--|--|--|-------------|--|--|--|--|-------------|--|--|--|--|--------|--|--|--|--|--|--|--|--|--|
| | | | | | CUSTOMER | | | | | MATL. SPEC. SELF-LUBRICATING SILICONE RUBBER | | | | | TREAT. & FIN. | | | | | | | | | | | | | | | | | | | | | | | | | | | | | |
| | | | | | CUSTOMER PART NO. | | | | | CUSTOMER DWG NO. | | | | | | | | | | | | | | | | | | | | | | | | | | | | | | | | | | |
| △ 06/06/23 | | | | | ADDED GENERAL TOLERANCE, ETC. | | | | | C06-Z706 | | | | | E. S | | | | | | | | | | | | | | | | | | | | | | | | | | | | | |
| 87/04/08 | | | | | NEW | | | | | 7MC-0173 | | | | | M. K | | | | | | | | | | | | | | | | | | | | | | | | | | | | | |
| LET | | | | | DATE | | | | | REVISION RECORD | | | | | NO. | | | | | CHKD | | | | | | | | | | | | | | | | | | | | | | | | |
| GENERAL TOLERANCE | | | | | | | | | | | | | | | VENDOR NO. | | | | | | | | | | | | | | | | | | | | | | | | | | | | | |
| | | | | | 10MAX | | | | | 50MAX | | | | | 100MAX | | | | | 250MAX | | | | | 2500VR | | | | | ANGLE | | | | | ECCENT | | | | | | | | | |
| A | | | | | ±0.15 | | | | | ±0.2 | | | | | ±0.3 | | | | | ±0.5 | | | | | ±0.75 | | | | | ±30' | | | | | 0.1 | | | | | | | | | |
| B | | | | | ±0.2 | | | | | ±0.3 | | | | | ±0.55 | | | | | ±0.95 | | | | | ±1.4 | | | | | ±30' | | | | | 0.1 | | | | | | | | | |
| C | | | | | ±0.3 | | | | | ±0.5 | | | | | ±0.8 | | | | | ±1.4 | | | | | ±2 | | | | | ±30' | | | | | 0.15 | | | | | | | | | |
| SPECIFIED | | | | | | | | | | | | | | | MASS | | | | | | | | | | | | | | | | | | | | | | | | | | | | | |
| | | | | | | | | | | | | | | | g | | | | | | | | | | | | | | | | | | | | | | | | | | | | | |
| | | | | | I / m | | | | | — | | | | | 鈴木 (姓) | | | | | YAMADA | | | | | C. AGCAOILI | | | | | | | | | | | | | | | | | | | |
| | | | | | 06.6.27 | | | | | 06.06.26 | | | | | 86/02/05 | | | | | 06/06/23 | | | | | | | | | | | | | | | | | | | | | | | | |
| | | | | | | | | | | | | | | | PART NO. 7157-3755-60 | | | | | | | | | | | | | | | CH. CODE | | | | | | | | | | | | | | |
| | | | | | | | | | | | | | | | DWG NO. 7157-3755-60:R | | | | | | | | | | | | | | | SET DWG NO. | | | | | | | | | | | | | | |
| YAZAKI CORPORATION | | | | | | | | | | | | | | | | | | | | | | | | | | | | | | | | | | | | | | | | | | | | |

1

2

3