

PART NO. AND CH. CODE	COLOR
7123-8386 (7B23-8386)	NATURAL
7123-8386-30	BLACK
7123-8386-70	YELLOW

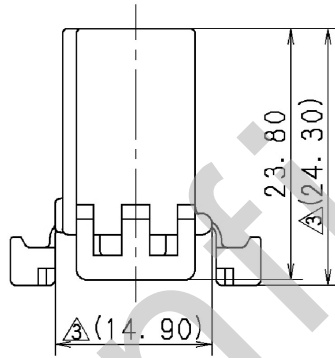
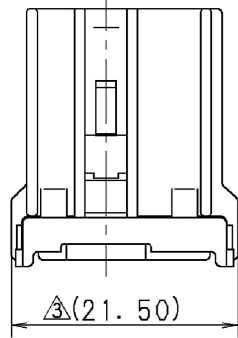
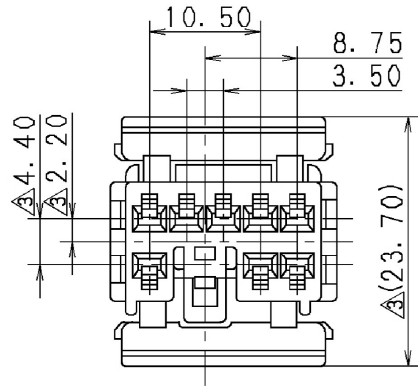

注記

- 1. かん合相手品番: 7122-8386 ETC.
- 2. 適用端子品番: 7116-1473 (7B16-1473), 7116-1473-08, 7116-1474, 7116-1474-08
- 3. () 内品番は、エアバッグ回路及び特別管理回路使用時に適用する事。

NOTES

- 1. MATING PART NO. : 7122-8386 ETC.
- 2. APPLICABLE TERMINAL NO. : 7116-1473 (7B16-1473), 7116-1473-08, 7116-1474, 7116-1474-08
- 3. () PART NO. IS USED FOR PARTS ASSOCIATED WITH A/B CIRCUITS OR OTHER SPECIFIED CIRCUIT.

ISSUE MARK

10.11.15	CHANGED PART NAME	C10-ZA96	R. M	CUSTOMER	MATL. SPEC.	PBT	TREAT. & FIN.
03.09.22	ADDED PART NO.	C03-X585	T. H	CUSTOMER PART NO.	CUSTOMER DWG NO.		
92.11.18	ADDED PART No.	C92-6964	K. S				
92.07.23	RENEW	C92-6717	A. H	OFFICE	TRJAL PART NO.		
LET	REVISION RECORD	NO.	CHKD	VENDOR			
GENERAL TOLERANCE				VENDOR NO.	NAME 7123-8386 (7B23-8386) ETC.		
	10MAX	50MAX	100MAX	250MAX	250OVR	ANGLE	ECCENT
A	±0.15	±0.2	±0.3	±0.5	±0.75	±30'	0.1
B	±0.2	±0.3	±0.55	±0.95	±1.4	±30'	0.1
C	±0.3	±0.5	±0.8	±1.4	±2	±30'	0.15
SPECIFIED				MASS	DWG TYPE	DWG SOURCE	DWG DATE
					R	NEW	88.07.04
					APPROVED	CHECKED	CHECKED
					S. MIZUSE		R. CABANGAL
					10.11.15		10.11.15
					H. SAITOH	R. MAJERANO	
					88.07.04	10.11.15	
					PART NO. 7123-8386 (7B23-8386) ETC.		
					CH. CODE 7123-8386 : R		
					DWG NO. 7123-8386 : R		
					SET DWG NO.		
					YAZAKI CORPORATION		