

1

2

3

△ NOTES

- 1) MATING HOUSING NO. :7122-7830
- 2) APPLICABLE TERMINAL NO. :7116-1300etc.

注記

- 1) かん合相手品番:7122-7830
- 2) 使用端子品番:7116-1300 etc.

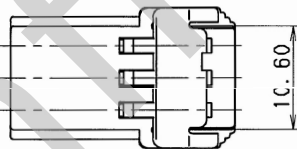
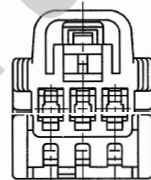
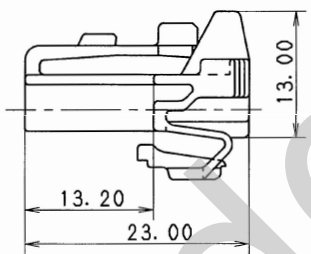
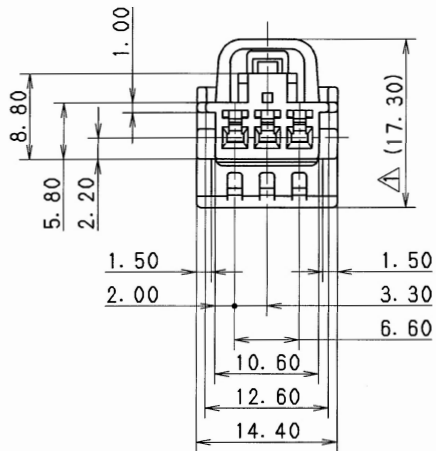
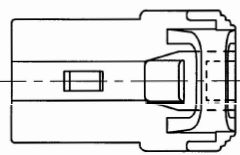

ISSUE MARK

CUSTOMER										MATT. PBT (NATURAL)			TREAT. & FIN.	
CUSTOMER PART NO.					CUSTOMER DWG NO.					SPEC.				
△	10.11.15	CHANGED PART NAME	C10-ZA95	G. M						NAME △ C TYPE 3P FEMALE HOUSING				
△	92.09.16	RENEW	C92-6909	M. K	OFFICE					TRIAL PART NO.				
LET	DATE	REVISION RECORD	NO.	CHKD	VENDOR					VENDOR NO.				
GENERAL TOLERANCE										PART NO. 7123-7830				
	10MAX	50MAX	100MAX	250MAX	250OVR	ANGLE	ECCENT	DWG TYPE	DWG SOURCE	DWG DATE	UNIT	SCL	ANGLE	DWG NO. 7123-7830:R
A	±0.15	±0.2	±0.3	±0.5	±0.75	±30'	0.1	R	RENEW	87.12.22	mm	2/1	3	
B	±0.2	±0.3	±0.55	±0.95	±1.4	±30'	0.1	APPROVED	CHECKED	CHECKED	DESIGN	DRAWN		
©	±0.3	±0.5	±0.8	±1.4	±2	±30'	0.15	S. MIZUSE		R. CABANGAL	TSUKAMOTO	G. MAGNAYON		YAZAKI CORPORATION
SPECIFIED							MASS	10.11.15		10.11.15	87.02.18	10.11.15		

1

2

3

