

1

2

3

PART NO. AND CH. CODE	COLOR
7123-6337, $\boxtimes$	NATURAL
7123-6337-40, $\boxtimes$	GRAY

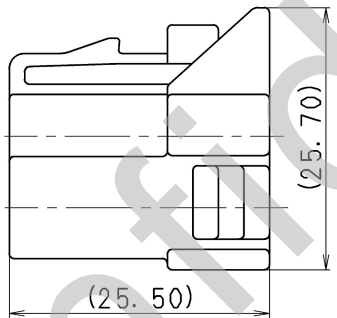
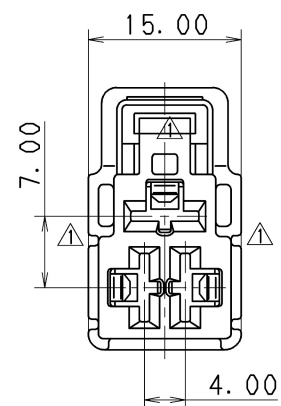
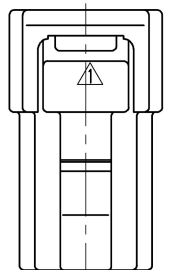

注記

- 1. 材質: PBT
- 2. かん合相手品番: 7122-6337 ETC.
- 3. 適用端子品番: 7116-2990-02 ETC.

NOTES

- 1. MATERIAL: PBT
- 2. MATING PART NO.: 7122-6337 ETC.
- 3. APPLICABLE TERMINAL NO.: 7116-2990-02 ETC.

ISSUE MARK

$\boxtimes$	10. 11. 15	CHANGED PART NAME	C10-ZB06	G. M	CUSTOMER	MATL. SPEC.	SEE NOTES	TREAT. & FIN.
$\boxtimes$	00. 12. 13	CHANGED FORM, $\boxtimes$	C00-M585	H. Y	CUSTOMER PART NO.	CUSTOMER DWG NO.		
$\boxtimes$	99. 11. 16	CHANGED FORM ETC.	C99-M694	H. Y			NAME $\boxtimes$ M-LC TYPE HOUSING	
	99. 07. 13	NEW	C99-M181	H. Y	OFFICE	TRIAL PART NO.	FEMALE 3P (W, GY)	
LET	DATE	REVISION RECORD	NO.	CHKD	VENDOR			
GENERAL TOLERANCE						VENDOR NO.		
	10MAX	50MAX	100MAX	250MAX	2500VR	ANGLE	ECCENT	DWG TYPE
A	$\pm 0.15$	$\pm 0.2$	$\pm 0.3$	$\pm 0.5$	$\pm 0.75$	$\pm 30'$	0.1	R
B	$\pm 0.2$	$\pm 0.3$	$\pm 0.55$	$\pm 0.95$	$\pm 1.4$	$\pm 30'$	0.1	APPROVED
$\text{\textcircled{C}}$	$\pm 0.3$	$\pm 0.5$	$\pm 0.8$	$\pm 1.4$	$\pm 2$	$\pm 30'$	0.15	CHECKED
SPECIFIED						MASS		CHECKED
								CHECKED
								DESIGN
								DRAWN
								S. MIZUSE
								R. CABANGAL
								YOSHIDA
								G. MAGNAYON
								10. 11. 15
								10. 11. 15
								99. 06. 07
								10. 11. 15
						PART NO. 7123-6337 ETC.		
						DWG NO. 7123-6337:R		
						SET DWG NO.		
YAZAKI CORPORATION								

1

2

3