

注 配

1) 嵌合オスハウジング品番: 7222-6244-40

2) 適用端子品番: 7123-2873, -2874

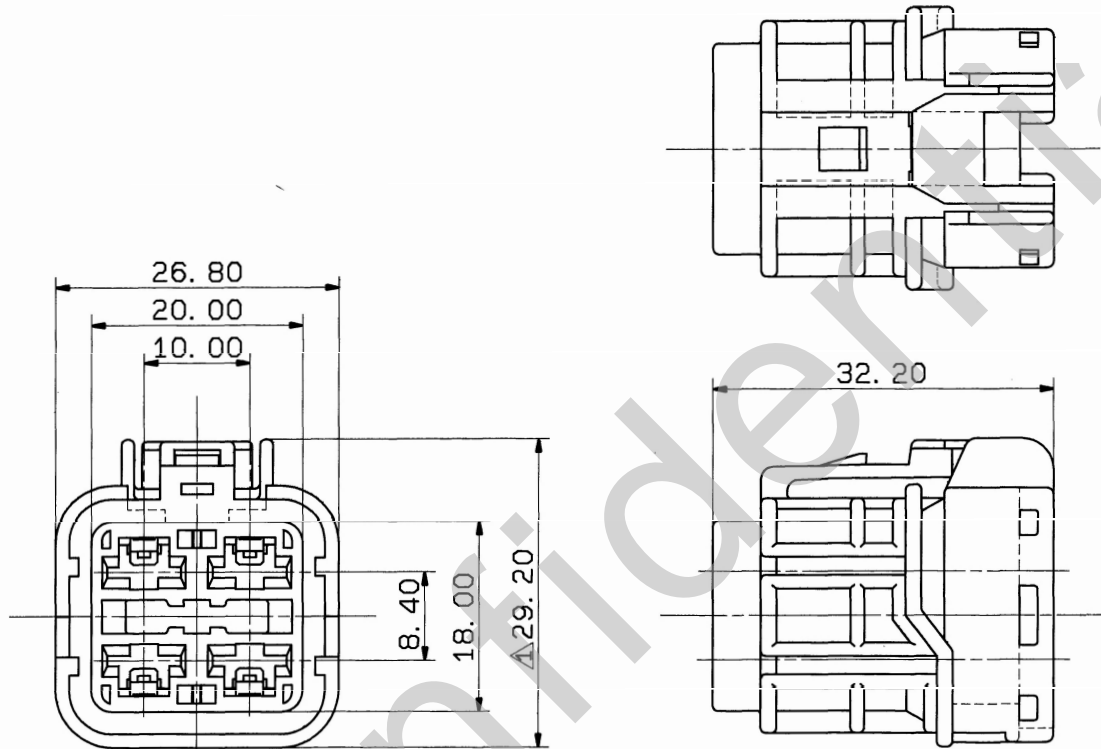

ISSUE MARK

▲ 94.06.29		CORRECTION OF A CLERICAL ERROR		C94-L902	M. T	CUSTOMER		MATL. PBT		TREAT. & FIN.					
87.11.12		NEW		7MC-4118	T. M	CUSTOMER PART NO.		CUSTOMER DWG NO.		NAME					
LET	DATE	REVISION RECORD		NO.	CHKD	OFFICE		TRIAL PART NO.		X タイプ コネクタ ハウジング					
						VENDOR		087623-4039		4PF(GY)					
GENERAL TOLERANCE						VENDOR NO.									
	10MAX	50MAX	100MAX	250MAX	250OVR	ANGLE	ECCENT	DWG TYPE	DWG SOURCE	DWG DATE	UNIT	SCL	ANGLE	PART NO.	7123-6244-40
A	±0.15	±0.2	±0.3	±0.5	±0.75	±30'	0.1	R	NEW	87.11.12	mm	2/1	3	CH. CODE	
B	±0.2	±0.3	±0.55	±0.95	±1.4	±30'	0.1	APPROVED	CHECKED	CHECKED	DESIGN	DRAWN	DWG NO.	7123-6244-40:R	
©	±0.3	±0.5	±0.8	±1.4	±2	±30'	0.15	酒井 増田 竹下		T. MASUDA KAJIKAWA		YAZAKI CORPORATION			
SPECIFIED						MASS		g		194.07.11 94.7.7 94.07.09		87.11.12 94.06.29			