

1

2

3

| YAZAKI PART NO. | MATERIAL | A | B | C | D | E | APPLICABLE WIRE SIZE |
|-----------------|--------------|------|------|------|------|------|------------------------------|
| 7116-2641 | BRASS t=0.32 | 3.50 | 3.70 | 4.90 | 5.50 | 1.10 | △ AVSS 0.75~AVS 2 EQUIVALENT |
| 7116-2642 | BRASS t=0.32 | 4.50 | 4.70 | 5.90 | 6.50 | 1.40 | △ AVS 3 |

B

B

A

A

F ← G ←

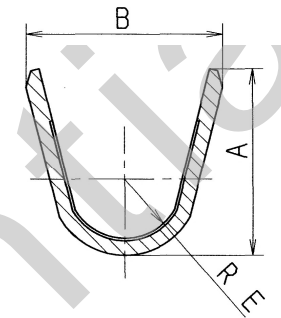
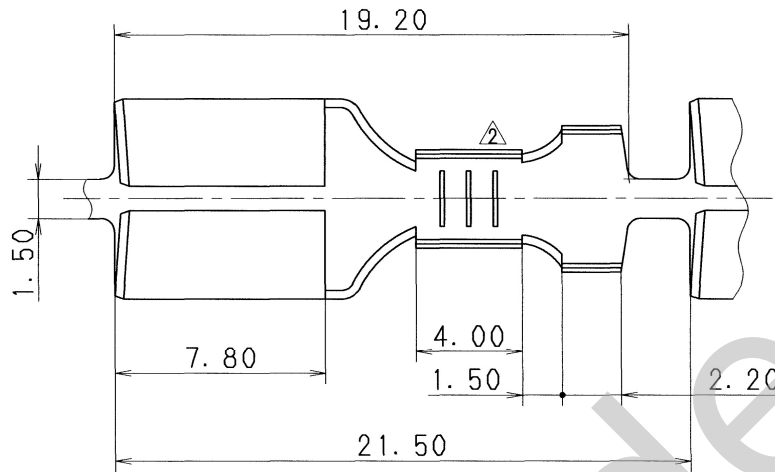

SEC. F-F (10/1)

F ← G ←

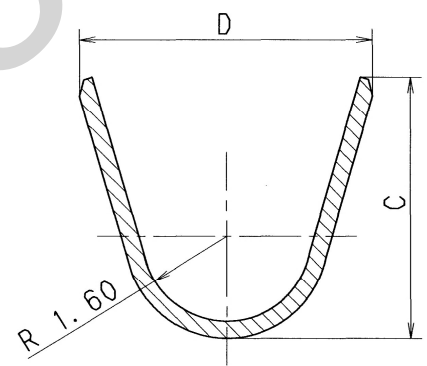

SEC. G-G (10/1)

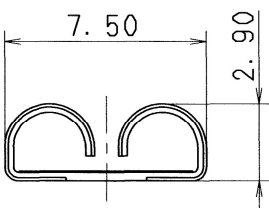

| |
|------------|
| ISSUE MARK |
|------------|

| | | | | | | | | | | | | | | |
|-------------------|-----------------------------------|---------------------|--------|-------------------|------------|----------|--------|---------------------------------|-------------|--------------------|----------|-------|-----------------------|---------------------------|
| △ 08.04.24 | CHANGED WIRE SIZE | C08-Z290 | T. S | CUSTOMER | | | | MATL. SPEC. | SEE TABLE | TREAT. & FIN. | | | | |
| △ 97.06.05 | CHANGED FORM & ELIMINATE PART NO. | C97-M053 | M. Y | CUSTOMER PART NO. | | | | CUSTOMER DWG NO. | | | | | | |
| △ 93.03.12 | ADDED PART NO. | C93-6324 | I. I | OFFICE | | | | TRIAL PART NO. | | | | | | |
| 88.10.18 | NEW | 8MC-3238 | T. M | VENDOR | | | | NAME △ CONNECTOR LOCKING FINGER | | | | | | |
| LET | DATE | REVISION RECORD NO. | CHKD | VENDOR NO. | | | | TYPE 250 TERMINAL FEMALE | | | | | | |
| GENERAL TOLERANCE | | | | DWG TYPE | DWG SOURCE | DWG DATE | UNIT | SCL | ANGLE | PART NO. | | | | |
| | 10MAX | 50MAX | 100MAX | 250MAX | 2500VR | ANGLE | ECCENT | R | NEW | 88.10.13 | mm | 5/1 | 3 | PART NO. △ 7116-2641 ETC. |
| A | ±0.15 | ±0.2 | ±0.3 | ±0.5 | ±0.75 | ±30' | 0.1 | APPROVED | CHECKED | CHECKED | DESIGN | DRAWN | DWG NO. △ 7116-2641:R | SET DWG NO. |
| B | ±0.2 | ±0.3 | ±0.55 | ±0.95 | ±1.4 | ±30' | 0.1 | TAKENOUCHI | J. GALLARES | YAZAKI CORPORATION | | | | |
| © | ±0.3 | ±0.5 | ±0.8 | ±1.4 | ±2 | ±30' | 0.15 | 08.04.25 | | 82.06.23 | 08.04.24 | | | |
| SPECIFIED | | | | MASS | | | | | | | | | | |
| | | | | g | | | | | | | | | | |

1

2

3

