

NO.	PART NO. AND CH. CODE	PART NAME	MATERIAL & SPEC.
①	△ 7116-1456	△ BODY FOR YV-TYPE TERMINAL (F)	BRASS (TIN PLATING)
②	7157-8606	△ SPRING FOR YV-TYPE TERMINAL (F)	△ BERYLLIUM COPPER (TIN PLATING)

注記

- △ 1. 適用電線サイズ : CAVS 0.3~0.5
- 2. かん合オスターミナル品番 : 7114-1456
- 3. 適用ハウジング品番 : 7123-7735, 7123-7736-90

△ NOTES

- △ 1. APPLICABLE WIRE SIZE : CAVS 0.3~0.5
- 2. MATING MALE TERMINAL PART NO. : 7114-1456
- 3. APPLICABLE HOUSING PART NO. : 7123-7735, 7123-7736-90

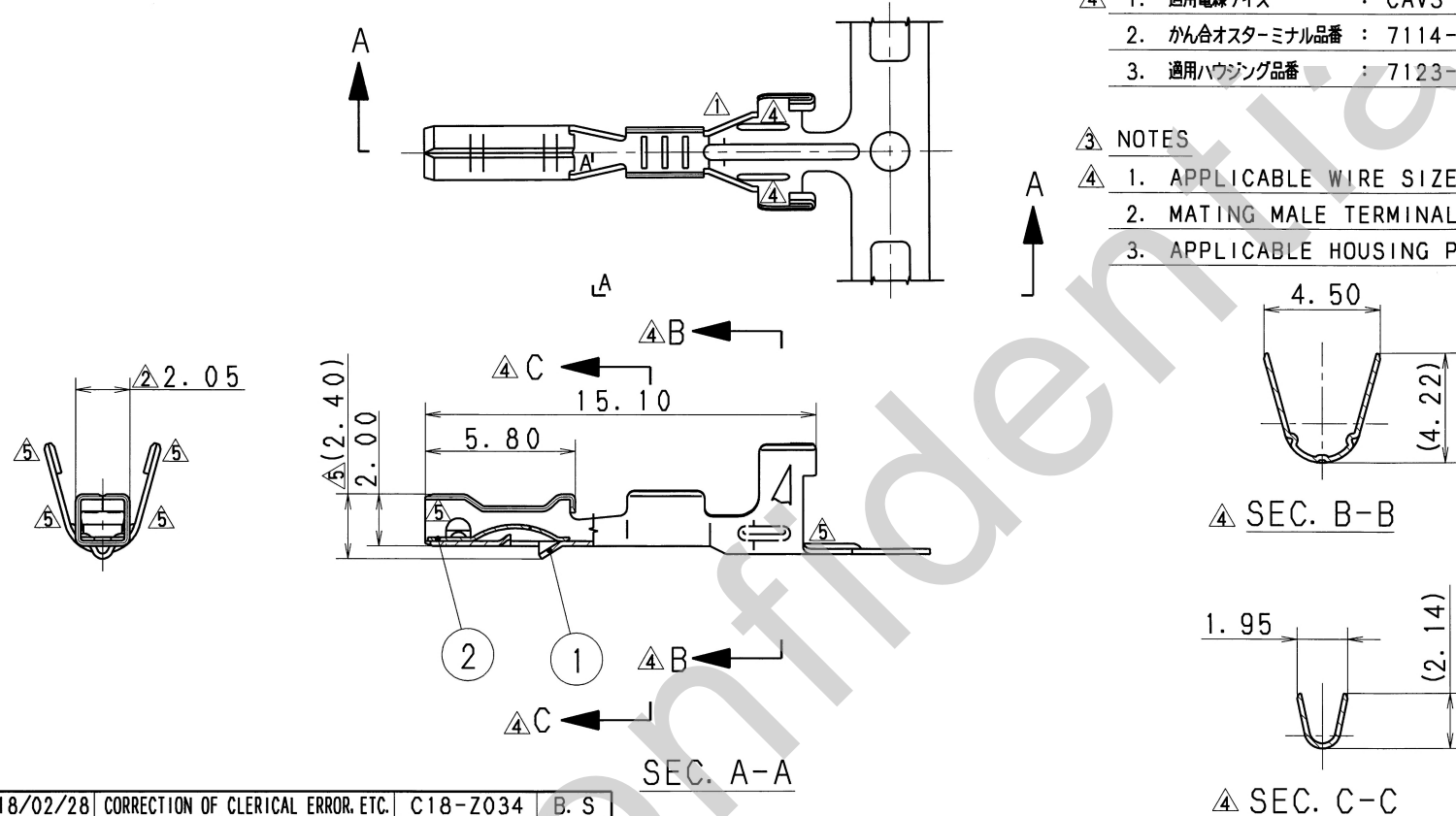

△	2018/02/28	CORRECTION OF CLERICAL ERROR ETC.	C18-Z034	B. S									
△	2004/11/17	CHANGED WIRE SIZE ETC.	C04-ZE15	T. M									
△	1997/03/04	ADDED GENERAL TOLERANCE ETC.	C97-L469	M. H									
△	1989/03/28	CHANGED DIMENSION	C89-6485	永野									
△	1989/03/09	CHANGED FORM	C89-6371	永野									
	1987/06/02	NEW	7MC-0258	児玉									
LET	DATE	REVISION RECORD	NO.	CHKD									
GENERAL TOLERANCE													
	10MAX	50MAX	100MAX	250MAX	2500VR	ANGLE	ECCENT	DWG TYPE	DWG SOURCE	DWG DATE	UNIT	SCL	ANGLE
A	±0.15	±0.2	±0.3	±0.5	±0.75	±30'	0.1	R	NEW	1987/06/02	mm	5:1	3
B	±0.2	±0.3	±0.55	±0.95	±1.4	±30'	0.1	APPROVED	CHECKED	CHECKED	DESIGN	DRAWN	
△	±0.3	±0.5	±0.8	±1.4	±2	±30'	0.15	M. NAKAMURA			OHTAKA	B. SISON	
SPECIFIED							MASS	g	2018/02/28		1987/06/02	2018/02/28	

CUSTOMER				MATERIAL SPEC.				SEE TABLE		TREAT. & FIN.	
CUSTOMER PART NO.				CUSTOMER DWG NO.				NAME			
OFFICE				TRIAL PART NO.				△ YV-TYPE TERMINAL (F)			
VENDOR								ISSUE MARK			
VENDOR NO.											
PART NO.				7116-1456							
CH. CODE											
DWG NO.				7116-1456:R				SET DWG NO.			
YAZAKI CORPORATION											