

PART NO.	W ₁	W ₂	MATERIAL	APPLICABLE WIRE SIZE
7114-2873	3.1	6.2	C 2680 t=0.4	(AVS) AV 0.5 ~ 1.25
7114-2874	4.3	8.1		(AVS) AV 2 ~ 3
⚠ 7114-2873-02	3.1	6.2	C 2680 t=0.4 TIN PLATING	(AVS) AV 0.5 ~ 1.25
⚠ 7114-2874-02	4.3	8.1		(AVS) AV 2 ~ 3

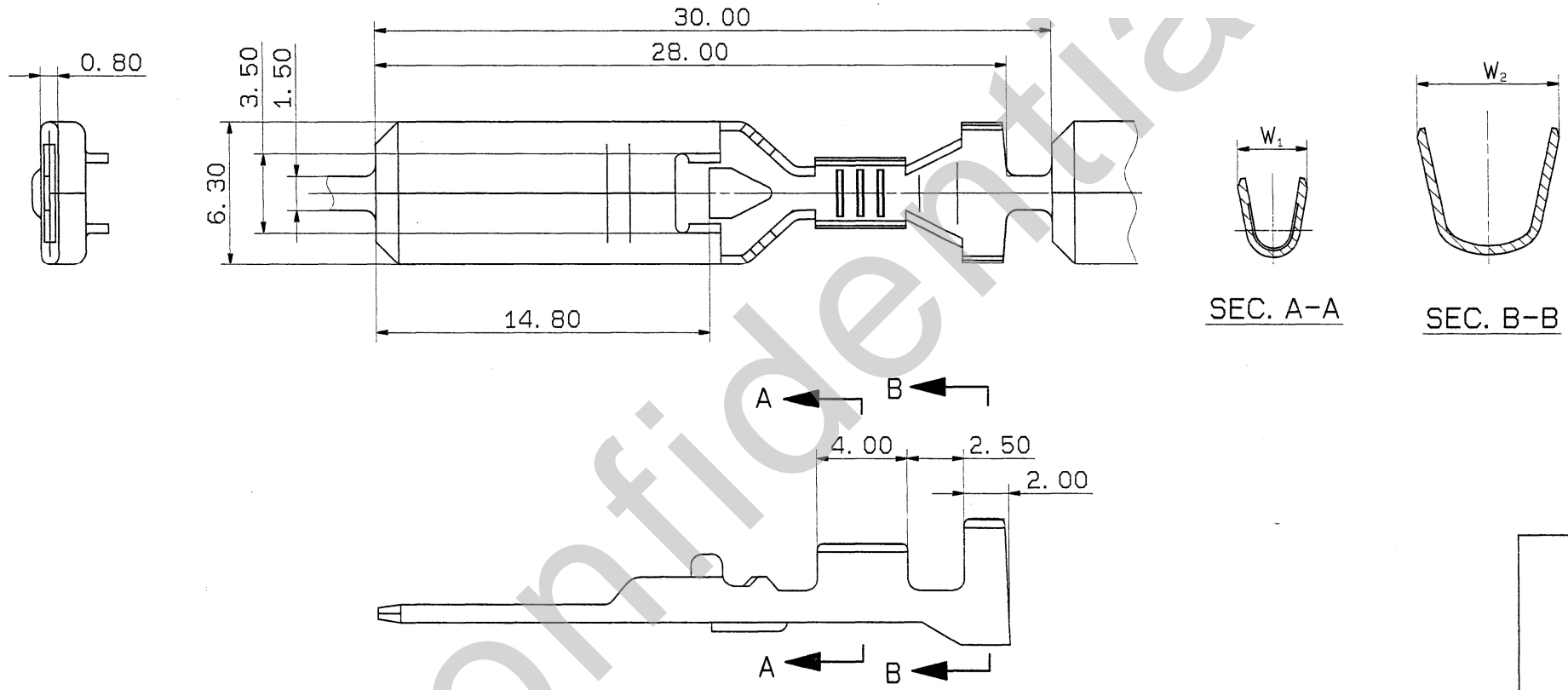

ISSUE MARK

CUSTOMER										MATL. SPEC.		TREAT. & FIN.		
CUSTOMER PART NO.					CUSTOMER DWG NO.					SEE TABLE				
⚠	91.12.10	RENEW	C91-L879	K. S	OFFICE	TRIAL PART NO.					NAME ⚠ X TYPE TERMINAL M			
LET	DATE	REVISION RECORD	NO.	CHKD	VENDOR									
GENERAL TOLERANCE					VENDOR NO.									
	10MAX	50MAX	100MAX	250MAX	250OVR	ANGLE	ECCENT	DWG TYPE	DWG SOURCE	DWG DATE	UNIT	SCL	ANGLE	PART NO.
A	±0.15	±0.2	±0.3	±0.5	±0.75	±30'	0.1	R	RENEW	91.12.10	mm	5/1	3	7114-2873 ETC.
B	±0.2	±0.3	±0.55	±0.95	±1.4	±30'	0.1	APPROVED	CHECKED	CHECKED	DESIGN	DRAWN		DWG NO.
©	±0.3	±0.5	±0.8	±1.4	±2	±30'	0.15	MAKITA		ISHIZUKA		7114-2873:R		
SPECIFIED					MASS					YAZAKI CORPORATION				
					g									