

YAZAKI PART NO.	APPLICABLE WIRE SIZE	H ₁	H ₂	W ₁	W ₂	MATL.&SPEC.
7114-1300 (7B14-1300)	AVS, CAVS 0.2~0.3sq	2.2	3.1	2.1	2.9	黄銅Snメッキ (t=0.30)
7114-1301 (7B14-1301)	AVS, CAVS 0.5~0.85sq	2.8	3.9	2.5	3.0	黄銅Snメッキ (t=0.30)
7114-1300-08	AVS, CAV 0.2~0.3sq	2.2	3.1	2.1	2.9	黄銅Auメッキ (t=0.30)
7114-1301-08	AVS, CAV 0.5~0.85sq	2.8	3.9	2.5	3.0	黄銅Auメッキ (t=0.30)
7114-1302	0.15sq専用	1.69	2.2	2.1	2.4	黄銅Snメッキ (t=0.30)

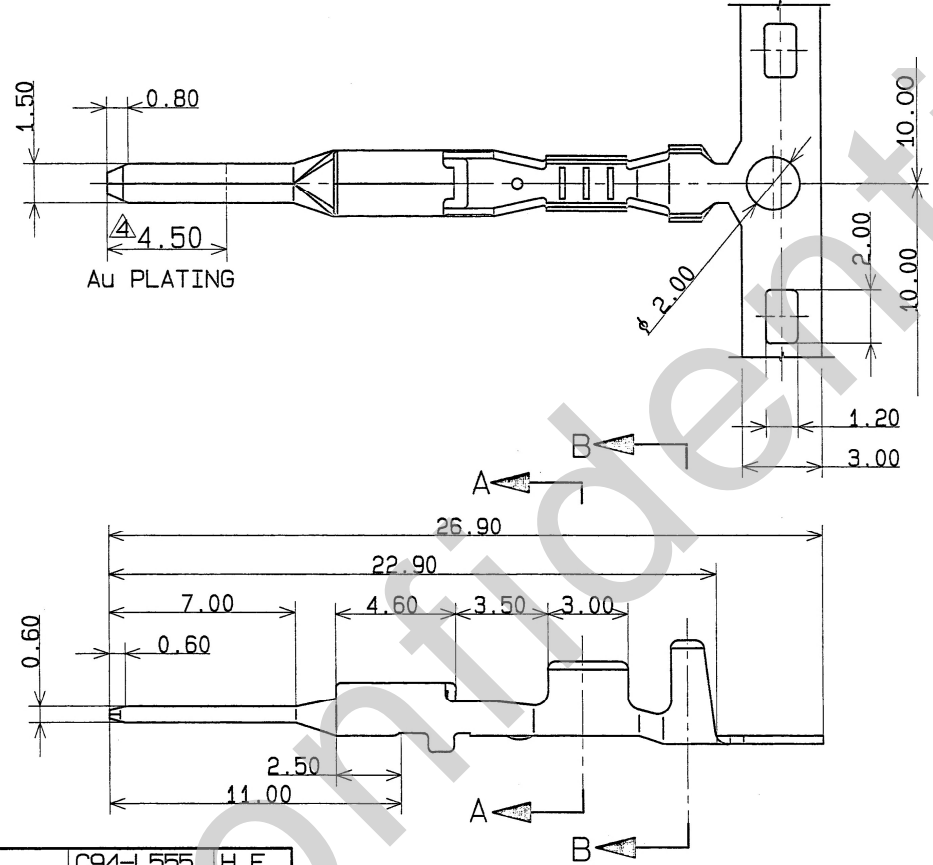
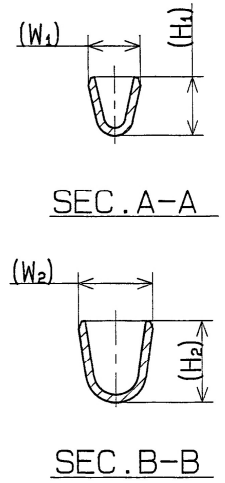

注記
 1) 嵌合相手品番 : 7116-1300 ETC.
 2) 適用ハウジング品番 : 7122-7960 ETC.
 3) () 内品番は、エアバッグ回路及び特別管理回路を使用する時に適用すること。

NOTES
 1) MATING PART NO. : 7116-1300 ETC.
 2) APPLICABLE HOUSING PART NO.: 7122-7960 ETC.
 3) () PART NO. TO BE USED AIR-BAG SYSTEM AND ADMINISTRATION SYSTEM.

△	94.04.18	CORRECTED ERROR	C94-L555	H.F
△	93.10.19	ADDED PART NO. ETC.	C93-P164	K.S
△	89.07.12	CHANGED COMPOSITION	C89-7104	H.I
△	89.05.17	CORRECTED ERROR	C89-6820	T.N
△	88.12.08	ADDED PART NO., NOTE	8MC-1540	T.N
△	87.11.16	NEW	7MC-0774	K.A
LET	DATE	REVISION RECORD	NO.	CHKD

CUSTOMER	CUSTOMER PART NO.	CUSTOMER DWG NO.
OFFICE	TRIAL PART NO.	
VENDOR	VENDOR NO.	

MATL. SPEC.	SEE TABLE	TREAT. & FIN.
NAME	C-TYPE TERMINAL (M)	

GENERAL TOLERANCE							VENDOR NO.							
	10MAX	50MAX	100MAX	250MAX	2500VR	ANGLE	ECCENT	DWG TYPE	DWG SOURCE	DWG DATE	UNIT	SCL	ANGLE	
A	±0.15	±0.2	±0.3	±0.5	±0.75	±30'	0.1	R	NEW	87.11.16	mm	5/1	3	
B	±0.2	±0.3	±0.55	±0.95	±1.4	±30'	0.1	APPROVED	CHECKED	CHECKED	DESIGN	DRAWN		
◎	±0.3	±0.5	±0.8	±1.4	±2	±30'	0.15				K.ABE	SAMUKAWA		
SPECIFIED							MASS							

PART NO. CH.CODE	7114-1300 ETC.
DWG NO.	7114-1300: R
YAZAKI CORPORATION	