

SUB ASSEMBLY PART NUMBER	NO.	PART NUMBER	PART NAME	MATERIAL	COLOR	QUANTITY
7283-6445-40	①	7183-6445-40	2P 2.8mm YESC KAIZEN UNSEALED FEMALE HOUSING	PBT+GF	LIGHT GRAY	1
	②	7158-5972-50	2P 2.8mm YESC KAIZEN UNSEALED FEMALE TPA	PBT	ORANGE	1

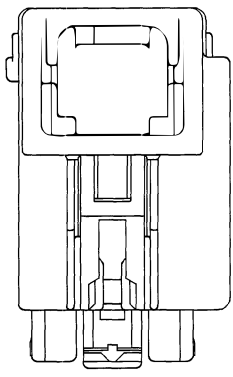

(1/1)

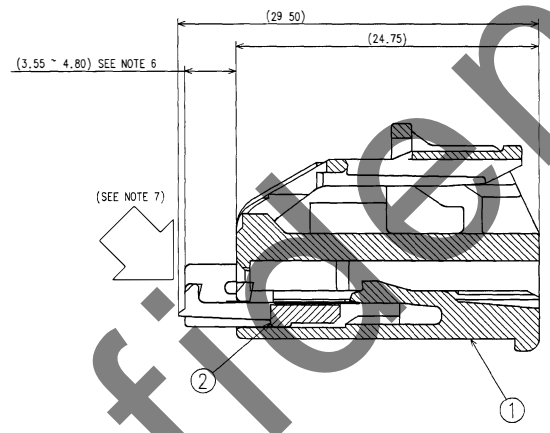
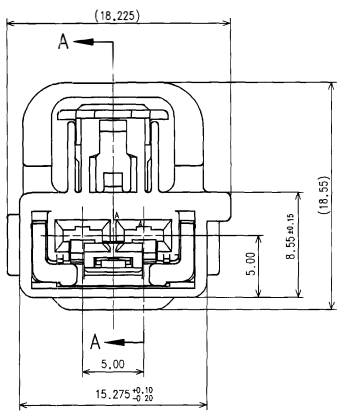

SECTION A-A

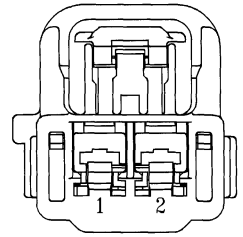

- NOTES.
- PARTS MUST BE PURCHASED FROM YAZAKI.
 - PARTS MUST BE FREE OF FLASH AND IMPERFECTIONS THAT AFFECT FUNCTION.
 - APPLICABLE TERMINAL NUMBER. SEE 7116-4270-02 R DRAWING. (2.8mm YESC KAIZEN) SEE 7116-4110-02 R DRAWING. (2.8mm YESC)
 - MATING PART NUMBER. 7282-6445-40
 - PART DESIGNED TO SATISFY USCAR-2, REVISION 3, DATED APRIL 2001, CLASS 2.
 - THIS DIMENSION SHOWS THE PRE-SET POSITION OF THE TPA.
 - PROPER LOCK AND RELEASE FOR TPA MUST BE CARRIED OUT WHILE PUSHING FINAL LOCK ARM IN THE ARROW DIRECTION.
 - THIS DRAWING IS TO BE USED FOR INTERNAL YAZAKI PSW SUBMISSION.

ISSUE MARK

CUSTOMER	CUSTOMER PART NO.	CUSTOMER DWG NO.	MATL. SPEC.	SEE TABLE	TREAT. & FIN.
OFFICE	YNA	TRIAL PART NO.	NAME	2P 2.8 YESC KAIZEN UNSEALED	
VENDOR	VENDOR NO.		FEMALE SUB ASSEMBLY		
GENERAL TOLERANCE			PART NO. 7283-6445-40		
DWG TYPE: R			DWG NO. 7283-6445-40:R		
DWG SOURCE: M			DWG DATE: 11.17.05		
APPROVED: [Signature]			DESIGN: [Signature]		
CHECKED: [Signature]			DRAWN: [Signature]		
JEN VUN NO. [Signature]			DATE: 07.11.02		
WEIGHT: 8			YAZAKI CORPORATION		

LET	DATE	REVISION RECORD	NO.	CHKD
	11.17.05	NEW	CDS-AD60	U.O.