

SUB ASS' Y NO. & C. C.	NO.	PART NO.	MATERIAL	COLOR	QTY.
7283-5569-40	①	7183-5569-40	HPA	LIGHT GRAY	1
	②	7158-4204-50	HPA	ORANGE	1

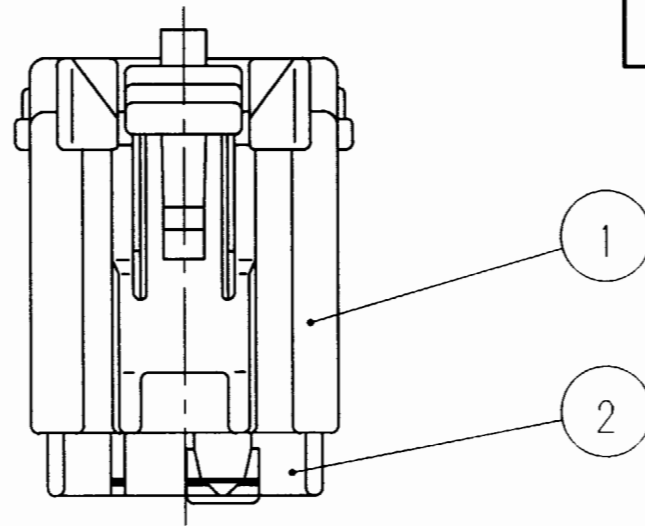

注記

- 1. 適用端子品番 : 7116-4110-02 ETC.
- 2. 嵌合相手品番 : 7282-5569-40

NOTES

- 1. APPLICABLE TERMINAL PART NO. : 7116-4110-02 ETC.
- 2. MATING PART NO. : 7282-5569-40

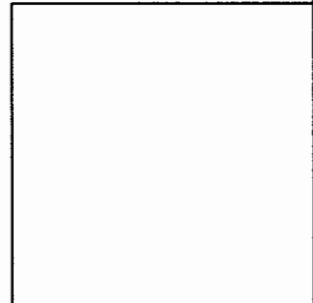
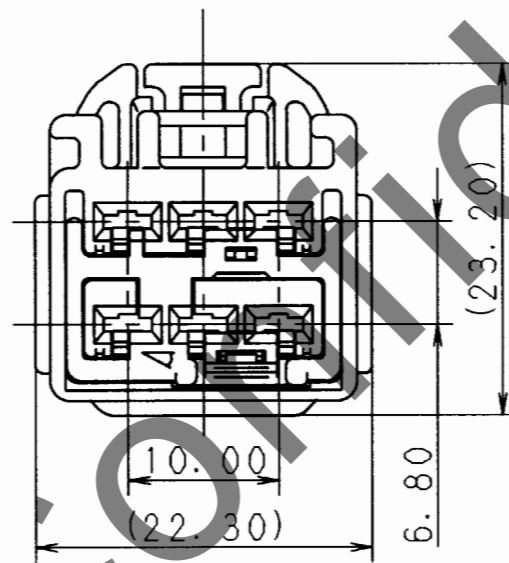
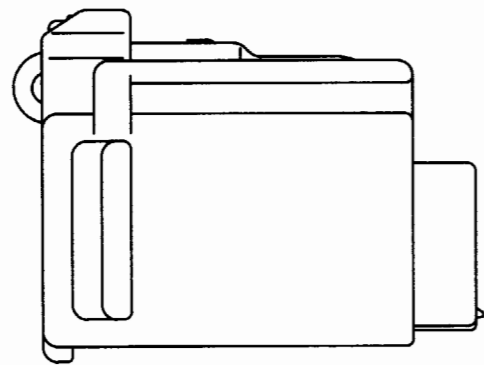

ISSUE MARK

				CUSTOMER				MATL. SPEC. SEE TABLE				TREAT. & FIN.													
				CUSTOMER PART NO.				CUSTOMER DWG NO.																	
97.04.18				NEW				C97-L643				H. K													
LET DATE				REVISION RECORD				NO.				CHKD													
								OFFICE				TRIAL PART NO.													
								VENDOR																	
								VENDOR NO.																	
GENERAL TOLERANCE								DWG TYPE		DWG SOURCE		DWG DATE		UNIT		SCL		ANGLE							
10MAX		50MAX		100MAX		250MAX		250OVR		ANGLE		ECCENT		R		NEW		97.04.18		mm		2/1		3	
A ±0.15		±0.2		±0.3		±0.5		±0.75		±30'		0.1		APPROVED		CHECKED		CHECKED		DESIGN		DRAWN		PART NO. 7283-5569-40	
B ±0.2		±0.3		±0.55		±0.95		±1.4		±30'		0.1		T. SUZUKI		SATOH								CH. CODE 7283-5569-40:R	
C ±0.3		±0.5		±0.8		±1.4		±2		±30'		0.15		SATOH		SATOH								SET DWG NO.	
SPECIFIED								MASS		9		97.04.25		97.04.25		97.04.22		97.03.24		97.04.18		YAZAKI CORPORATION			